

NRW[®]
DRIVE TECHNOLOGIES

A/F SERIE

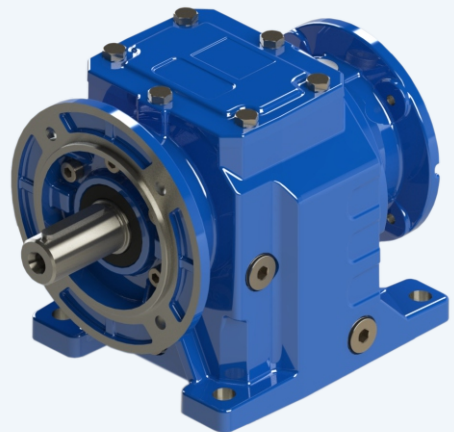

Stirnradtriebmotoren
Helical Geared Motors
Motoriduttori Coassiali
Motoréducteurs Coaxiaux
Motorreductores Coaxiales

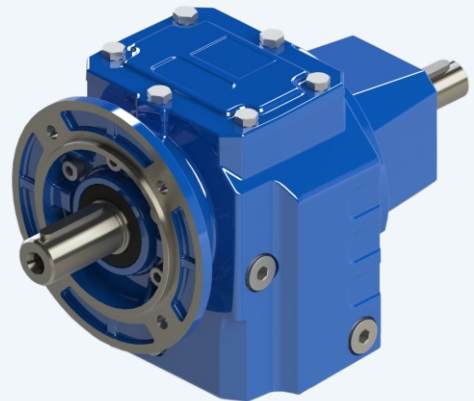
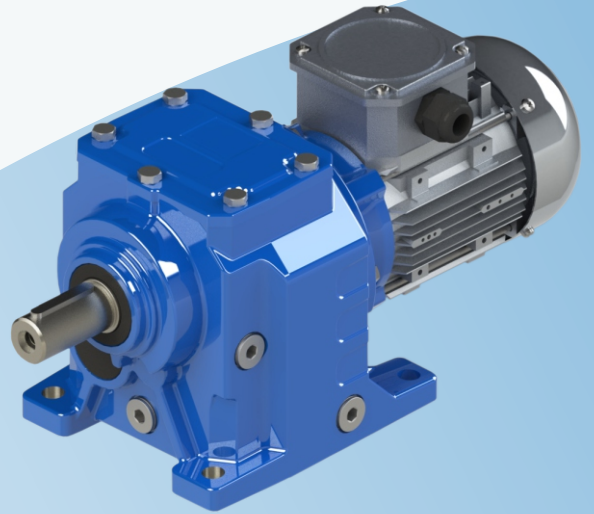

Eine Änderung in diesem Katalog der Technischen Werte sowie Daten und Maßen und Gewichte bleiben vorbehalten

We reserve the right to without previous notice for changing or fully change-over or cancelling which information is specified at catalogue

NRW[®]
DRIVE TECHNOLOGIES

INHALT / CONTENTS / INDICE / INDEX / INDICE

Zeichen / Symbols / Simbologia / Symboles / Simbologia	3
Technische Informationen / Technical Information / Informazioni Tecniche / Informacion Tecnica / Información Técnico	4 - 7
Betriebsfaktor / Service factor / Fattore di servizio / Facteur de service / Factor de servicio	8 - 9
Kritische Anwendungen / Critical applications / Applicazioni critiche / Applications critiques / Aplicaciones Críticas	10 - 11
Thermische Leistung / Thermal Power / Potenza termica / Puissance thermique / Potencia térmica	12 - 15
Montage des Motors an den PAM - Flansch B5 / Motor mounting with PAM flange B5 / Montaggio motore su flange B5 / Installation moteur sur bride PAM B5 / Montaje de motores con brida B5	16
Elastische Kupplung / Flexible Joint / Giunto Elastico / Accoupl. Élastique / Acopl. Elástico	17
Montage / Installation / Installazione / Installation / Instalación	18 - 19
Querbelastrungen / Radial loads / Carichi radiali / Charges radiales / Cargas radiales	20 - 23
Massenträgheitsmomente / Moments of inertia / Momenti d'inerzia / Moments d'inertie / Momentos de inercia	24
Schmierung / Lubrication / Lubrificazione / Lubrification / Lubricación	25 - 27
Einbaulage / Mounting positions / Piazzamento / Pos. de montage / Pos. de montaje	28- 30
Modulares Baukastensystem / Modularity / Modularità / Modularité / Modularidad	31
Produkte / Products / Prodotti / Produits / Productos	32
Beispiel Bestellbeschreibung / Example for ordering / Esempio di ordinazione / Exemple de commande / Ejemplo orden de compra	33
Bezeichnung / Designation / Designazione / Désignation / Designación	34
Nomenklatur / Nomenclature / I termini usati / Les termes utilisés / Los términos utilizados	35
Zubehör / Accessories / Accessori / Accessoires / Accesorios	36
Auswahltablelle von Getriebemotoren / Selection Tables of Gearedmotors / Tabella di selezione di motoriduttori / Tableau de sélection du motoreducteurs / Tabla de selección de motorreductores	39 - 107
Maßtabellen / Dimension Tables / Dimensione Tabelle / Tables de Dimension / Tablas de Dimensiones	109 - 141
Auswahltablelle von W - PAM - IEC Adaptern / Selection Tables of W - IEC and PAM Adapters / Tabella di selezione di W - PAM - IEC Adattatore / Tableau de sélection du W - PAM - IEC Adaptateur / Tabla de selección de W - PAM - IEC Adaptador	143 - 154
Allgemeine Stockliste / General Part List / Generale Elenco Delle Parti / Générale la liste des pièces / Lista de Piezas en General	156 - 166
Elektromotoren / Electric Motors / Motori elettrici / Moteurs électriques / Motores eléctricos	168 - 188
Motor Teileliste / Motor parts list / Parti motore list / Pièces de moteur liste / Piezas del motor lista	189 - 192
Bremse Teileliste / Brake parts list / Elenco delle parti freno / Liste des pièces de frein / Lista de piezas de freno	193



A series of horizontal dotted lines spanning the width of the page, intended for writing or drawing.

DE ZEICHEN

EN SYMBOLS

IT SIMBOLOGIA

FR SYMBOLES

ES SIMBOLOGÍA

Zeichen

P = Leistung in	(kW)	1 = Antriebswelle
M = Drehmoment in	(Nm)	2 = Abtriebswelle
n = Drehzahl in	(rpm)	R = Radial
i = Übersetzung		A = Axial
F = Kraft in	(N)	s = Statisch
m = Masse in	(kg)	d = Dynamisch
f_B = Betriebsfaktor		max = Maximal
		min = Minimal

Symbols

P = Power	(kW)	1 = Input shaft
M = Torque	(Nm)	2 = Output shaft
n = Speed	(rpm)	R = Radial
i = Reduction ratio		A = Axial
F = Load	(N)	s = Static
m = Weight	(kg)	d = Dynamic
f_B = Service factor		max = Maximum
		min = Minimum

Simbologia

P = Potenza	(kW)	1 = Albero ingresso
M = Momento torcente	(Nm)	2 = Albero uscita
n = Numero giri	(giri / 1')	R = Radiale
i = Rapporto di riduzione		A = Assiale
F = Forza	(N)	s = Statico
m = Peso	(kg)	d = Dinamico
f_B = Fattore di servizio		max = Massimo
		min = Minimo

Symboles

P = Puissance	(kW)	1 = Arbre d'entrée
M = Moment de torsion	(Nm)	2 = Arbre de sortie
n = Nombre de tours	(tours/min)	R = Radial
i = Rapport de réduction		A = Axial
F = Force	(N)	s = Statique
m = Poids	(kg)	d = Dynamique
f_B = Facteur de service		max = Maximum
		min = Minimum

Simbologia

P = Potencia	(kW)	1 = Eje de entrada
M = Momento torsor	(Nm)	2 = Eje de salida
n = Número de revoluciones	(rpm)	R = Radial
i = Relación de reducción		A = Axial
F = Fuerza	(N)	s = Estático
m = Peso	(kg)	d = Dinámico
f_B = Factor de servicio		max = Máximo
		min = Mínimo

DE TECHNISCHE INFORMATIONEN

Für die korrekte Auswahl eines Getriebes oder eines Getriebemotors müssen einige grundsätzliche Daten bekannt sein.

A. Die Antriebsdrehzahl am Getriebeeingang (n1) und die gewünschte Abtriebsdrehzahl (n2).
Mit diesen beiden Werten kann das Übersetzungsverhältnis (i) des Getriebes mit der folgenden Formel ausgerechnet werden:

$$i = \frac{n1}{n2}$$

B. Das für die Anwendung erforderte Drehmoment (MH)
Wenn diese Daten bekannt sind, kann mit der Auswahl des Getriebemotors oder des Getriebes fortgefahren werden.

Auswahl der Getriebe

Dieser Ratgeber führt in wenigen Schritten durch die Auswahl des geeigneten Getriebes:

1. Den Betriebsfaktor (fb) der Anwendung bestimmen. Dieser Parameter ist eine Funktion aus der Belastungsart der angetriebenen Maschine, der Anzahl der Anläufe pro Stunde und der Betriebsstundenzahl (siehe Absatz "Betriebsfaktor" S.8)
2. Die Eingangsleistung PH über das erforderliche Drehmoment MH, die Abtriebsdrehzahl n2 und den dynamischen Wirkungsgrads ermitteln.
Der Wert des dynamischen Wirkungsgrads hängt von der Art des Getriebes und von der Anzahl der Übersetzungsstufen ab. Für die Stirnradgetriebe der Serie A/F gilt ein mittlerer Wert von 0,9 (ηd)
A/F..1 Übersetzungsstufen = 0,97
A/F..2 Übersetzungsstufen = 0,96
A/F..3 Übersetzungsstufen = 0,94

$$PH = \frac{MH \cdot n2}{9550 \cdot \eta d}$$

3. Eine genormte Leistung P1 aus der Tabelle der Getriebemotorenleistungen aussuchen, die höher ist als die erforderliche PH, sodass:

$$P1 \geq PH$$

4. Nach dem Ermitteln der geeigneten genormten Leistung den Getriebemotor auswählen, der die Abtriebsdrehzahl zur Verfügung stellt, die der gewünschten n2 am nächsten kommt und der einen gleich hohen oder größeren Betriebsfaktor fb besitzt als durch die Anwendung gefordert.

In den Auswahltabellen der Getriebemotoren sind die Kombinationen mit 50Hz - Motoren mit 4 oder 6 Polen dargestellt. Für abweichende Antriebsgeschwindigkeiten berücksichtigen Sie bitte die Daten aus den Getriebe tabellen.

EN TECHNICAL INFORMATION

For correctly selecting a gear reducer or geared motor, several essential pieces of data are required:

A. The rotational input speed to the gear reducer (n1) and the rotational output speed (n2).
Through these two values it is possible to calculate the reduction ratio (i) of the gear reducer using the following formula:

$$i = \frac{n1}{n2}$$

B. The torque required by the application (MH) The geared motor or gear reducer can be once this data is known.

Geared motor selection

This guide indicates a brief sequence of steps for selecting a suitable product:

1. Determine the application's actual service factor (fb) This parameter depends on the type of load of the powered machine, the number of starts per hour and the hours of operation (refer to the "Service factor" paragraph on page 8)
2. Calculate the input power PH using the required torque value MH, the speed n2 and dynamic efficiency value. The dynamic efficiency value depends on the type of gear reducer and on the number of gear reduction stages. A/F-range helical gear reducers have an average value equal to: (ηd)
A/F..1 stages = 0,97
A/F..2 stages = 0,96
A/F..3 stages = 0,94

$$PH = \frac{MH \cdot n2}{9550 \cdot \eta d}$$

3. Consult the geared motor performance tables and identify a normalised power value P1 exceeding the required power PH, such that:

$$P1 \geq PH$$

4. Once the suitable normalised power has been identified, select the geared motor capable of generating the rotational speed closest to the desired n2 value and with service factor fb greater or equal to that required by the application.

In the geared motor selection tables the combinations include 4-pole and 6-pole motors powered at 50Hz; for different drive speeds refer to the nominal data provided for the gear reducers.

IT INFORMAZIONI TECNICHE

Per la corretta selezione di un riduttore o di un motoriduttore occorre disporre de alcuni dati fondamentali quali:

A. La velocità angolare in entrata al riduttore (n1) e la velocità angolare in uscita (n2).
Attraverso questi due valori é possibile calcolare il rapporto di riduzione (i) del riduttore attraverso la formula:

$$i = \frac{n1}{n2}$$

B. Il momento torcente richiesto dall' applicazione (MH).
Noti questi dati, si può procedere nella selezione del motoriduttore o del riduttore.

Selezione dei motoriduttori

Questa guida conduce alla selezione del prodotto attraverso pochi passi:

1. Determinare il fattore di servizio effettivo dell'applicazione (fb). Questo parametro é funzione del tipo di carico della macchina azionata, del numero di azionamenti per ora e del numero di ore di funzionamento (vedi paragrafo "Fattore di servizio" pag. 9).
2. Ricavare la potenza in entrata PH mediante il momento torcente richiesto MH, la velocità n2 e il rendimento dinamico.
Il valore di rendimento dinamico dipende dalla tipologia del riduttore e dal numero di stadi d'ingranaggi di riduzione. I riduttori coassiali della serie A/F presentano un valore medio pari a:(ηd)
A/F..1 stadi = 0,97
A/F..2 stadi = 0,96
A/F..3 stadi = 0,94

$$PH = \frac{MH \cdot n2}{9550 \cdot \eta d}$$

3. Consultare le tabelle delle prestazioni dei motoriduttori ricercando una potenza normalizzata P1 superiore a quella richiesta PH tale che:

$$P1 \geq PH$$

4. Individuata la potenza normalizzata idonea, selezionare dunque il motoriduttore in grado di sviluppare la velocità angolare più vicina a quella n2 desiderata e con fattore di servizio fb. maggiore o uguale richiesto dall' applicazione.

Nelle tabelle di selezione dei motoriduttori gli abbinamenti sono realizzati con motori 4,6 poli alimentati a 50Hz, per velocità di azionamento diverse riferirsi ai dati nominali forniti per i riduttori.

FR

INFORMACION TECNICA

Pour choisir correctement un réducteur ou un motoréducteur, il est nécessaire de disposer de certaines données fondamentales telles que:

A. La vitesse angulaire en entrée du réducteur (n1) et la vitesse angulaire en sortie (n2).

Grâce à ces deux valeurs, il est possible de calculer le rapport de réduction (i) du réducteur en utilisant la formule:

$$i = \frac{n1}{n2}$$

B. Le moment de torsion requis par l'application (MH).

Une fois ces données, il est possible de procéder au choix du motoréducteur ou du réducteur.

Selection des motoréducteur

Ce guide permet de procéder à la sélection du produit en suivant quelques étapes:

1. Déterminer le facteur de service effectif de l'application (fb). Ce paramètre dépend du nombre d'actionnements par heure et du nombre d'heures de fonctionnement (voir paragraphe "Facteur de service" page 9).

2. Déterminer la puissance en entrée PH à l'aide du moment de tension requis MH de la vitesse n2 et du rendement dynamique.

La valeur du rendement dynamique dépend du type de réducteur et du nombre de trains d'engrenages de réduction. Les réducteurs coaxiaux de la série A/F présentent une valeur moyenne égale à: (ηd)

A/F..1 trains = 0,97

A/F..2 trains = 0,96

A/F..3 trains = 0,94

$$PH = \frac{MH \cdot n2}{9550 \cdot \eta d}$$

3. Consulter le tableau des performances des motoréducteurs en recherchant une puissance normalisée P1 supérieure à la puissance PH demandée telle que:

$$P1 \geq PH$$

4. Une fois identifiée la puissance normalisée adéquate, sélectionner le motoréducteur en mesure de développer la vitesse angulaire la plus proche de la vitesse n2 désirée et présentant un facteur de service fb. supérieur ou égal à celui demandé par l'application.

Dans les tableaux de sélection des motoréducteurs, les combinaisons sont réalisées avec des moteurs 4,6 pôles alimentés à 50Hz. Pour des vitesses d'actionnement différentes, se référer aux données nominales fournis par les réducteurs

ES

INFORMACIÓN TÉCNICO

Para la correcta selección de un reductor o de un motorreductor es necesario disponer de algunos datos fundamentales como:

A. La velocidad angular a la entrada del reductor (n1) y la velocidad angular a la salida (n2). A través de reducción (i) del reductor utilizando la fórmula:

$$i = \frac{n1}{n2}$$

B. El momento de torsión requerido por la aplicación (MH).

Conocidos estos datos, se puede proceder a la selección del motorreductor o del reductor.

Selección de los motorreductores

Esta guía conduce a la selección del producto a través de unos pocos pasos:

1. Determinar el factor de servicio efectivo de la aplicación (fb). Este parámetro es función del tipo de carga de la máquina accionada, del número de accionamientos por hora y de la cantidad de horas de funcionamiento (ver el párrafo "Factor de servicio" pág. 9)

2. Obtener la potencia a la entrada PH utilizando el momento de torsión requerido MH, la velocidad n2 el rendimiento dinámico.

El valor del rendimiento dinámico depende del tipo de reductor y del número de etapas de engranajes de reducción. Los reductores coaxiales de la serie A/F presentan un valor medio igual a:

A/F..1 trenes = 0,97

A/F..2 trenes = 0,96

A/F..3 trenes = 0,94

$$PH = \frac{MH \cdot n2}{9550 \cdot \eta d}$$

3. Consultar las tablas de las prestaciones de los motorreductores buscando una potencia normalizada P1 superior a la requerida PH tal que:

$$P1 \geq PH$$

4. Una vez identificada la potencia normalizada adecuada, seleccionar el motorreductor capaz de desarrollar la velocidad angular más cercana a la n2 deseada y con un factor de servicio fb mayor o igual que el necesario para la aplicación

En las tablas de selección de los motorreductores, las combinaciones se realizan con motores de 4,6 polos alimentados con 50Hz. Para velocidades de accionamiento diferentes, consultar los datos nominales suministrados para los reductores.

DE TECHNISCHE INFORMATIONEN

Auswahl der Getriebe

1. Den Betriebsfaktor (fb) der Anwendung bestimmen (siehe Absatz "Betriebsfaktor" S.8).
2. Das benötigte Übersetzungsverhältnis i aus der erforderlichen Abtriebsdrehzahl n2 und der Antriebsdrehzahl n1 bestimmen.

$$i = \frac{n1}{n2}$$

3. Das Drehmoment MG für die Auswahl des Getriebes über das von der Anwendung erforderliche Drehmoment MH und den Betriebsfaktor fb ermitteln:

$$MG = MH \cdot (fb)$$

4. Das Getriebe mit dem Übersetzungsverhältnis aus der Tabelle der Getriebedaten auswählen, das dem bestimmten Übersetzungsverhältnis am nächsten kommt und über ein ausreichendes Nennmoment M2 verfügt, sodass:

$$M2 \geq MG$$

Überprüfungen

Nach der Auswahl des Getriebes oder des Getriebemotors ist es ratsam die folgenden Überprüfungen durchzuführen:

A. Thermische Leistung

Die thermische Leistung des Getriebes muss gleich oder größer als die installierte mechanische Leistung sein oder als die von der Anwendung gemäß den im Abschnitt enthaltenen Angaben erforderliche Leistung (siehe Abschnitt "thermische Leistung" S.12).

B. Maximales Drehmoment

Grundsätzlich darf das maximale Drehmoment (momentane Spitzenbelastung), das an das Getriebe angewendet werden kann, nicht mehr als 200% des Nennmoments Mamax betragen.

C. Radiale Belastungen

Überprüfen Sie bitte dass die radialen Belastungen auf den Eingangs- und / oder Ausgangswellen die zugelassenen Katalogwerte nicht überschreiten. Wenn diese größer sind, bitte die Getriebegröße anpassen oder die Auslegung für die externe Last anpassen. In der Prüfphase bitte berücksichtigen, dass die im Katalog angegebenen Werte sich auf Lasten beziehen, die auf die Mittelachse des Wellenüberstands wirken. Daher ist es notwendig mit den entsprechenden Formeln die zugelassene Last in der gewünschten Position zu bestimmen. Falls diese in einer davon abweichenden Position angebracht wird, siehe Absatz "Radiale Belastungen S. 20.

EN TECHNICAL INFORMATION

Gear reducer selection

1. Determine the application's service factor (fb) (consult to the "Servico factor" paragraph on page 8).
2. Calculate the reduction ratio i from the requested output speed n2 and from the input speed n1.

$$i = \frac{n1}{n2}$$

3. Calculate the torque MG for selecting the gear reducer through the torque required by the application MH and the service factor s.f.:

$$MG = MH \cdot (fb)$$

4. Consult the gear reducer performance tables and identify the gear reducer that - with a reduction ratio closest to the calculated ratio - has a nominal torque M2 such that

$$M2 \geq MG$$

Checks

Once the gear reducer or geared motor has been selected, the following checks should be performed:

A. Thermal Power

The gear reducer's thermal power must be equal to or greater than the installed mechanical power, or the power required by the application according to the indications contained in the section (refer to the "Thermal power" paragraph on page 12).

B. Maximum Torque

Generally, the maximum torque (peak instantaneous load) that can be applied to the gear reducer must not exceed 200% of the nominal torque Mamax.

C. Radial Loas

Verify that the loads acting on the input and/or output shaft are within with the values indicated in the catalogue. If they exceed these values, increase the size of the gear reducer or modify the external load capacity. During the checking phase, it is important to remember that the values indicated in the catalogue refer to loads acting on the mid-point of the shaft protrusion, therefore, if the load is applied to a different position, appropriate formulas must be used to calculate the admissible load in the desired position (refer to the "Radial loads" paragraph on page 20).

IT INFORMAZIONI TECNICHE

Selezione dei riduttori

1. Determinare il fattore di servizio dell'applicazione (fb) (vedi paragrafo "Fattore di servizio" pag. 9)
2. Calcolare il rapporto di riduzione i dalla velocità in uscita n2 richiesta e dalla quella in entrata n1.

$$i = \frac{n1}{n2}$$

3. Ricavare il momento torcente MG per la selezione del riduttore attraverso la coppia richiesta dall'applicazione MH ed il fattore di servizio f.s.:

$$MG = MH \cdot (fb)$$

4. Consultare le tabelle delle prestazioni dei riduttori cercando il riduttore che, col rapporto di riduzione più prossimo a quello calcolato, dispone di una coppia nominale M2 tale che:

$$M2 \geq MG$$

Verifiche

Esguita la selezione del riduttore o del motoriduttore è opportuno effettuare le seguenti verifiche:

A. Potenza Termica

La potenza termica del riduttore deve essere uguale o maggiore della potenza meccanica installata o della potenza richiesta dall'applicazione secondo le indicazioni contenute nella sezione (vedi paragrafo "Potenza termica" pag 13).

B. Coppia Massima

Generalmente la coppia massima (picco di cario istantaneo) che può essere applicata al riduttore non deve superare il 200% della coppia nominale Mamax.

C. Carichi radiali

Verificare che i carichi radiali agenti sugli alberi di entrata e/o di uscita rispettino i valori ammessi a catalogo. Se superiori, aumentare la grandezza del riduttore o modificare la supportazione del carico esterno. Nella fase di verifica occorre tenere conto che i valori indicati a catalogo si riferiscono a carichi agenti sulla mezziera della sporgenza dell'albero per cui, nel caso il carico sia applicato in posizione deversa è necessario determinare con le apposite formule il carico ammissibile nella posizione desiderata (vedi paragrafo "Carichi Radiali" pag 21).

FR

INFORMACION TECNICA

Sélection des réducteurs

1. Déterminer le facteur de service de l'application (f_b) (voir paragraphe "Facteur de service" page 9).
2. Calculer le rapport de réduction (i) à partir de la vitesse n_2 requise en sortie et de la vitesse en entrée n_1

$$i = \frac{n_1}{n_2}$$

3. Déterminer le moment de torsion MG pour la sélection du réducteur à l'aide du couple MH requis par l'application et du facteur de service f_b :

$$MG = MH \cdot (f_b)$$

4. Consulter les tableaux des performances des réducteurs en recherchant le réducteur disposant du rapport de réduction le plus proche du rapport calculé et présentant un couple nominal M_2 tel que:

$$M_2 \geq MG$$

Vérifications

Une fois sélectionné le réducteur ou le motoréducteur, il convient d'effectuer les vérifications suivantes:

A. Puissance Thermique

La puissance thermique doit être égale ou supérieure à la puissance mécanique installée, ou à la puissance requise par l'application, conformément aux indications contenues dans la section (voir paragraphe "Puissance thermique" page 13).

B. Couple Maximal

Généralement, le couple maximal (pic de charge instantanée) pouvant être appliqué au réducteur, ne doit pas dépasser 200% du couple nominal M_{max} .

C. Charges Radiales

Vérifier que les charges radiales agissant sur les arbres d'entrée et/ou de sortie respectent les valeurs admises dans le catalogue. Si elles sont supérieures, augmenter la taille du réducteur ou modifier le palier de la charge extérieure.

Durant la phase de vérification, il est nécessaire de tenir compte du fait que les valeurs indiquées dans le catalogue se réfèrent à des charges agissant sur la moitié de la partie saillante de l'arbre; par conséquent, en cas d'application de la charge dans une position différente, il est nécessaire de déterminer la charge admissible dans la position désirée à l'aide des formules spéciales (voir paragraphe "Charges radiales" page 21).

ES

INFORMACIÓN TÉCNICO

Selección de los reductores

1. Determinar el factor de servicio de la aplicación (f_b) (ver el párrafo "Factor de servicio" pág. 9).
2. Calcular la relación de reducción i entre la velocidad de salida n_2 requerida y la de entrada n_1

$$i = \frac{n_1}{n_2}$$

3. Obtener el momento de torsión MG para seleccionar el reductor a través del par necesario para la aplicación MH y el factor de servicio f_b :

$$MG = MH \cdot (f_b)$$

4. Consultar las tables de las prestaciones de los reductores buscando el reductor que, con la relación de reducción más próxima a la calculada, disponga de un par nominal M_2 tal que:

$$M_2 \geq MG$$

Verificaciones

Una vez realiza la selección del reductor o del motorreductor es conveniente efectuar las siguientes verificaciones:

A. Potencia Térmica

La potencia térmica del reductor debe ser mayor o igual que la potencia mecánica instalada o que la potencia requerida por la aplicación según las indicaciones contenidas en la sección (ver el párrafo "Potencia térmica" pág 13).

B. Par Máximo

Generalmente el par máximo (pico de carga instantáneo) que se puede aplicar al reductor no debe superar el 200% del par nominal M_{max} .

C. Cargas Radiales

Verificar que las cargas radiales que actúan sobre los árboles de entrada y/o de salida respeten los valores admitidos según el catálogo. Si son mayores, aumentar el tamaño del reductor o modificar la capacidad de soportar la carga externa. En la fase de verificación, es necesario tener en cuenta que los valores indicados en el catálogo se refieren a carga está aplicada en una posición diferente, es necesario determinar la carga admisible en la posición deseada con las fórmulas correspondientes (ver el párrafo "Cargas Radiales" pág. 21).

DE **BETRIEBSFAKTOR**

Der Betriebsfaktor (f_B) hängt von den Betriebsbedingungen ab, unter denen das Getriebe betrieben wird. Die Parameter, die für eine korrekte Auswahl des Betriebsfaktors zu berücksichtigen sind, sind folgende:

- Belastungsart der angetriebenen Maschine: **U - M - H**
- Tägliche Betriebsdauer: **Std./Tag (Δ)**
- Anlaufrequenz: **Anl./Std. (*)**

LAST :	U - Gleichförmig	$m_{af} \leq 0.3$
	M - Mittlere Überlast	$m_{af} \leq 3$
	H - Hohe Überlast	$m_{af} \leq 10$

$m_{af} = J_e/J_m$

- m_{af} Massenträgheitswert
 - J_e (kgm^2) äußeres Trägheitsmoment reduziert auf die Motorwelle
 - J_m (kgm^2) Motor-Trägheitsmoment
- Bei $m_{af} > 10$ bitte mit unserem Kundendienst Kontakt aufnehmen.

U- Schneckenförderer für Leichtmaterial, Gebläse, Montagebänder, Bandförderer für Leichtmaterial, kleine Rührwerke, Kleinlastenaufzüge, Kreiselpumpen, Hebebühnen, Reinigungsmaschinen, Abfüllmaschinen, Prüfmaschinen, Bandförderer.

M- Wickelmaschinen, Vorrichtungen zur Zuführung bei Holzbearbeitungsmaschinen, Lastaufzüge, Auswuchtmaschinen, Gewindeschneidmaschinen, mittlere Rührwerke und Mischer, Bandförderer für schwere Materialien, Winden, Schiebetore, Dünger Abkratzer, Verpackungsmaschinen, Betonmischmaschinen, Kranfahr- und Kranhubwerke, Fräsmaschinen, Biegemaschinen, Zahnradpumpen, Hubstapler, Drehtische.

H- Rührwerke für schwere Materialien, Scheren, Pressen, Schleudern, Winden und Aufzüge für schwere Materialien, Schleifmaschinen, Steinbrecher, Kettenbecherwerke, Bohrmaschinen, Hammermühlen, Exzenterpressen, Biegemaschinen, Drehtische, Scheuertrommeln, Vibrationsrüttler, Schneidemaschinen, Stanzen, Walzwerke, Zementmühlen.

EN **SERVICE FACTOR**

The service factor (f_B) depends on the operating conditions the reduction unit is subjected to. The parameters that need to be taken into consideration to select the most adequate service factor correctly comprise:

- Type of load of the operated machine: **U - M - H**
- Length of daily operating time: **hours/day (Δ)**
- Start-up frequency: **starts/hour (*)**

TYPE OF LOAD:	U - Uniform	$m_{af} \leq 0.3$
	M - Moderate shocks	$m_{af} \leq 3$
	H - Heavy shocks	$m_{af} \leq 10$

$m_{af} = J_e/J_m$

- m_{af} Factor of inertia
 - J_e (kgm^2) moment of reduced external inertia at the drive - shaft
 - J_m (kgm^2) moment of inertia of motor
- If $m_{af} > 10$ call our Technical Service.

U- Screw feeders for light materials, fans, assembly lines, conveyor belts for light materials, small mixers, lifts, cleaning machines, fillers, control machines.

M- Winding devices, woodworking machine feeders, goods lifts, balancers, threading machines, medium mixers, conveyor belts for heavy materials, winches, sliding doors, fertilizer scrapers, packing machines, concrete mixers, crane mechanisms, milling cutters, folding machines, gear pumps.

H- Mixers for heavy materials, shears, presses, centrifuges, rotating supports, winches and lifts for heavy materials, grinding lathes, stone mills, bucket elevators, drilling machines, hammer mills, cam presses, folding machines, turntables, tumbling barrels, vibrators, shredders.

IT **FATTORE DI SERVIZIO**

Il fattore di servizio (f_B) dipende dalle condizioni di funzionamento alle quali il riduttore è sottoposto. I parametri che occorre considerare per una corretta selezione del fattore di servizio più adeguato sono:

- Tipo del carico della macchina azionata: **U - M - H**
- Durata di funzionamento giornaliero: **ore/giorno (Δ)**
- Frequenza di avviamento: **avv/ora (*)**

TIPO DEL CARICO:	U - Uniforme	$m_{af} \leq 0.3$
	M - Medio	$m_{af} \leq 3$
	H - Forte	$m_{af} \leq 10$

$m_{af} = J_e/J_m$

- m_{af} fattore d'inertzia
 - J_e (kgm^2) momento d'inertzia esterno ridotto all'albero motore
 - J_m (kgm^2) momento d'inertzia motore
- Se $m_{af} > 10$ interpellare il ns. Servizio Tecnico.

U- Coclee per materiali leggeri, ventole, linee di montaggio, nastri trasportatori per materiali leggeri, piccoli agitatori, elevatori, macchine pulitrici, macchine riempitrici, macchine per il controllo, nastri trasportatori.

M- Dispositivi di avvolgimento, apparecchi per l'alimentazione delle macchine per il legno, montacarichi, equilibratrici, filettatrici, agitatori medi e mescolatori, nastri trasportatori per materiali pesanti, verricelli, porte scorrevoli, raschiatore di concime, macchine per l'imballaggio, betoniere, meccanismi per il movimento delle gru, frese, piegatrici, pompe a ingranaggi.

H- Agitatori per materiali pesanti, cesoie, presse, centrifughe, supporti rotanti, verricelli ed ascensori per materiali pesanti, torni per la rettifica, frantoi da pietre, elevatori a tazze, perforatrici, mulini martello, presse ad eccentrico, piegatrici, tavole rotanti, barilatrici, vibratori, trinciatrici.

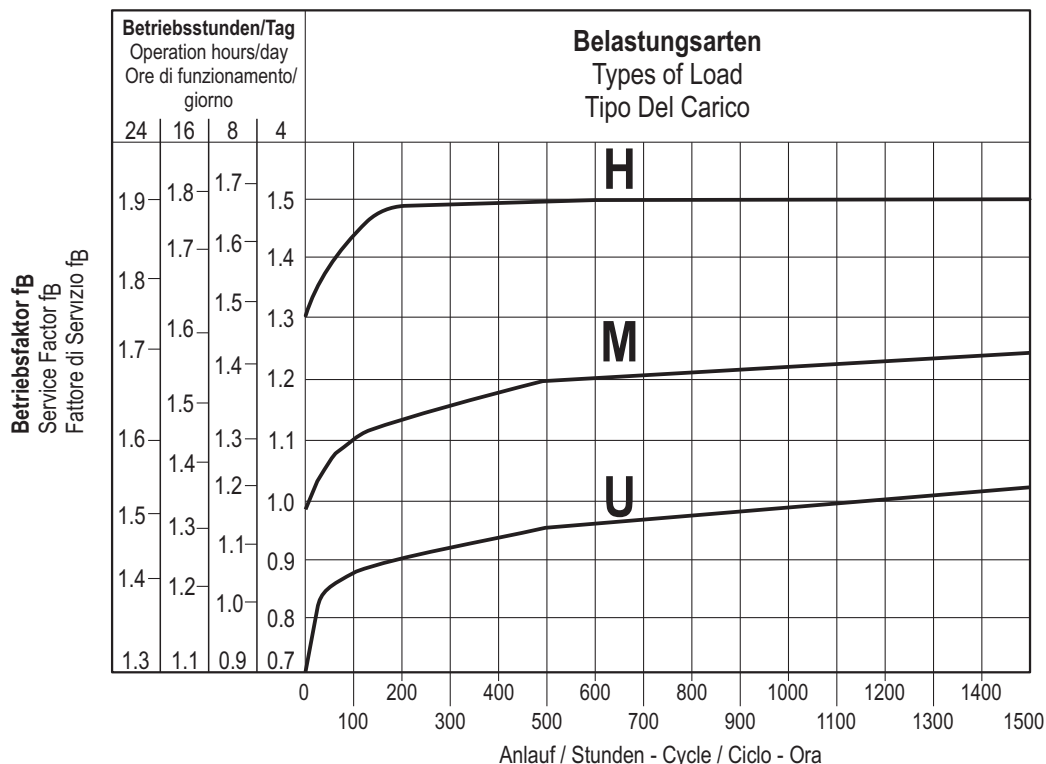

FR

FACTEUR DE SERVICE

Le facteur de service (fb) est subordonné aux conditions de fonctionnement auxquelles le réducteur est soumis. Les paramètres qu'il faut considérer pour un choix correct du facteur de service adéquat sont les suivants:

- Type de charge de la machine actionnée: U - M - H
- Durée de fonctionnement journalière: heures / jour (Δ)
- Fréquence de démarrage: dém / heure (*)

TYPE DE CHARGE:	U - Uniforme	maf ≤ 0,3
	M - Surcharge moyenne	maf ≤ 3
	H - Surcharge forte	maf ≤ 10

maf = Je/Jm

- maf facteur d'inertie
 - Je (kgm²) moment d'inertie extérieur ramené à l'arbre-moteur
 - Jm (kgm²) moment d'inertie moteur
- En cas de maf > 10, contacter notre S.ce Technique.

ES

FACTOR DE SERVICIO

El factor de servicio (fb) deende de las condiciones de funcionamiento a las cuales está sometido el reductor. Los parámetros que deben ser considerados para una correcta selección del factor de servicio más adecuado son:

- Tipo de carga de la máquina accionada: **U - M - H**
- Duración de funcionamiento diario: **horas/día (Δ)**
- Frecuencia de arranques: **arr/hora (*)**

TIPO DE CARGA:	U - Uniforme	maf ≤ 0,3
	M - Sobrecarga media	maf ≤ 3
	H - Sobrecarga fuerte	maf ≤ 10

maf = Je/Jm

- maf factor de inercia
 - Je (kgm²) inercia externa reducida al eje motor
 - Jm (kgm²) inercia motor
- En caso de maf > 10, ponerse en contacto con nuestro Servicio Técnico.

U- Vis d'Archimède pour matériaux légers, ventilateurs, lignes de montage, convoyeurs pour matériaux légers, petits agitateurs, élévateurs, machines à nettoyer, machines à remplir, machines pour le contrôle, convoyeurs.

U- Tornillos de Arquímedes para materiales ligeros, ventiladores, líneas de montaje, cintas transportadoras para materiales ligeros, pequeños agitadores, elevadores, máquinas limpiadoras, máquinas llenadoras, máquinas comprobadoras, cintas trasportadoras.

M- Dispositifs d'enroulement, appareils pour l'alimentation des machines pour le bois, monte-charges, équilibreuses, taraudeuses, agitateurs moyens et mélangeurs, convoyeurs pour matériaux lourds, treuils, portes coulissantes, racleurs d'engrais, machines à emballer, bétonnières, mécanismes pour le mouvement des grues, fraises, plieuses, pompes à engrenages.

M- Dispositivos de enrollado, alimentadores de las máquinas para la madera, montacargas, equilibradores, roscadoras, agitadores medios y mezcladores, cintas transportadoras para materiales pesados, cabrestantes, puertas corredizas, raspadores de abono, máquinas empaquetadoras, hormigoneras, mecanismos para el movimiento de las grúas, fresadoras, plegadoras, bombas de engranajes.

H- Agitateurs pour matériaux lourds, cisailles, presses, centrifugeuses, supports rotatifs, treuils et ascenseurs pour matériaux lourds, tours pour la rectification, concasseurs de pierres, élévateurs à godets, perceuses, moulins à marteaux, presses à excentrique, plieuses, tables tournantes, polisseuses, vibreurs, machines à hacher.

H- Agitadores para materiales pesados, cizallas, prensas, centrifugadoras, soportes rotativos, cabrestantes y elevadores para materiales pesados, tornos para la rectificación, molinos de piedras, elevadores de cangilones, perforadoras, molidores a percusión, prensas de excéntrica, plegadoras, mesas giratorias, pulidoras, vibradores, cortadoras.

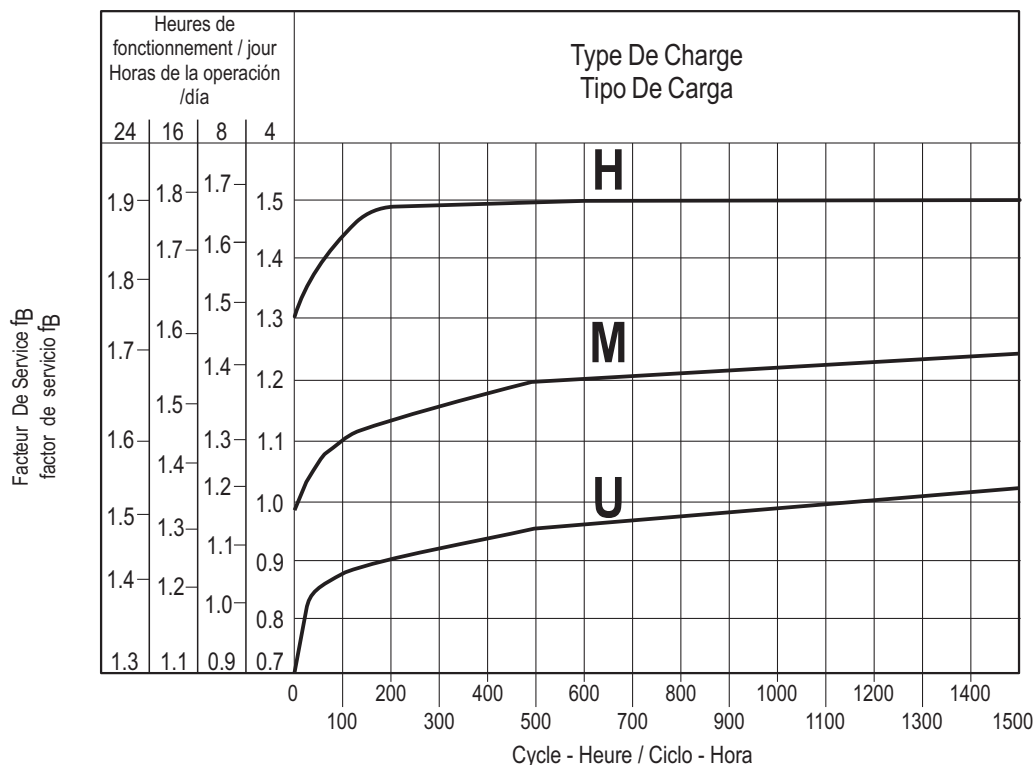

DE KRITISCHE ANWENDUNGEN

Die im Katalog aufgeführten Leistungsdaten gelten für die Einbaulage M1 oder gleichwertig, wenn das Ritzel nicht völlig mit Öl geschmiert wird.
Für andere Einbaulagen und / oder besondere Antriebsdrehzahlen sind die Tafeln zu beachten, die verschiedene kritische Zustände für jede Getriebegröße darstellen. Darüber hinaus sind nachstehende Anwendungen zu beachten und eventuell sollte mit unserem Kundendienst Kontakt aufgenommen werden:

- Anwendungen mit sehr hohen Trägheitsmomenten.
- Anwendungen mit hohen dynamischen Beanspruchungen auf Getriebegehäuse.
- Einsatz bei Umgebungstemperaturen unter -5°C oder über 40°C.
- Nicht im Katalog vorgesehene Einbaulagen.
- Anwendungen, die bei Bruch des Getriebes für den Menschen gefährlich sein könnten.
- Einsatz als Übersetzungsgetriebe (Übersetzung ins Schnelle).
- Einsatz als Hebewinde.
- Einsatz unter einem Druck, der nicht dem normalen Luftdruck entspricht.
- Einsatz in Verbindung mit aggressiven chemischen Substanzen.
- Einsatz unter Salzwassereinwirkung.
- Einsatz unter radioaktiver Strahlung.

Anwendungen, bei denen das Eintauchen des Getriebes in Wasser vorgesehen ist (auch teilweise), sollen vermieden werden. Das max. zulässige Drehmoment (*) des Getriebes, darf nicht den zweifachen Wert des in der Leistungstabelle angegebenen nominalen Wert des Drehmomentes (fb =1) übersteigen.

(*) Hierbei sind Überlasten gemeint, welche durch Anlaufen unter Vollast, Bremsungen, Stöße und weiter dynamische Ursachen, hervorgerufen werden.

EN CRITICAL APPLICATIONS

The performance given in the catalogue correspond to mounting position M1 or similar, ie. when the first stage is not entirely immersed in oil. For other mounting positions and/or particular input speeds, refer to the tables that highlight different critical situations for each size of reduction unit. It is also necessary to take due consideration of and carefully assess the following applications by calling our Technical Service:

- Applications with especially high inertia.
- Applications with high dynamic strain on the case of the reduction unit.
- In places with T° under -5°C or over 40°C
- Mounting positions not envisaged in the catalogue.
- Use in services that could be hazardous for people if the reduction unit fails..
- As a speed increasing.
- Use as a lifting winch.
- Use in environments pressures other than atmospheric pressure.
- Use in chemically aggressive environments.
- Use in a salty environment
- Use in radioactive environments.

Avoid applications where even partial immersion of the reduction unit is required.

The maximum torque (*) that the gear reducer can support must not exceed two times the nominal torque (fb=1) stated in the performance tables.

(*) intended for momentary overloads due to starting at full load,braking, shocks or other causes, particularly those that are dynamic.

IT APLICAZIONI CRITICHE

Le prestazioni indicate a catalogo corrispondono alla posizione M1 o similari, quando cioè il primo stadio non è interamente immerso in olio. Per situazioni di piazzamento diverse e/o velocità di ingresso particolari attenersi alle tabelle che evidenziano situazioni critiche diverse per ciascuna taglia di riduttore. Occorre anche tenere nella giusta considerazione e valutare attentamente le seguenti applicazioni consultando il ns. Servizio Tecnico:

- Applicazioni con inerzie particolarmente elevate.
- Applicazioni con elevate sollecitazioni dinamiche sulla cassa del riduttore.
- Utilizzo in ambiente con T° inferiore a -5°C o superiore a 40°C
- Posizioni di piazzamento non previste a catalogo.
- Utilizzo in servizi che potrebbero risultare pericolosi per l'uomo in caso di rottura del riduttore.
- Utilizzo come moltiplicatore.
- Utilizzo come organo di sollevamento.
- Utilizzo in ambiente con pressione diversa da quella atmosferica.
- Utilizzo in ambiente con presenza di aggressivi chimici.
- Utilizzo in ambiente salmastro.
- Utilizzo in ambiente radioattivo.

Evitare applicazioni dove è prevista l'immersione, anche parziale, del riduttore. La coppia massima (*) sopportabile dal riduttore non deve superare il doppio della coppia nominale (fb =1) riportata nelle tabelle delle prestazioni.

(*)intesa come sovraccarico istantaneo dovuto a avviamenti a pieno carico, frenature, urti ed altre cause soprattutto dinamiche.

A/F	202	202 G	252 - 253	301-302-303	351-352-353	401-402-403	501-502-503	601-602-603	701-702-703	902-903
M4 : 1500 < n1 < 3000	P	P	-	-	-	-	-	-	P	P
n1 > 3000	X	X	P	P	P	P	P	P	X	X
M2	P	P	P	P	P	P	P	P	P	P

X Nicht empfohlene Anwendung
Application not recommended
Applicazione sconsigliata

P Anwendung überprüfen und/oder mit unserem Kundendienst Kontakt aufnehmen.
Check the application and/or call our technical service.
Verificare l'applicazione e/o contattare il ns. servizio tecnico.

FR APPLICATIONS CRITIQUES

Les performances indiquées sur le catalogue correspondent à la position M1 ou similaires, lorsque le premier train d'engrenage n'est pas entièrement immergé dans l'huile. Pour les combinaisons d'assemblage différentes et/ou les vitesses d'entrée particulières, se conformer aux tableaux qui mettent en évidence les différentes situations critiques pour chaque taille de réducteur. Il faut aussi prendre en considération et évaluer attentivement les applications suivantes, en consultant notre S.ce Technique:

- Applications avec inerties particulièrement élevées.
- Applications avec sollicitations dynamiques sur la carcasse du réducteur.
- Emploi en milieu avec température au - dessous de -5°C ou au-dessus de 40°C.
- Positions de montage non prévues sur le catalogue.
- Emploi en services qui pourraient être dangereux pour l'homme en cas de rupture du réducteur.
- Emploi comme multiplicateur.
- Emploi comme treuil, en cas de soulèvement.
- Emploi en milieu ayant une pression différente de celle atmosphérique.
- Emploi en milieu en présence d'agents chimiques agressifs.
- Emploi en milieu saumâtre.
- Emploi en milieu radioactif.

Eviter les applications dans lesquelles l'immersion du réducteur, même si partielle, est prévue. Le couple maximum (*) supporté par le réducteur ne doit pas être supérieur au double du couple nominal ($f_B=1$) suivant notre table de prestation.

(*) Entendu comme surcouple instantané dû à démarrages en pleine charge, freinages, chocs et autres causes surtout dynamiques.

ES APLICACIONES CRITICAS

Las prestaciones indicadas en el catálogo corresponden a la posición M1 o similares, cuando el primer tren de engranajes no está completamente inmerso en el aceite. Para posiciones de montaje distintas y/o de velocidades particulares a la entrada, atenerse a las tablas que ponen en evidencia las distintas situaciones críticas por cada tamaño de reductor. Además es necesario considerar y evaluar cuidadosamente las siguientes aplicaciones, poniéndose en contacto con nuestro Servicio técnico:

- Aplicaciones con inercias particularmente elevadas.
- Aplicaciones con esfuerzos dinámicos elevados sobre la carcasa del reductor.
- Utilización en ambiente con T° inferior a -5°C o superior a 40°C.
- Posiciones en montaje no previstas en el catálogo.
- Utilización en servicios que, en caso de ruptura del reductor, podrían resultar peligrosos para el hombre.
- Utilización como multiplicador.
- Utilización como cabrestante de levantamiento.
- Utilización en ambiente con presión distinta de la atmosférica.
- Utilización en ambiente con presencia de agentes químicos agresivos.
- Utilización en ambiente salino.
- Utilización en ambiente radioactivo.

Evitar aplicaciones donde es prevista la inmersión, aún parcial, del reductor. El par máximo (*) soportable por el reductor no debe superar el doble del par nominal ($f_B=1$) indicado en la tabla de prestaciones.

(*) Entendida como sobrecarga instantánea debida a puestas en marcha a plena carga, frenados, impactos y otras causas sobretodo dinámicas.

A/F	202	202 G	252 - 253	301-302-303	351-352-353	401-402-403	501-502-503	601-602-603	701-702-703	902-903
M4 : 1500 < n1 < 3000	P	P	-	-	-	-	-	-	P	P
n1 > 3000	X	X	P	P	P	P	P	P	X	X
M2	P	P	P	P	P	P	P	P	P	P

X Application non conseillée
Aplicación desaconsejada

P Verifier l'application et/ou contacter notre s.ce technique.
Controlar la aplicación y/o ponerse en contacto con nuestro servicio técnico.

DE THERMISCHE LESITUNG Pt [kW]

Die folgende Tabelle enthält die Werte der thermischen Nennleistung in kW unter den folgenden Referenzbedingungen:

- Montageposition M1
- Dauerbetrieb mit Eingangsgeschwindigkeit ≤1500rpm
- Umgebungstemperatur von 25°C
- Höhe über dem Meeresspiegel
- Geschwindigkeit der Luft im Getriebeinneren ≥1m/s
- Abwesenheit von radialen und/oder axialen externen Belastungen

EN THERMAL POWER Pt [kW]

The table below list the nominal thermal power values expressed in kW, in the following reference conditions:

- mounting position M1
- continuous operation at input speed ≤1500 rpm
- ambient temperature 25°C
- sea level altitude
- air speed near the gear reducer ≥1m/s
- absence of external radial and/or axial loads

IT POTENZA TERMICA Pt [kW]

La seguente tabella riporta i valori di potenza termica nominale espressa in kW nelle seguenti condizioni di riferimento:

- posizione di montaggio M1
- funzionamento continuo con velocità di entrata ≤1500 rpm
- temperatura ambiente di 25°C
- altitudine pari al livello del mare
- velocità dell'intorno del riduttore ≥1m/s
- assenza di carichi radiali e/o assiali esterni

Thermische Leistungen bei 1500 rpm / Thermal power values at 1500 rpm / Potenza termiche a 1500 rpm	
Getriebe / Gear reducer / Riduttore	Pt [kW]
202	-
202 G	-
252 - 253	5.0
301	6.0
302 - 303	7.0
351	8.5
352 - 353	9.0
401	13.5
402 - 403	15.5
502 - 503	24.0
501	27.2
602 - 603	30.0
601	51.5
702 - 703	36.0
701	67.5
902 - 903	49.0

Durch die Anwendung einer die Pt nicht übersteigenden Leistung an das Getriebe wird eine ausreichende Schmierung und eine gute Funktionsweise des Getriebes gewährleistet.

Prüfung der Anwendung

Mit Ausnahme von durchgängigen Betriebszeiten unter zwei (2) Stunden und anschließenden Pausen, bei denen das Getriebe auf die Umgebungstemperatur abkühlt, ist es ratsam bei jeder Anwendung die thermische Grenze des Getriebes mit der folgenden Formel zu überprüfen:

$$P1 < Pt * Fc * Fv * Fa$$

dabei ist:

- P1** = Eingangleistung des Getriebes 1400 rpm (Motor mit 4 Polen)
- Pt** = Thermische Leistung unter Referenzbedingungen (siehe Tabelle oben)
- Fc** = Korrekturfaktor für Umgebungstemperatur und Betrieb
- Fv** = Korrekturfaktor für Belüftung
- Fa** = Korrekturfaktor für Höhe über NN

Die Korrekturfaktoren beziehen sich auf Betriebsbedingungen, die von den Referenzbedingungen abweichen und werden in den folgenden ISO14179 Tabellen aufgeführt:

Applying a power level not exceeding Pt at the above mentioned reference conditions guarantees the correct lubrication and efficient operation of the gear reducer.

Application check

Except for continuous operating times below two (2) hours and successive pauses capable of bringing the gear reducer back to ambient temperature, for each application it is advisable to verify the gear reducer's thermal limit according to the following formula:

$$P1 < Pt * Fc * Fv * Fa$$

where:

- P1** = input power to the gear reducer at 1.400 rpm (4-pole motors)
- Pt** = thermal power at reference conditions (see above table)
- Fc** = ambient and operating temperature correction factor
- Fv** = ventilation correction factor
- Fa** = altitude correction factor

The correction factors refer to different operating conditions compared to the reference conditions, and are provided by following ISO 14179 tables:

Applicando al riduttore, nelle suddette condizioni di riferimento una potenza non superiore a Pt, risultano garantiti una corretta lubrificazione ed il buon funzionamento del riduttore.

Verifica della applicazione

Fatta eccezione per tempi di funzionamento continuo inferiori a due (2) ore e successive pause in grado di riportare il riduttore a temperatura ambiente, per ogni applicazione è consigliabile eseguire la verifica del limite termico del riduttore, secondo la seguente formula:

$$P1 < Pt * Fc * Fv * Fa$$

dove:

- P1** = potenza in ingresso al riduttore a 1400 rpm (motori a 4 poli)
- Pt** = potenza termica in condizioni di riferimento (vedi tabella sopra)
- Fc** = fattore correttivo di temperatura ambiente e servizio
- Fv** = fattore correttivo di aerazione
- Fa** = fattore correttivo dell'altitudine

I fattori correttivi sono relativi a condizioni operative differenti da quelle di riferimento, e sono forniti dalle seguenti tabelle ISO14179:

FR PUISSANCE THERMIQUE Pt [kW]

Le tableau suivant présente les valeurs de puissance thermique nominale exprimées en kW dans les conditions de référence suivantes:

- position de montage M1
- fonctionnement continu avec vitesse d'entrée ≤= 1500tr/min
- température ambiante de 25°C
- altitude égale au niveau de la mer
- vitesse de l'air à proximité du réducteur ≥= 1m/s
- absence de charges radiales et/ou axiales externes

ES POTENCIA TÉRMICA Pt [kW]

La siguiente tabla contiene los valores de potencia térmica nominal expresada en kW en las siguientes condiciones de referencia:

- posición de montaje M1
- funcionamiento continuo con velocidad de entrada ≤=1500rpm
- temperatura ambiente de 25°C
- altura sobre el nivel del mar
- velocidad del aire en torno al reductor ≥=1m/s
- ausencia de cargas radiales y/o axiales externas

Puissances thermiques à 1500 rpm / Potencias térmicas a 1500 rpm	
Réducteur / Reductor	Pt [kW]
202	-
202 G	-
252 - 253	5.0
301	6.0
302 - 303	7.0
351	8.5
352 - 353	9.0
401	13.5
402 - 403	15.5
502 - 503	24.0
501	27.2
602 - 603	30.0
601	51.5
702 - 703	36.0
701	67.5
902 - 903	49.0

L'application au réducteur d'une puissance inférieure à la Pt, dans les conditions de référence indiquées ci-dessus, garantit une lubrification correcte et le bon fonctionnement du réducteur.

Vérification de l'application

À l'exception de périodes de fonctionnement continu inférieures à deux (2) heures et de pauses successives permettant au réducteur de redescendre à une température ambiante pour toute application, il est conseillé d'effectuer une vérification de la limite thermique du réducteur, selon la formule suivante

$$P1 < Pt * Fc * Fv * Fa$$

où:

- P1** = puissance d'entrée au réducteur à 1400tr/min (moteurs à 4 o-pôles)
- Pt** = puissance thermique dans les conditions de référence (voir tableau ci-dessus)
- Fc** = facteur de correction de température ambiante et de service
- Fv** = facteur de correction d'aération
- Fa** = facteur de correction de l'altitude

Les facteurs de correction correspondent à des conditions de fonctionnement différentes de celles de référence, et sont fournis par les tableaux ISO14179 suivants:

En las condiciones de referencia mencionadas, aplicando al reductor una potencia no mayor que la Pt, se garantiza una correcta lubricación y el buen funcionamiento del reductor.

Controlar la aplicación

Salvo cuando los tiempos de funcionamiento continuo son menores que dos (2) horas y se producen pausas capaces de llevar el reductor a la temperatura ambiente, para cada aplicación es aconsejable realizar la verificación del límite térmico del reductor, según la siguiente fórmula:

$$P1 < Pt * Fc * Fv * Fa$$

donde:

- P1** = potencia a la entrada del reductor a 1400rpm (motores de 4 polos)
- Pt** = potencia térmica en condiciones de referencia (ver la tabla de arriba)
- Fc** = factor de corrección de la temperatura ambiente y servicio
- Fv** = factor de corrección de aireación
- Fa** = factor de corrección de la altitud

Los factores de corrección son relativos a condiciones operativas diferentes a las de referencia y se encuentran en las siguientes tablas ISO14179:

DE THERMISCHE LEISTUNG Pt [kW]

EN THERMAL POWER Pt [kW]

IT POTENZA TERMICA Pt [kW]

Fc		Betriebszeit in % pro Stunde / Duty per hour of operation % / Servizio a carico ora di funzionamento %				
		100	80	70	40	20
Umgebungstemperatur Ambient temperature Temperatura ambiente	10°C	1.15	1.21	1.32	1.55	2.07
	18°C	1.07	1.12	1.23	1.44	1.93
	25°C	1.00	1.05	1.15	1.35	1.80
	30°C	0.93	0.98	1.07	1.26	1.67
	40°C	0.83	0.87	0.95	1.12	1.49
	43°C	0.75	0.79	0.86	1.01	1.35
	50°C	0.67	0.70	0.77	0.90	1.21

Geschwindigkeit der Umgebungsluft / Ventilation correction factor / Velocità dell'aria ambientale	Fv
Stehende Luft (<0,5 m/s) / Stagnant air (<0,5 m/s) / Aria stagnante (<0,5 m/s)	0.75
Installation in geschlossenen Räumen mit geringer Luftzirkulation / Indoor installation with slight ventilation / Installazione al chiuso con lieve aerazione	1
Installation in geschlossenen Räumen mit guter Luftzirkulation (>1,4 m/s) / Indoor installation with good ventilation (>1,4 m/s) / Installazione al chiuso con aerazione (>1,4 m/s)	1.4
Installation im Freien (>3,7 m/s) / Outdoor installation (>3,7 m/s) / Installazione all'aperto (>3,7 m/s)	1.9

Höhe über NN / Altitude correction factor / Altitudine	Fa
0*	1
750	0.95
1500	0.90
2250	0.85
3000	0.81

*Meeresniveau

*Sea level

*Livello del mare

Im Fall eines Betriebs mit Eingangsgeschwindigkeiten über 2000 rpm oder bei Umgebungstemperaturen über 40°C wird empfohlen, den Kundendienst zu kontaktieren.

In caso of operation at input speeds exceeding 2000 rpm, or ambient temperatures greater than 40°C it is advisable to contact out technical department.

In caso di funzionamento con velocità di ingresso maggiori di 2000 rpm, o temperature ambiente maggiori di 40°C è consigliabile contattare il ns servizio di assistenza.

FR PUISSANCE THERMIQUE Pt [kW]

ES POTENCIA TÉRMICA Pt [kW]

Fc		Facteur de marche par heure de fonctionnement % / Servicio con carga por hora de funcionamiento %				
		100	80	70	40	20
Température ambiante Temperatura ambiente	10°C	1.15	1.21	1.32	1.55	2.07
	18°C	1.07	1.12	1.23	1.44	1.93
	25°C	1.00	1.05	1.15	1.35	1.80
	30°C	0.93	0.98	1.07	1.26	1.67
	40°C	0.83	0.87	0.95	1.12	1.49
	43°C	0.75	0.79	0.86	1.01	1.35
	50°C	0.67	0.70	0.77	0.90	1.21

Vitesse de l'air ambiant / Velocidad del arie ambiental	Fv
Air stagnant (<0,5 m/s) / Aire estancado (<0,5 m/s)	0.75
Installation en intérieur avec une légère aération / Instalación cubierta con poca aireación	1
Installation en intérieur avec une aération correcte (>1,4 m/s) / Instalación cubierta con buena aireación (>1,4 m/s)	1.4
Installation en extérieur (>3,7 m/s) / Instalación al aire libre (>3,7 m/s)	1.9

Altitude / Altitud	Fa
0*	1
750	0.95
1500	0.90
2250	0.85
3000	0.81

*Niveau de la mer

*Nivel del mar

En cas de fonctionnement avec des vitesses d'entrée supérieures à 2000 tr/min ou en présence de températures ambiantes supérieures à 40°C, il est conseillé de contacter notre service d'assistance.

En el caso de funcionamiento con velocidades de entrada mayores que 2000 rpm o temperaturas ambiente mayores que 40°C es aconsejable llamar a nuestro servicio de asistencia técnica.

DE MONTAGE DES MOTORS AN DEN PAM-IEC FLANSCH B5

Bei Getrieben, welche ohne Motor geliefert werden, sind folgende Vorsichtsmaßnahmen zu beachten, um eine korrekte Montage des Elektromotors zu gewährleisten.

Übereinstimmung der Toleranzen von Welle und Motorflansch überprüfen.

Diese sollten mindestens DIN 42955 N entsprechen. Welle, Passung und Flanschfläche sind sorgfältig von Schmutz, Spänen oder Lackresten zu säubern.

Halbkupplung auf Motor (siehe Bild) einsetzen, andernfalls sind die korrekte Ausrichtung und die Toleranz der Paßfeder zu überprüfen. In jedem Fall sind solche Montageverfahren anzuwenden, die Schäden an den Motorlagern ausschließen.

Motor anbauen, wobei zuerst darauf geachtet werden muss, dass die Halbkupplung auf dem Motor und der elastische Zwischenring auf der Getriebehalbkupplung frei eingreifen können.

Keine Anpassung der Motorpaßfeder ist in diesem Fall erforderlich.

EN MOTOR MOUNTING WITH PAM FLANGE B5

When the unit is supplied without motor, it is necessary to follow these recommendation to ensure the correct assembly of the electric motor.

Check that the tolerances for the motor shaft and flange correspond to the standard.

Carefully clean the shaft, spigot and surfaces of the flange removing traces of paint and dirt, and confirm the key is fitted correctly.

Fit the half coupling to the motor shaft (see picture) taking care to ensure the motor shaft and bearings are not damaged by avoiding excessive force and where necessary using assembly equipment.

Place the couplings elastic element on to the motor half coupling and position the motor up to the gear unit ensuring the coupling element is aligned with the driven half coupling.

Complete the assembly using the fixing bolts. Key-ways with tightened tolerances.

IT MONTAGGIO MOTORE SU FLANGE PAM-IEC B5

Quando il gruppo viene fornito senza motore occorre osservare le seguenti raccomandazioni per garantire un corretto montaggio del motore elettrico.

Controllare che le tolleranze dell'albero e della flangia motore siano corrispondenti almeno a una classe di qualità "normale".

Pulire accuratamente l'albero, il centraggio ed il piano della flangia da sporco o tracce di vernice.

Procedere al montaggio del semigiunto (vedi figura) sull'albero del motore elettrico che deve avvenire senza eccessiva forzatura, in caso diverso controllare la coretta posizione e la tolleranza della linguetta motore;

Procedere quindi al montaggio del motore completo di semigiunto facendo i denti di trascinamento del semigiunto lato motore con quelli dell'elemento elastico presente sul semigiunto fisso lato riduttore.

Non è previsto nessun adattamento della linguetta motore.

FR INSTALLATION MOTEUR SUR BRIDE PAM-IEC B5

Quand le groupe est fourni sans moteur, observez les recommandations suivantes pour garantir un montage correct du moteur électrique.

Contrôler que les tolérances de l'arbre et de la bride du moteur correspondent au moins à une classe de qualité "normale".

Nettoyer soigneusement l'arbre, le centrage et le plan de la bride des traces de saleté et de peinture.

Procéder au montage de demi-accouplement sur l'arbre moteur électrique sans forcer (voir image), dans le cas contraire, vérifier la position correcte et la tolérance de la clavette du moteur.

Utiliser, toutefois, des systèmes appropriés qui garantissent un montage correct sans risquer de détériorer les roulements du moteur. Procéder de la même façon pour le montage du moteur avec le demiaccouplement coté moteur avec de l'élément élastique du demiaccouplement coté réducteur.

Rainures clavette moteur avec tolérances réduites.

ES MONTAJE DE MOTORES CON BRIDA B5

Si el equipo se suministra sin motor es preciso observar las siguientes recomendaciones para garantizar un correcto montaje del motor eléctrico.

Verificar que la tolerancia del eje y de la brida motor se correspondan al menos a una clase de calidad "normal".

Limpiar cuidadosamente el eje, el centrado y el plano de asiento de restos de barniz o suciedad.

Proceder al montaje del semiacoplamiento en el eje del motor eléctrico sin excesiva fuerza, si no entra con suavidad verificar la correcta tolerancia de la claveta del motor (ver imagen), utilizar en cualquier caso métodos de montaje que no dañen los rodamientos del motor.

Proceder a continuación al montaje del motor con el semiacoplamiento en el reductor, evitando la interferencia de los dientes del acoplamiento.

No se prevé ninguna adaptación de la claveta del motor.

ELASTISCHE KUPPLUNG / FLEXIBLE JOINT / GIUNTO ELASTICO / ACCOUP. ÉLASTIQUE / ACOPL. ELÁSTICO

A - F IEC

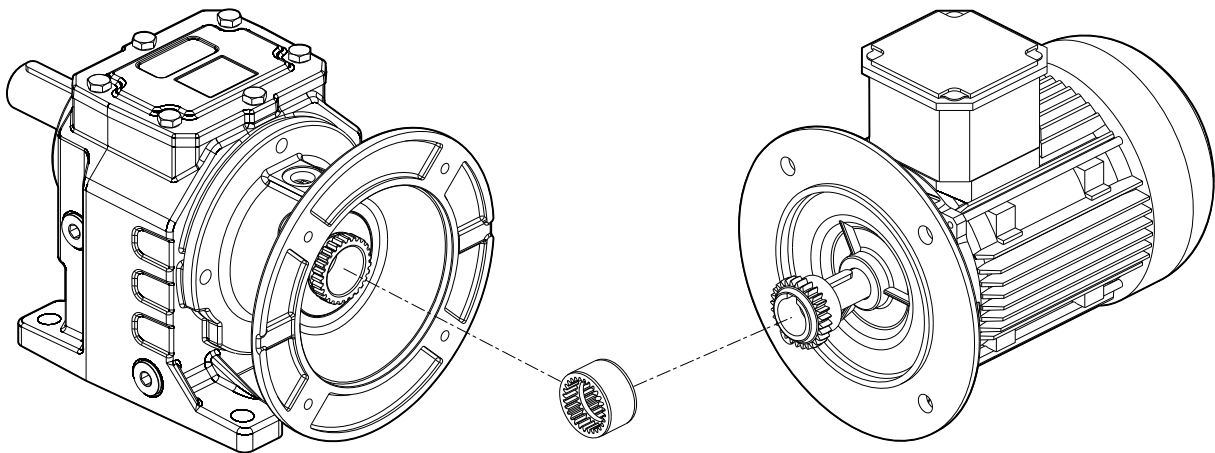

PAM BUCHSE / PAM SLEEVE / MANICOTTO PAM / MANCHON PAM / MANGUÍTO PAM

A - F PAM

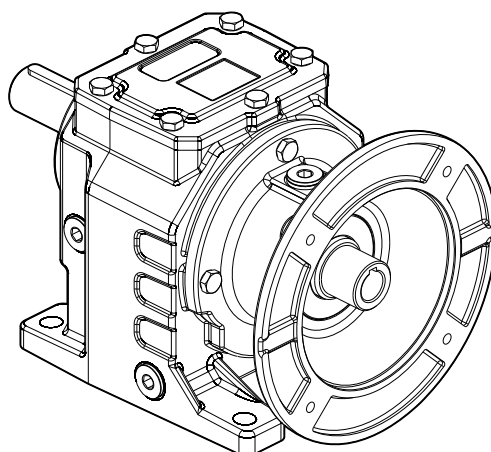

DE MONTAGE

Der korrekte Einbau des Getriebes in die entsprechende Vorrichtung der Applikation ist Voraussetzung, um einen einwandfreien und dauerhaften Betrieb zu gewährleisten. Vorallem die Oberflächen der Zentrierungen/Aufnahme sind in einer Toleranz H8 zu fertigen, damit die einwandfreie Uebereinstimmung mit der Getriebeachse garantiert wird. Für die Montage des Getriebes sind nachstehende Anweisungen zu beachten:

- Für im Freien betriebene Maschinen wird empfohlen, das Getriebe soweit wie möglich vor Witterungseinflüssen zu schützen sowie mit Rostschutzmittel zu behandeln. Die Dichtringe sind mit wasserabweisendem Fett zu versehen.
- Für die Befestigung sind die Schrauben zu verwenden, die in der Zeichnung / Teileliste des Modells vorgesehen sind. Dazu sind alle vorgesehenen Befestigungsbohrungen zu verwenden
- Der Anbau des Getriebes an Elektro oder Hydraulikmotor erfolgt normalerweise direkt über Flansche; vor allem, wenn eine außergewöhnliche Situation vorliegt, die nach erfolgtem Einbau Schäden verursachen könnte.
- Die Befestigung an der Maschine muss absolut stabil sein, um jegliche Vibrationen zu vermeiden.
- Vor der Montage des Getriebes an die Maschine ist die Abtriebswelle des Getriebes auf die richtige Drehrichtung zu prüfen.
- Nach besonders langer Einlagerung (4/6 Monate) ist zu überprüfen, ob die Wellendichtringe vom Schmiermittel des Getriebes vollständig benetzt wurden; Andernfalls ist ein Austausch anzuraten, da die Dichtlippe auf der Welle festkleben kann oder die zum einwandfreien Betrieb notwendige Elastizität nicht mehr vorhanden ist.
- Die Motorkühlung muss durch eine gute Belüftung durch den Lüfter gewährleistet werden. Bei Umgebungstemperaturen < -5°C oder > +40°C setzen Sie sich bitte mit dem Kundendienst in Verbindung.
- Zur Montage der unterschiedlichen Anbauteile (Riemenscheiben, Zahnräder, Kupplungen, Wellen usw.) auf den Hohl- oder Vollwellen sind die vorgesehenen Gewindebohrungen oder Aufziehvorrichtungen zu verwenden.
- Diese gewährleisten eine einwandfreie Montage, ohne die Lager oder die Außenteile des Getriebes zu beschädigen. Die in Berührung kommenden Passungen und Oberflächen der Wellen sind zu fetten/ölen, um ein Festfressen durch Passungsrost zu vermeiden.
- Bei Lackierung ist darauf zu achten, dass alle Gummiteile und fallweise die in den Entlüftungsdeckeln vorhandenen Bohrungen nicht überlackiert werden.
- Bei Getrieben mit Ölstopfen ist die zum Transport verwendete Verschlusschraubendurch die beigelegte Entlüftungsschraube zu ersetzen.
- Der Schmierölstand ist an der Füllstandanzeige zu überprüfen, sofern vorhanden. Der Antrieb ist stufenweise in Betrieb zu nehmen, wobei zunächst mit Teillast angefahren werden sollte.
- Sind unter dem Antrieb Geräteteile oder Materialien angeordnet, die durch geringe Mengen austretenden Öls beschädigt werden könnten, so ist eine geeignete Schutzvorrichtung vorzusehen.

EN INSTALLATION

For the longest and most efficient service life, drives must be correctly mounted on the application structure. Therefore, all structure faces must be machined with H8 spigots so that they are flat and perpendicular to the drive axis. To install the reduction unit it is necessary to note the following Recommendations:

- For outdoor installations, drives must be protected against bad weather, treated with anticorrosive agents and oil seals protected with water-repellent grease.
- To secure the drive, use the nuts and bolts shown under each technical drawing on the product technical sheets. Make sure to use all the fixing holes on the flanges.
- Drives are usually connected directly to what are mainly electric or hydraulic motors by means of flanges when there are particularly critical conditions that might cause damage after installation.
- The mounting on the machine must be stable to avoid any vibration.
- Before installing gearbox to your machine, please check rotation direction of output shaft is correct or not.
- Check the correct direction of rotation of the storage (4/6 months), if the oil seal is not immersed in the lubricant inside the unit, it is recommended to change it since the rubber could stick to the shaft or may even have lost the elasticity it needs to function properly.
- Ensure the motor cools correctly by assuring good passage of air from the fan side. In the case of ambient temperatures < -5°C or > +40°C call the Technical Service.
- The various parts (pulleys, gear wheels, couplings, shafts, etc.) must be mounted on the solid or hollow shafts using special threaded holes or other systems that anyhow ensure correct operation without risking damage to the bearings or external parts of the units. Lubricate the surfaces in contact to avoid seizure or oxidation.
- Painting must definitely not go over rubber parts and the holes on the breather plugs, if any.
- For units equipped with oil plugs, replace the closed plug used for shipping with the special breather plug.
- Check the correct level of the lubricant through the indicator, if there is one. Starting must take place gradually, without immediately applying the maximum load.
- When there are parts, objects or materials under the motor drive that can be damaged by even limited spillage of oil, special protection should be fitted.

IT INSTALLAZIONE

Per garantire un buon funzionamento de riduttori ed una miglior durata nel tempo è necessario un corretto accoppiamento alla struttura cui viene fissato il gruppo. Pertanto le superfici di tale struttura dovranno essere lavorate con centraggi in H8 ed in modo da garantire un'ottima planarità e perpendicolarità con l'asse del riduttore. Per l'installazione del riduttore è consigliabile attenersi alle seguenti indicazioni:

- Per gruppi installati all'aperto si consiglia dove possibile, di proteggere i riduttori dalle intemperie, di trattarli con sistemi anticorrosivi e di proteggere i paraoli con grasso idrorepellente.
- Per il fissaggio del riduttore usare la bulloneria indicata sotto ogni disegno nelle schede tecniche di prodotto. Usare inoltre tutti i fori di fissaggio previsti sulle flange dei riduttori.
- L'abbinamento fra riduttori e motori, principalmente elettrici o idraulici, viene normalmente fatto mediante flangiatura diretta quando non si presentano particolari condizioni di criticità, che possono provocare danni dopo l'installazione.
- Il fissaggio sulla macchina deve essere stabile per evitare qualsiasi vibrazione.
- Verificare il corretto senso di rotazione dell'albero di uscita del riduttore prima del montaggio del gruppo sulla macchina.
- In caso di periodi particolarmente lunghi di stoccaggio (4/6 mesi) se l'anello di tenuta non è immerso nel lubrificante contenuto all'interno del gruppo si consiglia la sua sostituzione in quanto la gomma potrebbe essersi incollata all'albero o addirittura aver perso quelle caratteristiche di elasticità necessarie al corretto funzionamento.
- Garantire un corretto raffreddamento del motore assicurando un buon passaggio d'aria dal lato ventola. Nel caso di temperature ambiente < -5°C o > +40°C contattare il servizio Assistenza Tecnica.
- Il montaggio dei vari organi (pulegge, ruote dentate, giunti, alberi, ecc.) sugli alberi pieni o cavi deve essere eseguito utilizzando appositi fori filettati o altri sistemi che comunque garantiscano una corretta operazione senza rischiare il danneggiamento dei cusci netti o delle parti esterne dei gruppi.
- Lubrificare le superfici a contatto per evitare grippaggi o ossidazioni.
- La verniciatura non deve assolutamente interessare le parti in gomma e i fori esistenti sui tappi di sfiato, quando presenti.
- Per i gruppi provvisti di tappi per olio sostituire il tappo chiuso utilizzato per la spedizione con l'apposito tappo di sfiato.
- Controllare il corretto livello del lubrificante tramite, quando prevista, l'apposita spia. La messa in funzione deve avvenire in maniera graduale, evitando l'applicazione immediata del carico massimo.
- Quando sotto alla motorizzazione sono presenti organi, cose o materiali danneggiabili dall'eventuale fuoriuscita, anche limitata, di olio è opportuno prevedere un'apposita protezione.

FR

INSTALLATION

Pour garantir le bon fonctionnement des réducteurs et leur durée de vie maximum, il est indispensable d'assurer un bon accouplement à la structure sur laquelle le groupe doit être fixé. Aussi, les surfaces de cette structure doivent être usinées par des centrages en H8 et de façon à garantir une planéité optimale et une perpendicularité par rapport à l'axe du réducteur. Pour l'installation du réducteur, il faut se conformer aux indications suivantes:

- Pour les groupes installés à ciel ouvert, il est conseillé, dans la mesure du possible, de mettre les réducteurs à l'abri des intempéries, de les traiter avec des produits anti-corrosion et de protéger les joints d'étanchéité à l'aide de la graisse hydrofuge.
- Pour effectuer la fixation du réducteur, utiliser les boulons indiqués sous chaque dessin de s fiches techniques du produit. En outre, utiliser tous les trous de fixation prévus sur les brides des réducteurs.
- L'assemblage des réducteurs aux moteurs principalement électriques ou hydrauliques, est généralement assuré par bridage direct en l'absence de conditions critiques particulières susceptibles d'endommager l'installation.
- La fixation sur la machine doit être stable pour éviter toute vibration.
- Avant le montage du groupe sur la machine, vérifier que le sens de rotation de l'arbre de sortie du réducteur soit correct.
- En cas de périodes de stockage particulièrement longues (4/6 mois), si la bague d'étanchéité n'est pas immergée dans le lubrifiant contenu à l'intérieur du groupe, on conseille son remplacement, car le caoutchouc pourrait être collé à l'arbre ou avoir perdu les caractéristiques d'élasticité nécessaires à un fonctionnement correct.
- Vérifier que le refroidissement du moteur soit suffisant, en assurant un bon passage d'air du côté ventilateur. En cas de températures ambiante < -5°C ou > +40°C, contacter le S.ce techniques.
- Le montage de différents organes (poulies, roues dentées, accouplements, arbres, etc.) sur les arbres pleins ou creux doit être effectué en utilisant les trous filetés ou d'autres systèmes assurant de toute façon une opération correcte, sans risquer d'endommager les roulements ou les parties extérieures des groupes. Lubrifier les surfaces en contact, afin d'éviter le grippage ou l'oxydation.
- La peinture ne doit absolument pas toucher les parties en caoutchouc et, si présents, les trous sur les bouchons d'évent.
- Pour les groupes avec bouchons d'huile, remplacer le bouchon, utilisé lors de l'expédition, par le bouchon d'évent.
- Contrôler, grâce au voyant (si prévu), que le niveau du lubrifiant correspond. La mise en marche doit s'effectuer d'une façon graduelle, en évitant l'application immédiate de la charge maximale.
- Si des organes, des choses ou des matériels pouvant être endommagés par l'éventuelle sortie d'huile, même si limitée, sont présents sous la motorisation, il faut prévoir une protection adéquate.

ES

INSTALACIÓN

Para garantizar un buen funcionamiento de los reductores y una mayor duración se deberá realizar un correcto acoplamiento a la estructura en la que se fija el grupo. Por tanto las superficies de dicha estructura tendrán que estar bien planas y los ejes de los agujeros respetar una tolerancia H8, de este modo se podrá garantizar una óptima planaridad y perpendicularidad con el eje del reductor. Para la instalación del reductor, atenerse a las siguientes indicaciones:

- Para los grupos instalados al aire libre se aconseja, donde sea posible, proteger los reductores contra la intemperie, tratarlos con sistemas contra la corrosión y proteger los sellos de lubricación con grasa hidrófuga.
- Para efectuar la fijación del reductor, utilizar los tornillos indicados en cada uno de los dibujos de las fichas técnicas del producto. Además, utilizar todos los agujeros de fijación previstos en las bridas de los reductores.
- El montaje entre los reductores y los motores, principalmente eléctricos o hidráulicos, generalmente se realiza con embrizado directo siempre que no se presenten particulares condiciones críticas que podrían ocasionar daños después de la instalación.
- Para evitar las vibraciones, la fijación sobre la máquina tiene que ser estable.
- Antes del montaje del grupo sobre la máquina, controlar que el sentido de rotación del eje de salida del reductor sea correcto.
- En caso de periodos de almacenamiento muy largos (4/6 meses), si el retén no está sumergido en el lubricante contenido en el grupo, se aconseja su reemplazo porque la goma podría estar pegada al eje o haber perdido las características de elasticidad necesarias para un funcionamiento correcto.
- Controlar que la refrigeración del motor sea suficiente, asegurando una correcta transferencia de aire del lado ventilador. En caso de temperatura ambiente de < -5°C o > +40°C, ponerse en contacto con el Servicio técnico.
- El montaje de distintos órganos (poleas, ruedas dentadas, acoplamientos, ejes, etc.) sobre los ejes llenos o huecos debe ser efectuado utilizando los agujeros roscados correspondientes u otros sistemas, asegurando de todas maneras una operación correcta sin correr el riesgo de dañar los cojinetes o las partes externas de los grupos.
- Lubricar las superficies en contacto para evitar los gripados o las oxidaciones.
- El barnizado no debe cubrir las partes de goma y los agujeros en los existentes tapones - respiraderos. Para los grupos equipados de tapones de aceite, reemplazar el tapón cerrado, utilizado durante el transporte, por el tapón respiradero.
- Controlar, por medio del indicador (si previsto), que el nivel del lubricante corresponda. La puesta en marcha se debe producir de manera gradual evitando la aplicación súbita de la carga máxima.
- Si bajo el reductor hay mecanismos, cosas o materiales que puedan dañarse por una eventual pérdida de aceite, deberá preverse una protección adecuada.

DE QUERBELASTUNGEN - TECHNISCHE BESCHREIBUNGEN

Der Wert der zulässigen Querbelastrung (N) wird in den Tafeln über die Leistungen des betreffenden Getriebes aufgeführt und ist die Kraft, die auf die Mittellinie der Wellen unter ungünstigsten Bedingungen wie Anwendungswinkel und Drehrichtung einwirkt.

Die zulässigen Axialbelastungen betragen 1/5 der aufgeführten Querbelastrungen, wenn diese gleichzeitig einwirken.

Die Tafeln über die Abtriebswellen geben den für die Lager bzw. das Gehäuse zulässigen Höchstwert an; dieser Wert darf nie überschritten werden.

Falls die im Katalog aufgeführten Grenzwerte doch überschritten werden sollten, setzen Sie sich bitte mit unserem Kundendienst in Verbindung und nennen Sie ihm alle Anwendungsdaten wie Belastungsrichtung, Drehrichtung der Welle, Anwendungsart.

Sofern die Anwendung mit einer beidseitigen Einleitung der Querkraft arbeitet, ist die Anwendung hinsichtlich der Einsatzbedingungen zu überprüfen. Hierzu kontaktieren Sie bitte unser technisches Büro.

Die Querbelastrung (Querkraft) auf der Welle wird durch nachstehende Formel berechnet:

$$FR_{XL} = \frac{2000 \cdot M_2 \cdot fz}{d_o} \leq FR_1 \text{ o } FR_2$$

FR_{XL} (N)
Resultierende Querkraft
M₂ (Nm)
Wellendrehmoment
d_o (mm)
Durchmesser des an der Welle montierten Antriebselements
FR (N)
Max. zul. Querkraft FR₁ - FR₂ (siehe entspr. Tafel).

fz = 1,1 Zahnrad
1,4 Rad für Kette
1,7 Flanschscheibe
2,5 Flachriemenscheibe

Sofern die resultierende Querkraft nicht auf die Mitte der Welle bezogen ist, ist die effektive Kraft FR₁₋₂ durch Formel zu berechnen:

$$FR_X = \frac{FR_{1-2} \cdot z}{(y + x)}$$

y, z = siehe Tafeln auf Seite 22.
x = Abstand der Querkraft zur Wellenschulter.

EN RADIAL LOADS - TECHNICAL DESCRIPTIONS

The value of the admissible radial load (N) is given in the tables relating to the performance of the reduction unit at its sue. It is related to the load applied on the centre line of the shaft and in the most unfavourable conditions of angle of application and direction of rotation.

The maximum admissible axial loads are 1/5 of the value of the given radial load when are applied in combination with the radial load.

The tables relating to the output shafts give the maximum admissible value.

This value must never be exceeded since it relates to the strength of the case.

Particular conditions of radial load higher than the limits of the catalogue may occur. In this case, call our Technical Service and provide details on the application: direction of the load, direction of rotation of the shaft, type of service.

In case of double extension shafts with radial load applied on both ends, the max. admissible radial loads must be defined according to the specific running conditions, in this case call our Technical Service.

The radial load on the shaft is calculated with the following formula:

$$FR_{XL} = \frac{2000 \cdot M_2 \cdot fz}{d_o} \leq FR_1 \text{ o } FR_2$$

FR_{XL} (N)
Resulting radial load
M₂ (Nm)
Torque on the shaft
d_o (mm)
Diameter of the transmission member mounted on the shaft
FR (N)
Value of the maximum admitted radial load FR₁ - FR₂ (see relative tables).

fz = 1,1 Gear pinion
1,4 Chain wheel
1,7 V-pulley
2,5 Flat pulley

When the resulting radial load is not applied on the centre line of the shaft it is necessary to adjust the admissible radial load FR₁₋₂ with the following formula:

$$FR_X = \frac{FR_{1-2} \cdot z}{(y + x)}$$

y, z = values given in the tables on page 22.
x = distance from the point of application of the load to the shaft shoulder.

IT CARICHI RADIALI - DESCRIZIONI TECNICHE

Il valore del carico radiale (N) ammissibile viene riportato nelle tabelle relative alle prestazioni del riduttore in same, ed è relativo al carico applicato sulla mezzeria dell'albero e nelle condizioni più sfavorevoli come angolo di applicazione e senso di rotazione.

I carichi assiali massimi ammissibili sono 1/5 del valore del carico radiale indicato quando sono applicati in combinazione col carico radiale stesso.

Nelle tabelle relative agli alberi di uscita viene indicato il valore massimo ammissibile, questo valore non deve mai essere superato in quanto è relativo alla resistenza della cassa. Possono essere verificate condizioni particolari di carico radiale superiori ai limiti di catalogo, in questo caso contattare il ns. Servizio Tecnico.

Servizio Tecnico e fornire tutti i dati applicativi: direzione del carico, senso di rotazione dell'albero, tipo di servizio.

Nel caso di alberi bisporgenti e cavi in cui è previsto l'applicazione di carichi radiali su entrambe le estremità, i carichi massimi ammissibili sono da definire in funzione delle condizioni di esercizio specifiche, in questo caso contattare il ns. Servizio Tecnico.

Il carico radiale sull'albero si calcola con la seguente formula:

$$FR_{XL} = \frac{2000 \cdot M_2 \cdot fz}{d_o} \leq FR_1 \text{ o } FR_2$$

FR_{XL} (N)
Carico radiale risultante
M₂ (Nm)
Momento torcente sull'albero
d_o (mm)
Diametro dell'elemento di trasmissione montato sull'albero
FR (N)
Valore di carico radiale massimo ammesso FR₁ - FR₂ (ved. tab.relative)

fz = 1,1 Pignone dentato
1,4 Ruota per catena
1,7 Puleggia a gola
2,5 Puleggia piana

Quando il carico radiale risultante non è applicato in mezzeria dell'albero occorre correggere il carico radiale ammissibile FR₁₋₂ con la seguente formula:

$$FR_X = \frac{FR_{1-2} \cdot z}{(y + x)}$$

y, z = valori riportati nelle tabelle pag. 14
x = distanza del punto di applicazione del carico da spallamento albero.

FR

**CHARGES RADIALES -
DESCRIPTIONS TECHNIQUES**

La valeur de la charge radiale (N) admissible est indiquée dans les tableaux concernant les performances du réducteur examiné et correspond à la charge appliquée sur la ligne médiane de l'arbre, dans les conditions les plus défavorables au niveau de l'angle d'application et du sens de rotation.

Les charges axiales maximales admissibles sont 1/5 de la valeur de la charge radiale indiquée, au cas où elles seraient appliquées en combinaison avec la charge radiale même.

Les tableaux concernant les arbres de sortie indiquent la valeur maximale admissible, valeur qui ne doit jamais être dépassée car elle correspond à la résistance de la carcasse.

Des conditions particulières de charges radiales supérieures aux limites de catalogue peuvent être vérifiées; dans ce cas, contacter notre Service Technique en donnant toutes les données d'application: direction de la charge, sens de rotation de l'arbre, type de service.

Dans le cas d'arbre double avec une charge radiale appliquée aux deux extrémités, la charge radiale maximale admissible doit être définie selon les conditions de fonctionnement spécifiques, dans ce cas contacter notre service technique.

La charge radiale sur l'arbre doit être calculée selon la formule suivante:

$$FR_{XL} = \frac{2000 \cdot M_2 \cdot fz}{d_o} \leq FR_1 \text{ o } FR_2$$

FR_{XL} (N)
Charge radiale résultante
M₂ (Nm)
Torque on the shaft
d_o (mm)
Diameter of the transmission member mounted on the shaft
F_R (N)
Valeur de charge radiale maximum admise FR₁ - FR₂
(voir table aux correspondants)

fz = 1,1 Pignon denté
1,4 Roue pour chaîne
1,7 Pouile à gorge
2,5 Pouile plate

Quand la charge radiale résultante n'est pas appliquée au milieu de l'arbre, il est nécessaire de corriger la charge radiale admissible FR₁₋₂ avec la formule suivante:

$$FR_X = \frac{FR_1 - 2 \cdot z}{(y + x)}$$

y, z = valeurs indiquées dans les tableaux à page 14.
x = distance entre le point d'application de la charge et l'épaulement de l'arbre.

ES

**CARGAS RADIALES -
DESCRIPCIONES TECNICAS**

El valor de carga radial (N) admisible es indicado en las tablas relacionadas a las prestaciones del reductor examinado y se refiere a la carga aplicada sobre la línea de centro del eje y en las condiciones más desfavorables como ángulo de aplicación y sentido de rotación.

Las cargas axiales máximas admisibles son 1/5 del valor de carga radial indicado, cuando están aplicadas en combinación con la carga radial misma.

En las tablas relacionadas a los ejes de salida se indica el valor máximo admisible; nunca se debe superar este valor, porque se refiere a la resistencia de la carcasa.

Podrían presentarse condiciones particulares de carga radial superiores a los límites de catálogo; en este caso, ponerse en contacto con nuestro Servicio técnico e indicar todos los datos de la aplicación: dirección de carga, sentido de rotación del eje, tipo de servicio.

En caso de ejes dobles o huecos sobre los que se prevea la aplicación de cargas radiales sobre ambos extremos, las cargas máximas admisibles se deben definir en función de las características de la aplicación, en ese caso contactar a nuestro Servicio Técnico.

La carga radial sobre el eje se calcula con la siguiente fórmula:

$$FR_{XL} = \frac{2000 \cdot M_2 \cdot fz}{d_o} \leq FR_1 \text{ o } FR_2$$

FR_{XL} (N)
Carga radial resultante
M₂ (Nm)
Par de torsión sobre el eje
d_o (mm)
Diamètre de l'élément de transmission monté sur l'arbre
F_R (N)
Valor de carga radial máximo admitido FR₁ - FR₂ (ver tablas correspondientes)

fz = 1,1 Piñon dentado
1,4 Piñon de cadena
1,7 Polea para correa trapezoidal
2,5 Polea plana

Quando la carga radial resultante no se aplica sobre el centro del eje de salida, se debe corregir la carga radial admisible FR₁₋₂ mediante la siguiente fórmula:

$$FR_X = \frac{FR_1 - 2 \cdot z}{(y + x)}$$

y, z = valores indicados en las tablas pág. 14.
x = distancia desde el punto de aplicación de la carga hasta la base del eje.

DE QUERBELASTUNGEN - TECHNISCHE BESCHREIBUNGEN

EN RADIAL LOADS - TECHNICAL DESCRIPTIONS

IT CARICHI RADIALI - DESCRIZIONI TECNICHE

FR CHARGES RADIALES - DESCRIPTIONS TECHNIQUES

ES CARGAS RADIALES - DESCRIPCIONES TECNICAS

Abtriebswellen

Sofern die radiale Querkraft nicht auf die Mitte der Welle bezogen ist, ist die effektive zulässige Kraft FRX durch folgende Formel zu berechnen:

Output Shafts

When the radial load is not on the centre line of the shaft, it is necessary to adjust the admissible radial load FRX with the following formula:

Ejes de Salida

Si la carga radial resultante no se aplica sobre el centro del eje, corregir la carga radial admisible FRX mediante la siguiente fórmula:

Arbres de Sortie

Quand la charge radiale n'est pas au milieu de l'arbre, il est nécessaire de corriger la charge radiale admisible FRX avec la formule suivante:

Alberi in Uscita

Con carico radiale risultante non in mezziera dell'albero, correggere il carico radiale ammissibile FRX con la formula:

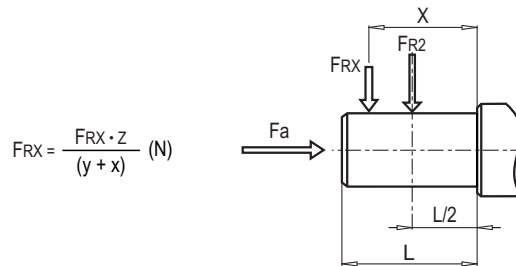

A/F	301	351	401	501	601	701
z	89	98	115	151	210	232
y	79	73	85	111	155	177
FR2 max (**)	1000	2500	3700	4000	5000	6000
Fa max (*)	5500	6500	7000	8500	11500	13500

A/F	202	202 G	252-253	302-303	352-353	402-403	502-503	602-603	702-703	902-903
z	86,5	103	120	138	169	195	238	281	331	367
y	66,5	83	96	108	134	155	188	221	261	282
FR2 max(**)	2500	2800	5500	6600	8000	12000	18000	22000	30000	55000

(**FR2) Entspricht dem max. zulässigen Getriebewert; bitte beachten sie den max. Wert de Tabelle.

(**FR2) Max. admissible value of the reducer; verify max. admissible value on performance tables.

(**FR2) Valore massimo ammesso dal riduttore; verificare valore massimo ammesso su tabelle di prestazioni.

(**FR2) Valeur maximale admissible du réducteur; vérifier la valeur maxi admissible dans les tableaux de performances.

(**FR2) Valor máximo admisible por el reductor; verificar el valor máximo admisible en las tablas de preestaciones.

(*) Die Werte der maximal zulässigen Axialkräfte beziehen sich auf eine Drehrichtung bei verbautem Axiallager (auf Anfrage).

(*) Maximum axial load values admissible in only one direction with the use of a thrust bearing (on request).

(*) Valori di carico assiale massimo ammissibile in una sola direzione per versione con cuscinetto reggispinta (a richiesta).

(*) Valeurs de charge axiale maximum admissible dans une seule direction pour la version avec roulements coniques (sur demande).

(*) Valores de la fuerza axial maxima admisible en un unico sentido con rodamiento axial (bajo demanda).

DE QUERBELASTUNGEN - TECHNISCHE BESCHREIBUNGEN
FR CHARGES RADIALES - DESCRIPTIONS TECHNIQUES

EN RADIAL LOADS - TECHNICAL DESCRIPTIONS
ES CARGAS RADIALES - DESCRIPCIONES TECNICAS

IT CARICHI RADIALI - DESCRIZIONI TECNICHE

Antriebswellen

Sofern die radiale Querkraft nicht auf die Mitte der Welle bezogen ist, ist die effektive zulässige Kraft FRX durch folgende Formel zu berechnen:

Arbres D'entree

Quand la charge radiale n'est pas au milieu de l'arbre, il est nécessaire de corriger la charge radiale admissible FRX avec la formule suivante:

Input Shafts

When the radial load is not on the centre line of the shaft, it is necessary to adjust the admissible radial load FRX with the following formula:

Ejes de Entrada

Si la carga radial resultante no se aplica sobre el centro del eje, corregir la carga radial admissible FRX mediante la siguiente fórmula:

Alberi in Entrata

Con carico radiale risultante non in mezzeria dell'albero, correggere il carico radiale ammissibile FRX con la formula:

$$FRX = \frac{FR1 \cdot z}{(y + x)} \quad (N)$$

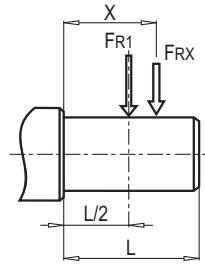

A/F - W	301	351	401	501	601	701
z	105	105	105	137	175	175
y	80	80	80	108	135	135
FR1 max (**)	1320	1800	2200	2500	3000	3000

A/F - W	202	202 G	252-253	302-303	352-353	402-403	502-503	602-603	702-703	902-903
z	-	-	105	105	105	137	137	175	175	225
y	-	-	80	80	80	108	108	135	135	170
FR1 max (**)	-	-	2200	2200	2500	3600	3600	7200	7200	15000

(**FR1) Entspricht dem max. zulässigen Getriebewert; bitte beachten sie den max. Wert de Tabelle.

(**FR1) Max. admissible value of the reducer; verify max. admissible value on performance tables.

(**FR1) Valore massimo ammesso dal riduttore; verificare valore massimo ammesso su tabelle di prestazioni.

(**FR1) Valeur maximale admissible du réducteur; vérifier la valeur maxi admissible dans les tableaux de performances.

(**FR1) Valor máximo admisible por el reductor; verificar el valor máximo admisible en las tablas de preestaciones.

DE TRÄGHEITSMOMENTE

Die angegebenen Werte sind Richtwerte und beziehen sich auf Getriebe mit PAM Eingangsflansch.
Die angegebenen Werte beziehen sich jeweils auf das max. Massenträgheitsmoment.

EN MOMENTS OF INERTIA

Following values are indicative only and refer to gear reducers fitted with input PAM.
These values refer to maximum moment of inertia.

IT MOMENTI D'INERZIA

I seguenti valori sono solo indicativi. Sono riferiti a riduttori già predisposti con l'attacco motore PAM.
I valori in tabelle sono riferiti al massimo di quelli calcolati.

FR MOMENTS D'INERTIE

Les valeurs suivantes sont seulement indicatives et se rapportent à des réducteurs de vitesse équipés avec l'entrée PAM.
Ces valeurs sont relatives au moment d'inertie maximum.

ES MOMENTOS DE INERCIA

Los valores siguientes son sólo indicativos y se refieren a los reductores con PAM de entrada.
Estos valores están referidos al momento de inercia máximo.

A - F - AF	J*1E-4 [Kg*m2]
202	-
202 G	-
252 - 253	0,7
301	0,8
302 - 303	0,7
351	1,9
352 - 353	0,9
401	4,6
402 - 403	2,0
502 - 503	6,8
501	11,0
602 - 603	10,6
601	34,5
702 - 703	28,2
701	76,4
902 - 903	44,2

DE SCHMIERUNG

Bei in der Tafel nicht vorgesehenen Umgebungstemperaturen setzen Sie sich bitte mit unserem Kundendienst in Verbindung.

Bei Temperaturen unter -30°C oder über 60°C werden Dichtringe aus besonderen Elastomeren benötigt.

Bei Betrieb mit Temperaturen unter 0°C ist folgendes zu berücksichtigen:

- 1- Die Motoren müssen für den Betrieb mit der vorgesehenen niedrigen Raumtemperatur geeignet sein.
- 2- Die Leistung des Elektromotors muss so ausgelegt werden, dass die höheren benötigten Anlaufdrehmomente aufgebracht werden können.
- 3- Bei Getriebehäusen aus Guß sind die Stoßbelastungen zu beachten, weil der Guß bei Temperaturen unter -15°C verspröden könnte.
- 4- Bei Betriebsbeginn könnten Schmierungsprobleme infolge der hohen Ölviskosität auftreten, daher ist es sinnvoll, für einige Minuten einen Leerlauf auszuführen. Je nach Umgebungsbedingungen und Betriebsart ist nach etwa 10.000 Betriebsstunden ein Ölwechsel durchzuführen.

EN LUBRICATION

In cases of ambient temperatures not envisaged in the table, call our Technical Service.

In the case of temperatures under -30°C or over 60°C it is necessary to use oil seals with special properties.

For operating ranges with temperatures under 0°C it is necessary to consider the following:

- 1- The motors need to be suitable for operation at the envisaged ambient temperature.
- 2- The power of the electric motor needs to be adequate for exceeding the higher starting torques required.
- 3- In case of cast-iron gear reducers, pay attention to impact loads since cast iron may have problems of fragility at temperatures under -15°C.
- 4- During the early stages of service, problems of lubrication may arise due to the high level of viscosity taken on by the oil and so it is wise to have a few minutes of rotation under no load.

The oil needs to be changed after approximately 10,000 hours. This period depends on the type of service and the environment where the reduction unit works.

IT LUBRIFICAZIONE

Nei casi con temperature ambiente non previste in tabella contattare il ns. Servizio Tecnico.

In caso di temperature inferiori a -30°C o superiori a 60°C occorre utilizzare anelli di tenuta con mescole speciali.

Per i campi di funzionamento con temperature inferiori a 0°C occorre considerare quanto segue:

- 1- I motori devono essere idonei al funzionamento con temperatura ambiente prevista.
- 2- La potenza del motore elettrico deve essere adeguata al superamento delle maggiori coppie di avviamento richieste.
- 3- Nel caso di riduttori con cassa in ghisa prestare attenzione ai carichi d'urto in quanto la ghisa può presentare problemi di fragilità a temperature inferiori ai -15°C.
- 4- Durante le prime fasi di servizio possono insorgere problemi di lubrificazione cause l'elevata viscosità che assume l'olio e quindi è opportuno procedere ad alcuni minuti di rotazione a "vuoto".

Il cambio olio deve essere eseguito dopo circa 10.000 ore, questo periodo è in funzione del tipo di servizio e dell'ambiente in cui opera il riduttore.

FR LUBRIFICATION

En cas de températures ambiantes non prévues dans le tableau, contacter notre Service Technique.

En cas de température au-dessous de -30°C ou au-dessus de 60°C, il faut utiliser des bagues d'étanchéité avec mélanges spéciaux.

Pour les champs de fonctionnement avec température au-dessus de 0°C, il faut considérer ce qui suit:

- 1- Les moteurs doivent être aptes au fonctionnement à la température ambiante prévue.
- 2- La puissance du moteur électrique doit être au-dessus de la plupart des couples de démarrage demandés.
- 3- En cas de réducteurs avec carcasse en fonte, faire attention aux charges de choc, car la fonte peut présenter des problèmes de fragilité à températures au-dessous de -15°C.
- 4- Lors des premières phases de service, des problèmes de lubrification dus à la viscosité élevée, que l'huile assume, pourraient se vérifier; il faut donc procéder à une rotation "à vide" de quelques minutes.

Le changement d'huile doit être effectué après 10,000 heures environ; cette période est en fonction du type de service et du milieu dans lequel le réducteur travaille.

ES LUBRICACIÓN

En caso de temperaturas no previstas en la tabla, ponerse en contacto con nuestro Servicio técnico.

En caso de temperaturas inferiores a -30°C o superiores a 60°C, es necesario utilizar anillos de retén con mezclas especiales. Para los campos de funcionamiento con temperaturas inferiores a 0°C, es necesario cumplir con lo que sigue:

- 1- Los motores tienen que ser idóneos al funcionamiento con la temperatura ambiente prevista.
- 2- La potencia del motor eléctrico tiene que ser idónea para superar los mayores pares de arranque pedidos.
- 3- En caso de reductores con carcasa de fundición, cuidado con las cargas de choque porque la fundición puede presentar problemas de fragilidad con temperaturas inferiores a los -15°C.
- 4- Durante las primeras fases de servicio podrían surgir unos problemas de lubricación debidos a la elevada viscosidad del aceite y es por lo tanto oportuno efectuar una rotación en "vacío" por algunos minutos.

El cambio de aceite tiene que ser efectuado aproximadamente después de 10.000 horas; claramente, este periodo es en función del tipo de ambiente en el que trabaja el reductor.

DE	SCHMIERUNG	EN	LUBRICATION	IT	LUBRIFICAZIONE
FR	LUBRIFICATION	ES	LUBRICACIÓN		

Mineralöl / Mineral Oil / Olio Minerale / Huile Minérale / Aceite Mineral							
	T°C ISO SAE...	ENI	SHELL	KLUBER	MOBIL	CASTROL	BP
A/F 301-701 A/F 202-902 A/F 253-903	(-5) / (+40) ISO VG220	BLASIA 220	OMALA OIL220	KLUBEROIL GEM 1-220N	MOBILGEAR 600 XP 220	ALPHA MAX 220	ENERGOL GR-XP220
	(-15) / (+25) ISO VG150	BLASIA 150	OMALA OIL150	KLUBEROIL GEM 1-150N	MOBILGEAR 600 XP 150	ALPHA MAX 150	ENERGOL GR-XP150

- Spezifische Schmierstoffangaben erfragen Sie bei NRW Drive Technologies.
- Specifications of lubricants recommended by NRW Drive Technologies.
- Specifiche dei lubrificanti consigliati da NRW Drive Technologies.
- Especificaciones de lubricante aconsejados por NRW Drive Technologies.
- Spécification des lubrifiants suivant NRW Drive Technologies.

- Für die Ölmengen siehe Seite 27.
- For the quantity of oil, please refer to the pages relating. (page 27)
- Per le quantità di olio si rimanda alle pagine relative. (pagina 27)
- Pour les quantités d'huile, voir pages concernant. (page 27)
- Para las cantidades de aceite, ver a las páginas. (página 27)

Spezialschmierstoffe / Special lubricants / Lubrificanti speciali / Lubrifiants spéciaux / Lubricantes especiales			
		*T°C	Synthetisches Öl / Synthetic oil / Olio sintetico / Huile synthétique / Aceite sintético
Öle für niedrige Temperaturen Oils for low temperature Oli per basse temperature Huiles pour basse température Aceites para bajas temperaturas	ENI	(-25) - (+20)	BLASIA 150 S (ISO VG150)
	KLUBER	(-35) - (+10)	KLUBERSYNTH GH 6-80 (ISO VG68)
	MOBIL	(-40) - (+5)	SCH 624 (ISO VG32)
	KLUBER	(-40) - (+5)	KLUBERSYNTH GH 6-32 (ISO VG32)
Öle für niedrige Temperaturen - Lebensmittelsektor Oils for low temperature - Food sector Oli per basse temperature - Settore alimentare Huiles pour basse température - Secteur de l'alimentation Aceites para bajas temperaturas - Sector alimentario	KLUBER	(-30) - (+10)	KLUBERSYNTH UH1-6 100 (ISO VG100)
Öle für hohe Temperaturen / Oils for high temperature / Oli per alte temperature / Huiles pour haute température / Aceites de alta temperatura	KLUBER	(-10) - (+50)	KLUBERSYNTH GH 6-460 (ISO VG460)
	KLUBER	(-10) - (+70)	KLUBERSYNTH GH 6-680 (ISO VG680)
Öle für hohe Temperaturen - Lebensmittelsektor Oils for high temperature - Food sector Oli per alte temperature - Settore alimentare Huiles pour haute température - Secteur de l'alimentation Aceites de alta temperatura - Sector alimentario /	KLUBER	(-10) - (+50)	KLUBERSYNTH UH1-6 460 (ISO VG460)
Lebensmittelsektor / Food sector / Settore alimentare / Secteur de l'alimentation / Sector alimentario	KLUBER	(-15) - (+40)	KLUBERSYNTH UH1-6 220 (ISO VG220)

Falls spezielles Öl verwendet werden soll kontaktieren sie bitte unseren Kundendienst
If 'special' lubricant is required please contact for Technical Assistance
Per l'utilizzo di lubrificanti speciali, contattare l'assistenza tecnica
Si un Lubrifiant spécial est demandé, merci de contacter notre service technique.
Para el uso de lubricantes especiales contactar con la asistencia técnica

* Betriebsumgebungstemperatur
* Working ambient temperature
* Temperatura ambiente di funzionamento
* Température ambiante de fonctionnement
* Temperatura ambiente de funcionamiento

DE SCHMIERUNG

- Für die Getriebe der Serie A/F ist die Einbaulage anzugeben.
 - Getriebe der Serie A/F mit 1 Übersetzungsstufe in den Baugrößen 30, 35, 40 und mit 2,3 Übersetzungsstufen in den Baugrößen 25, 30, 35, werden werkseitig mit Schmieröl befüllt. Sie bedürfen keinerlei Wartung und sind serienmäßig mit Ölstopfen ausgestattet.
 - Die Getriebe der Serie A/F mit 1 Übersetzungsstufe in den Baugrößen 50, 60, 70 und mit 2,3 Übersetzungsstufen in den Baugrößen 40, 50, 60, 70, 90 werden werkseitig mit Schmieröl, sowie Ölstopfen ausgeliefert. Die erforderliche Ölmenge und die Positionen der Ölschaugläsern entsprechen der werkseitig vorgeschlagenen Position. Vor der Inbetriebnahme sind die Verschlussstopfen, durch entsprechende Entlüftungsventile, gemäß der Einbaulage, auszutauschen.
 Die angegebenen Ölmenge sind Richtwerte. Diese müssen je nach Einbaulage, über Ölschaugläser, Ölstandsbohrungen der Ölmesstäbe (je nach Typ) regelmässig überprüft werden. Ölstandsunterschiede können aus verschiedenen Einbaulagen resultieren.
 Nach jeder Montage, sind alle Ölstände zwingend zu prüfen und gegebenenfalls anzupassen.

EN LUBRICATION

- For the reduction units A/F series it is always necessary to specify the mounting position.
 - A/F 1 stage 30, 35, 40 and 2,3 stage 25, 30, 35, are supplied complete with lubricant, have no oil plugs and need no maintenance
 - The gear reducer A/F series 1 stage 50, 60, 70 and 2,3 stage 40, 50, 60, 70, 90 are supplied complete with lubricant and are fitted with oil plugs to suit any mounting position included in the catalogue.
 It is recommended, after installation, to replace the closed plug used for transportation with the supplied breather plug. Lubricant quantities are only indicative, For correct filling always refer to the sight glass or the dipstick, when this is supplied.
 Any oil level differences can be caused by constructive tolerances but also on the mounting position or the assembly scheme of the customer Therefore it is very important for the customer to check oil level and if necessary to add the necessary quantity.

IT LUBRIFICAZIONE

- Per i riduttori serie A/F occorre sempre specificare la posizione di piazzamento prevista.
 - Serie A/F 1 stadio nelle grandezze 30,35,40 e serie A/F 2,3 stadi nelle grandezze 25,30,35 vengono forniti completi di lubrificante sono sprovvisti dei tappi olio e non hanno necessità di alcuna manutenzione
 - I riduttori serie A/F a 1 stadio nelle grandezze 50,60,70 e a 40,50,60,70,90 vengono forniti completi di lubrificante a dei tappi oli necessari a garantire la corretta lubrificazione nella posizione si piazzamento richiesta.
 Si raccomanda, effettuata l'installazione, di sostituire il tappo chiuso utilizzato per il trasporto con il tappo di sfiato fornito a corredo.
 Le quantità di olio in tabella sono solo indicative e per il corretto riempimento si dovrà fare riferimento al tappo o all'astina di livello, se presente.
 Eventuali scostamenti di livello possono dipendere da tolleranze costruttive ma anche dal piazzamento del riduttore o dal piano di montaggio presso cliente. Per tale motivo è opportuno che il cliente verifichi e, se necessario, ristabilisca il livello a riduttore installato.

FR LUBRIFICATION

- Pour les réducteurs série A/F il faut toujours spécifier la position de montage.
 - Série A/F à 1 train pour les grandeurs, 30,35,40 et série A/F 2,3 trains pour les grandeurs 25,30,35 sont fournis avec lubrifiant et sans bouchons et ne nécessitent, donc, aucun entretien.
 - Les réducteurs série A/F à 1 train pour les grandeurs 50,60, 70 et à 2,3 trains pour les grandeurs 40,50,60,70,90 sont fournis avec tous les bouchons nécessaires pour garantir toutes les positions de montage prévues au catalogue.
 On recommande, après l'installation, de changer le bouchon livré pour le transport contre celui fourni avec trou d'évent.
 Les quantités d'huile indiquées en tableau sont seulement indicatives et pour un remplissage correct il faut faire référence au bouchon de niveau ou à la jauge à huile, si présents.
 Toutes les différences de niveau d'huile peuvent être causées par des tolérances de constructions, ou par la position de montage, ou le schéma d'assemblage du client. Par conséquent il est très important que le client vérifie le niveau d'huile et au besoin ajoute la quantité nécessaire.

ES LUBRICACIÓN

- Para los reductores serie A/F es necesario especificar siempre la posición de montaje.
 - Serie A/F de 1tren en los tamaños, 30,35,40 y serie A/F de 2,3 trenes en los tamaños, 25,30,35 se suministran con lubricante, no disponen de tapón aceite y no necesitan ningún mantenimiento.
 - Los reductores serie A/F de 1 tren en los tamaños 50,60,70 y de 2,3 trenes en los tamaños 40,50,60,70,90 se suministran con lubricante y disponen de tapones para todas las posiciones de montaje previstas en el catálogo.
 Es necesario, una vez instalado el reductor en la máquina, sustituir el tapón cerrado, utilizado durante el transporte, por el tapón respiradero que se adjunta.
 Las cantidades de lubricante en la tabla son indicativas y para un correcto llenado hay que tomar de referencia el centra del visor o del asta de nivel si están instaladas.
 Eventuales diferencias del nivel de aceite pueden depender de tolerancias constructivas perotambién de la posición de montaje o del esquema de montaje del cliente. Por tanto es muy importante que el cliente compruebe el nivel de aceite y si es necesario agregue la cantidad adecuada.

A/F	301	351	401	501	601	701
M1	0.5	0.6	0.75	1.45	3.8	5.7
M2	0.35	0.45	0.45	1.5	3.2	4
M3	0.2	0.25	0.4	1.5	1.3	2.3
M4	0.5	0.65	0.9	1.5	2.7	6.5
M5-M6	0.35	0.45	0.6	1.5	2.6	4

- Ölmenge (Liter) ~
 - Quantity of oil in litres ~
 - Quantità olio in litri ~
 - Quantité d'huile en litres ~
 - Cantidad de aceite en litros ~

A/F	202	202 G	252 - 253	302 - 303	352 - 353	402 - 403	502 - 503	602 - 603	702 - 703	902 - 903
M1	0.16	0.30	0.8	1.2	1.5	3	5.7	10	16.7	29
M2	0.32	0.59	1.2	1.7	2	4.4	7.9	14.3	22.2	40
M3	0.21	0.42	1.1	1.3	1.8	3.6	6.2	11.2	16.9	28.5
M4	0.23	0.50	1.3	1.7	2.2	4.1	7.8	13.4	21.2	34.5
M5-M6	0.23	0.42	1	1.2	1.8	3.4	6.6	11	18.2	27.5

Anmerkung: M1 und M3 die montagepositionen werden in AF-M körpern geändert / **Note:** M1 and M3 mounting positions are changed in AF-M bodies / **Note:** Le posizioni di montaggio M1 e M3 vengono modificate negli corpo AF-M / **Notes:** Les positions de montage M1 et M3 sont modifiées dans les corps AF-M / **Notas:** Las posiciones de montaje M1 y M3 se cambian en cuerpos AF-M.

DE EINBAULAGE

EN MOUNTING POSITIONS

IT PIAZZAMENTO

FR POS. DE MONTAGE

ES POS. DE MONTAJE

- A...
- 202
 - 202 G
 - 252 - 253
 - 302 - 303
 - 352 - 353
 - 402 - 403
 - 502 - 503
 - 602 - 603
 - 702 - 703
 - 902 - 903

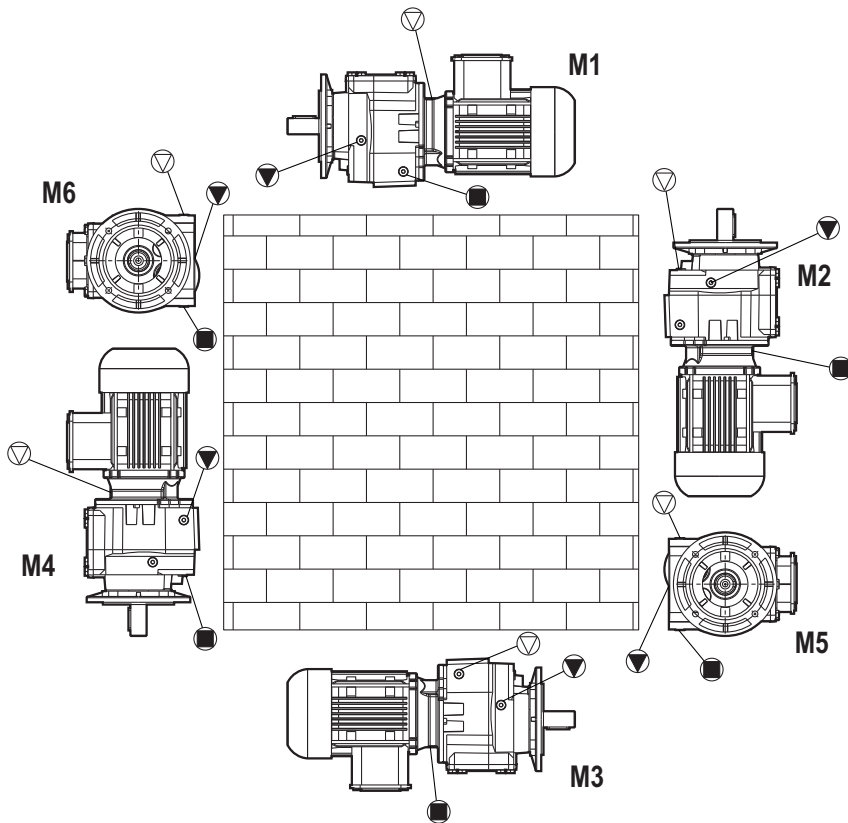
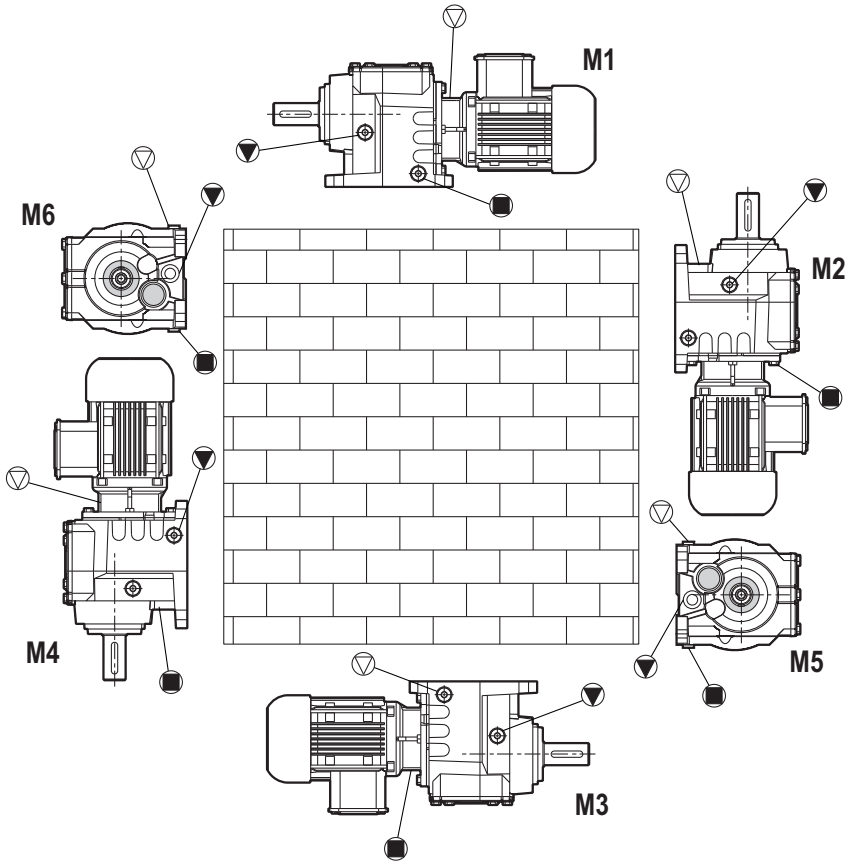

- | F... | AF... |
|-----------|-----------|
| 202 | 202 |
| 202 G | 202 G |
| 252 - 253 | 252 - 253 |
| 302 - 303 | 302 - 303 |
| 352 - 353 | 352 - 353 |
| 402 - 403 | 402 - 403 |
| 502 - 503 | 502 - 503 |
| 602 - 603 | 602 - 603 |
| 702 - 703 | 702 - 703 |
| 902 - 903 | 902 - 903 |

△ Entlüftung / Vent plug / Tappo di sfiato / Évent / Ventilación

■ Ölablass / Drain plug / Tappo di scarico dell'olio / Vidange d'huile / Vaciado de aceite

▽ Ölstand / Oil level / Tappo di livello dell'olio / Niveau d'huile / Nivel de aceite

DE

EINBAULAGE

- Für die vertikalen Einbaulagen siehe seite 10-11.
- Falls nicht anders angegeben, sind M1 die Standardeinbaulagen.
- Für nicht angegebene einbaulagen setzen sie sich bitte mit unserem Kundendienst in verbindung.

EN

MOUNTING POSITIONS

- For vertical positions, check with pages 10-11.
- Unless specified otherwise, the standard positions are M1.
- For positions not envisaged, it is necessary to call our Technical Service.

IT

PIAZZAMENTO

- Per le posizioni di piazzamento verticali verificare quanto detto a pag. 10-11.
- Se non diversamente specificato le posizioni standard sono M1.
- Per le posizioni di piazzamento non previste occorre rivolgersi al ns. Servizio tecnico.

FR

POS. DE MONTAGE

- Pour les positions de montage verticales, voir pages 10 et 11.
- Si non spécifié, les positions standard sont M1.
- Pour les positions de montage non prévues, contacter notre S.ce technique.

ES

POS. DE MONTAJE

- Para las posiciones de montaje verticales, ver las páginas 10-11.
- Si non se especifica el contrario, las posiciones estándar son M1.
- Para las posiciones demontajenoprevistas, es necesario ponerse en contacto con nuestro Servicio técnico.

A301...701
A202...902
A253...903

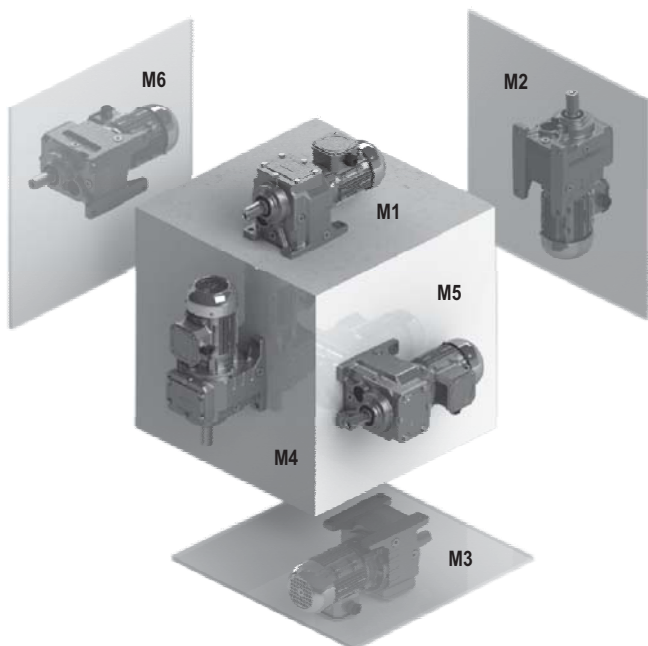

F301...701
F202...902
F253...903

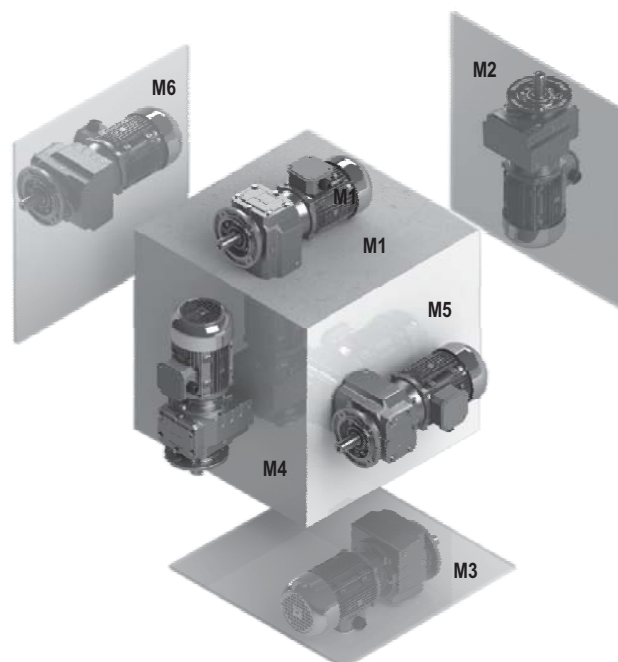

DE EINBAULAGE

- Im Falle von Sonderanforderungen ist bei Auftragserteilung die Lage des Klemmenkastens gemäß dem Schema genau anzugeben.
- Sofern nichts gegenteiliges angegeben, wird der Schneckengetriebemotor mit Klemmkastenlage 1 geliefert.
- Falls nicht anders angegeben, sind M1 die Standardeinbautagen.
- Für nicht angegebene Einbautagen setzen sie sich bitte mit unserem Kundendienst in Verbindung.

EN MOUNTING POSITIONS

- In the case of specific requirements, when ordering, specify the position of the terminal box as shown in the diagram.
- Unless other wise specified, the gear reducer is supplied with terminal box in position 1.
- Unless specified otherwise, the standard positions are M1.
- For positions not envisaged, it is necessary to call our Technical Service.

IT PIAZZAMENTO

- Nel caso di particolari esigenze specificare in fase di ordine la posizione della morsetteria come da schema.
- Se non diversamente specificato, il gruppo viene fornito con morsetteria in pos.1.
- Se non diversamente specificato le posizioni standard sono M1.
- Per le posizioni di piazzamento non previste to call our Technical Service.

FR POS. DE MONTAGE

- En cas d'exigences particulières, spécifier, lors de la commande, la position du bornier comme d'après le schéma.
- Sauf indications contraires, le réducteur est fourni avec boîte à borne en position 1.
- Si non spécifié, les positions standard sont M1.
- Pour les positions de montage non prévues, contacter notre S. ce technique.

ES POS. DE MONTAJE

- En caso de exigencias particulares, detallar en el pedido, la posición de la caja de bornes según el esquema.
- Si non esta diferentemente especificado, el motorreductor se monta con la caja de bornes en posición 1.
- Si no se especifica el contrario, las posiciones estándar son M1.
- Para las posiciones de montaje no previstas, es necesario ponerse en contacto con nuestro Servicio técnico.

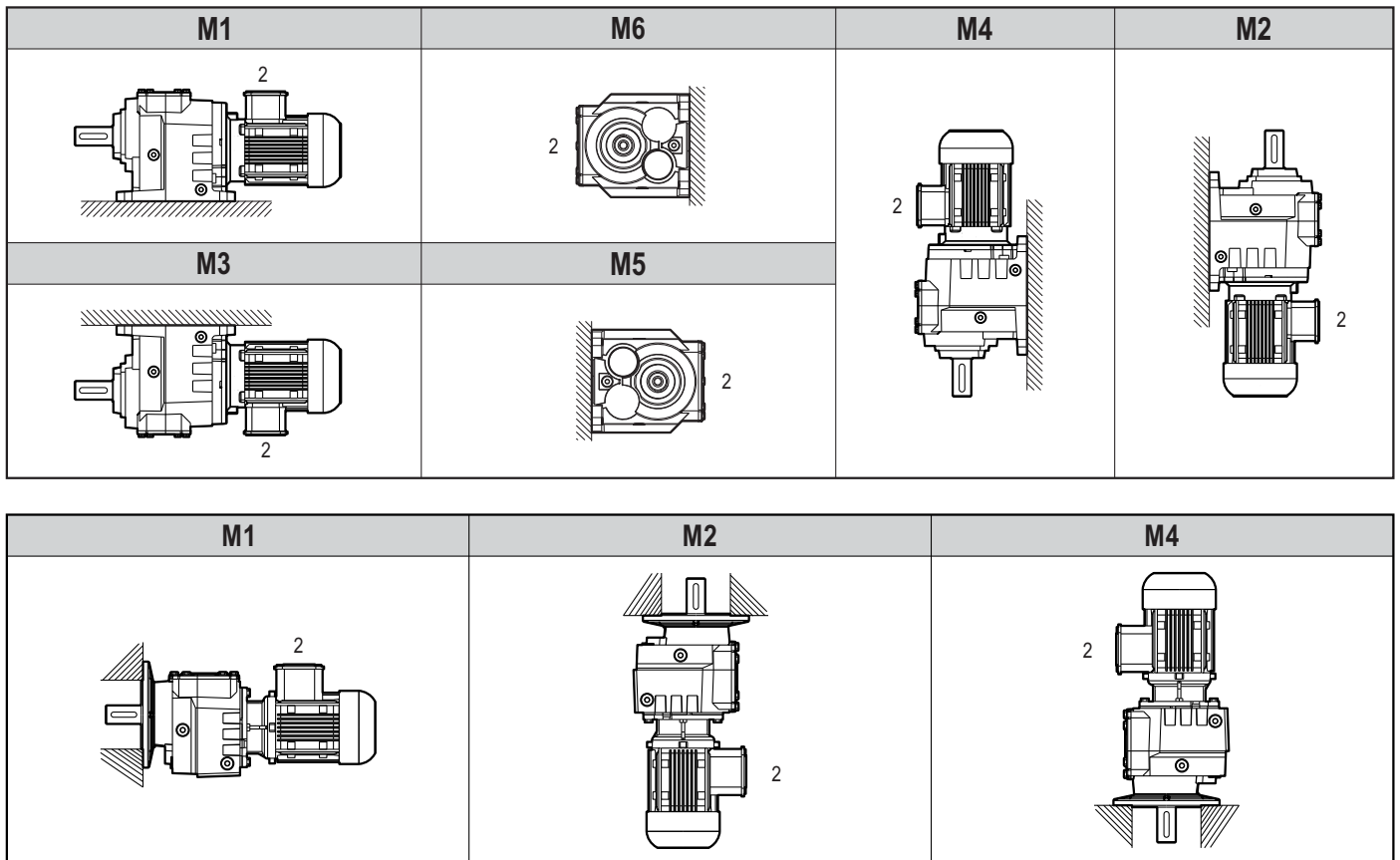

Klemmenkastenlage
Position of terminal box
Posizione morsetteria
Position du bornier
Posición caja de bornes

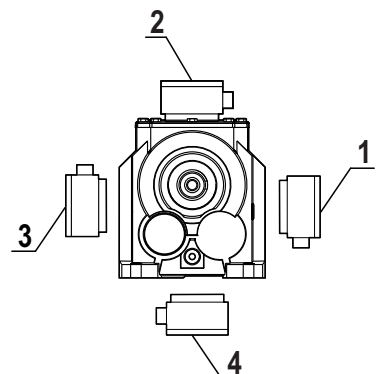
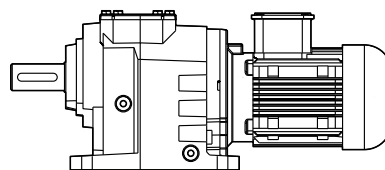
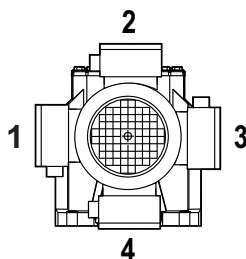

DE MODULARES BAUKASTENSYSTEM

EN MODULARITY

IT MODULARITÀ

FR MODULARITÉ

ES MODULARIDAD

Serie in Grauguss / Grey cast iron series / Serie aus GG. / Série en fonte grise / Serie en fundición gris

A / F...PAM 100

- Ausführungen zum Anbau von PAM - Motoren.
- Fitted for motor coupling version (PAM).
- Versione con predisposizione per attacco motore PAM.
- Version avec prédisposition pour moteur PAM.
- Versión motorreductor (PAM).

A / F...100L/4A

- Ausführungen mit Kompaktelektromotoren.
- Compact electric motor versions.
- Versioni con motore elettrico compatto.
- Version avec moteur électrique compact.
- Versión motorreductor compacto.

A / F...W

- Ausführungen mit Antriebsvollwelle.
- Input shaft versions.
- Versioni con albero maschio in ingresso.
- Version avec arbre en entrée.
- Versión con eje macho de entrada.

A / F...IEC 100

- Die Verbindung Motor Getriebe erfolgt über Kupplung.
- Fitted for motor mounting with flexible coupling.
- Predisposto per attacco motore con giunto.
- Prédisposé pour montage moteur avec joint.
- Predisposto para montaje motor con acoplamiento.

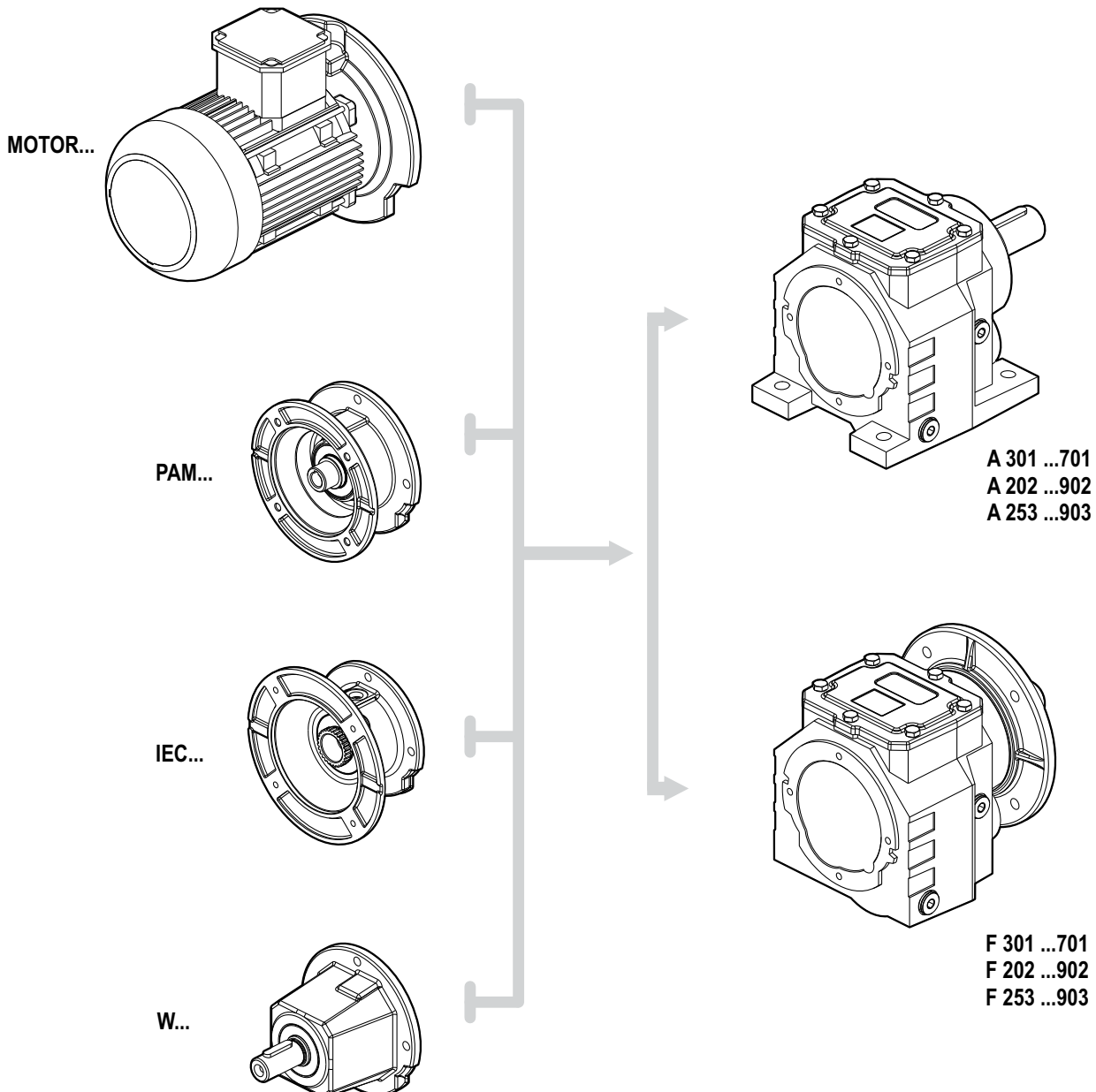





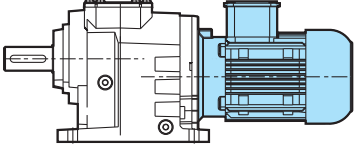
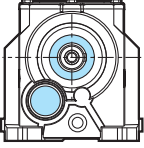
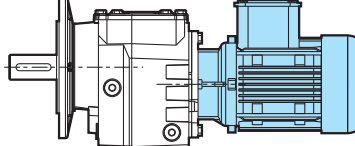
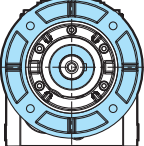
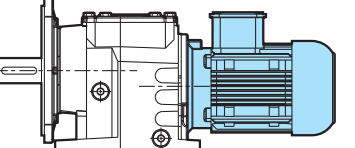

DE PRODUKTE
FR PRODUITS

EN PRODUCTS
ES PRODUCTOS

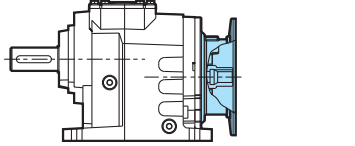
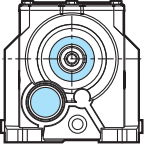
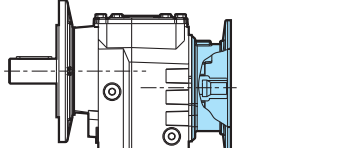
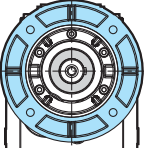
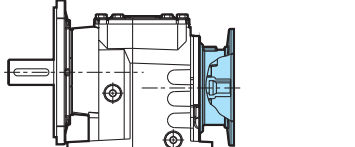
IT PRODOTTI

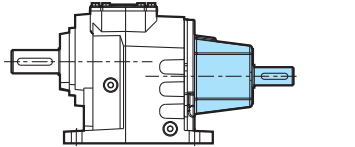
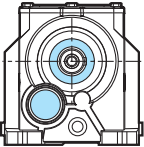
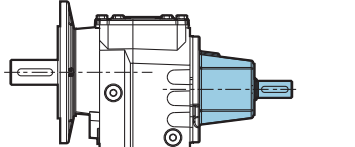
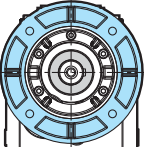
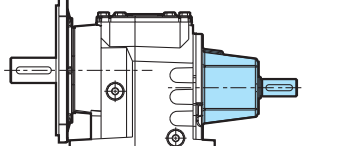
202 - 202 G - 252, 253 - 301, 302, 303 - 351, 352, 353 - 401, 402, 403 - 501, 502, 503 - 601, 602, 603 - 701, 702, 703 - 902, 903

		<p>A... / MOTOR Fußbefestigung Foot mounting Fissaggio piede Fixation à pattes Fijación por patas</p>
		<p>F... / MOTOR Flanschbefestigung Flange mounting Fissaggio flangia Fixation à bride Fijación por brida</p>
		<p>AF... / MOTOR Fuß-Flanschbefestigung Foot-flange mounting Fissaggio piede-flangia Fixation à paaes et bride Fijación patas-brida</p>
		<p>A... / PAM Fußbefestigung Foot mounting Fissaggio piede Fixation à pattes Fijación por patas</p>
		<p>F... / PAM Flanschbefestigung Flange mounting Fissaggio flangia Fixation à bride Fijación por brida</p>
		<p>AF... / PAM Fuß-Flanschbefestigung Foot-flange mounting Fissaggio piede-flangia Fixation à paaes et bride Fijación patas-brida</p>
		<p>A... / W Fußbefestigung Foot mounting Fissaggio piede Fixation à pattes Fijación por patas</p>
		<p>F... / W Flanschbefestigung Flange mounting Fissaggio flangia Fixation à bride Fijación por brida</p>
		<p>AF... / W Fuß-Flanschbefestigung Foot-flange mounting Fissaggio piede-flangia Fixation à paaes et bride Fijación patas-brida</p>

DE BEISPIEL BESTELLBESCHREIBUNG

EN EXAMPLE FOR ORDERING

IT ESEMPIO DI ORDINAZIONE

FR EXEMPLE DE COMMANDE

ES EJEMPLO ORDEN DE COMPRA

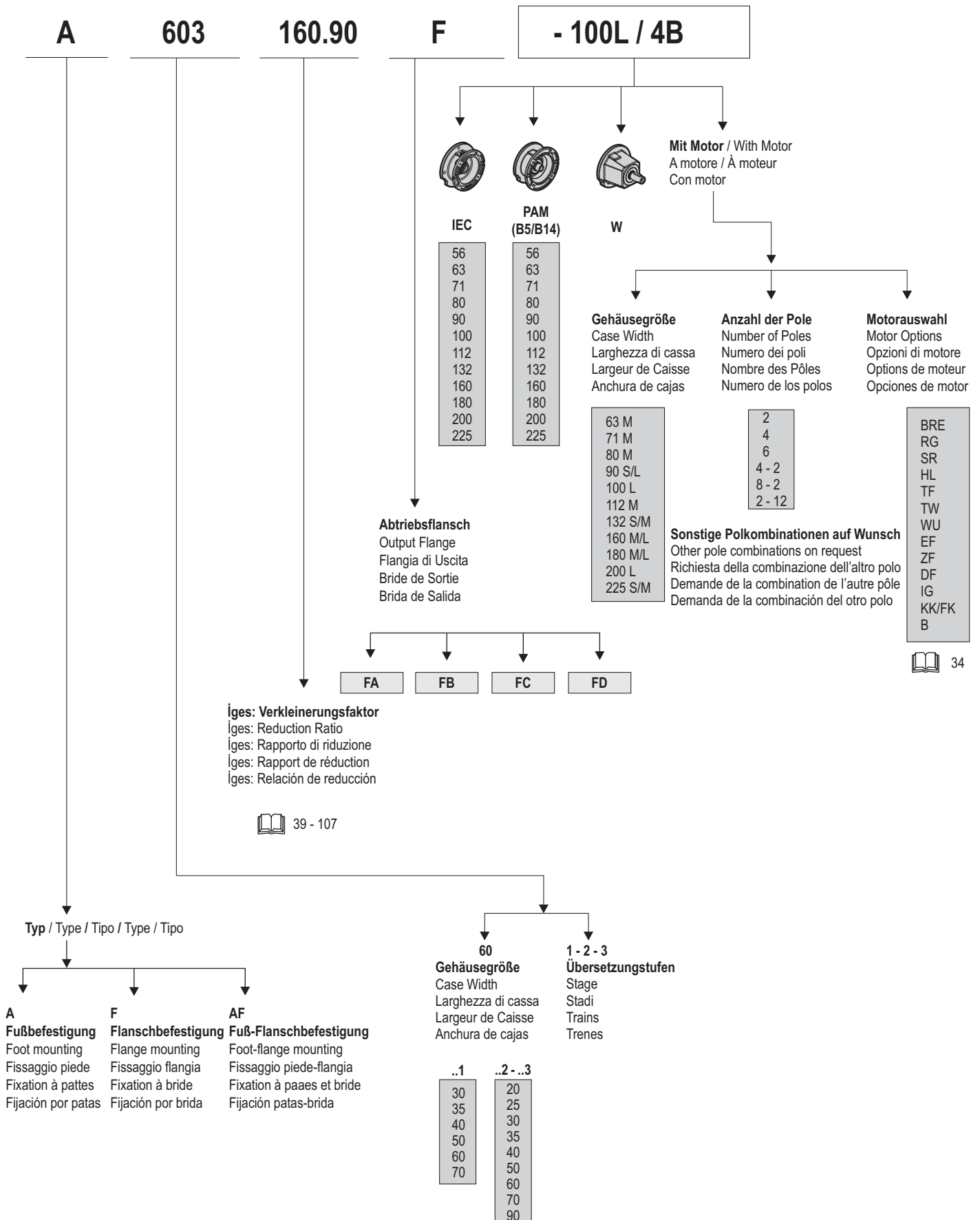

DE	BEZEICHNUNG	EN	DESIGNATION	IT	DESIGNAZIONE
FR	DÉSIGNATION	ES	DESIGNACIÓN		

A / F

A / F	Kompakter Stirnradgetriebemotor (mit Motor geliefert) Compact geared motor with helical gears (supplied complete with motor) Motoriduttore ad ingranaggi cilindrici compatto (fornito completo di motore) Motorréducteur à engrenages cylindriques compact (livré avec moteur) Motorreductor de engranajes cilíndricos compacto (motor y reductor compacto)		
252	Baugröße 25 - 2 Übersetzungsstufen - Ausführung in Grauguss Size 25, 2 reduction stages, cast iron series Grandezza 25, 2 stadi di riduzione, serie in ghisa Grandeur 25, 2 trains d'engrenages, série en fonte Tamaño 25, 2 trenes de engranajes, gama de fundición		
FA - FB FC - FD	Abtriebsflansch Output flange Flangia di uscita Bride de sortie Brida de salida		
44.7	Übersetzungsverhältnis Reduction ratio Rapporto di riduzione Rapport de réduction Relación de reducción		
M1	Einbaulage Mounting position Posizione di piazzamento Position de montage Posición de montaje		
Abmessungen Antriebsseitig / Input dimensions / Dimensioni di entrata / Dimensions d'entrée / Dimensiones de entrada			
PAM	Für Motoranbau vorbereitet Fitted for motor coupling Predisposto per attacco motore Prédisposé pour montage moteur standard Predisuesto para montaje motor		
160	Motorflansch - Durchmesser Motor flange diameter Diametro flangia motore Diamètre bride moteur Diámetro brida motor	14	Motorwellen - Durchmesser Drive - shaft diameter Diametro albero motore Diamètre arbre moteur Diámetro eje motor
Abmessungen abtriebsseitig / Output dimensions / Dimensioni di uscita / Dimensions de sortie / Dimensiones de salida			
200	Durchmesser Abtriebsflansch Output flange diameter Diametro flangia uscita Diamètre de la bride de sortie Diámetro brida de salida	25	Durchmesser abtriebswelle Output shaft diameter Diametro albero uscita Diamètre de l'arbre de sortie Diámetro eje de salida

DE	NOMENKLATUR	EN	NOMENCLATURE	IT	NOMENCLATURA
FR	NOMENCLATURE	ES	NOMENCLATURA		

<p>Eingabeoptionen Input Options Opzioni di ingresso Options d'entrée Opciones de entrada</p>	<p>W = Ausführungen mit antriebsvollwelle / Input shaft versions / Versioni con albero maschio in ingresso / Version avec arbre en entrée / Versión con eje macho de entrada.</p> <p>IEC = Die Verbindung Motor Getriebe erfolgt über Kupplung / Fitted for motor mounting with flexible coupling. / Predisposto per attacco motore con giunto. / Prêdisposé pour montage moteur avec joint. / Predispuosto para montaje motor con acoplamiento.</p> <p>PAM = Für Motoranbau vorbereitet / Fitted for motor coupling / Predisposto per attacco motore / Prêdisposé pour montage moteur standard / Predispuosto para montaje motor</p> <p>T = Turbokupplung / Turbo coupling / Turbogiunto / Coupleur hydraulique / Turboacoplador</p>
<p>Motor Motor Motore Moteur Motor</p>	<p>Drehstrommotor Motorgröße 63 - 225 / Three phase motor Motor size 63 - 225 / Motori trifase, Grandezze 63 - 225 / Motore thriphasé, taille moteur 63 - 225 / Motores trifásicos, Tamaño de carcassas 63 - 225</p>
<p>Anzahl der Pole Number of Poles Numero dei poli Nombre des Pôles Numero de los polos</p>	<p>2 = 2 Pole / 2 Poles / 2 Poli / 2 Pôles / 2 Polos</p> <p>4 = 4 Pole / 4 Poles / 4 Poli / 4 Pôles / 4 Polos</p> <p>6 = 6 Pole / 6 Poles / 6 Poli / 6 Pôles / 6 Polos</p> <p>Sonstige Polkombinationen auf Wunsch / Other pole combinations on request / Richiesta della combinazione dell'altro polo / Demande de la combinaison de l'autre pôle / Demanda de la combinación del otro polo</p>
<p>Motorauswahl Motor Options Opzioni di motore Options de moteur Opciones de motor</p>	<p>BRE = Mit Bremsen / With brake / Freno / avec frein / Freno</p> <p>EF = Separate Lüfter, Einphasig / Separate fan, single phase / Ventilatore separato, monofase / Ventilateur séparé, une phase / Ventilador por separado de una sola fase</p> <p>ZF = Separate Lüfter, Zweiphasig / Separate fan, double phase / Ventilatore separato, doppia fase Ventilateur séparé, double-phase / Ventilador por separado, de doble fase</p> <p>DF = Separate Lüfter, Drei-Phasen / Separate fan, three phase / Ventilatore separato, trifase / Ventilateur séparé, trois phases / Ventilador por separado, tres de fase</p> <p>IG = Mit Encoder / With encoder / Con encoder / avec codeur / con codificador</p> <p>KK/FK = Mit Kupplung / With clutches / Con frizioni / embrayage / embrague</p> <p>SR = Staubsichere Bremse / Brake dust - proof / Freno a prova di polvere / Frein à l'épreuve de la poussière / De frenos a prueba de polvo</p> <p>TF = Thermistor / Thermistor / Termistore / Thermistance / Termistor</p> <p>RG = Gegen Korrosion geschützte Bremse / Brake corrosion - protected / Freno resistente alla corrosione / Frein à la corrosion protégées / Freno protegida contra la corrosión</p> <p>WU = Sanftanlauf-Rotor / Soft start rotor / Soft start rotore / Démarrage en douceur du rotor Soft desde el rotor</p> <p>B = Rücklaufsperr / Backstop / Bloccato contro il ritorno / Verrouillé contre le retour Bloqueado en contra de devolución</p> <p>TW = Temperatursicherung / Thermal trip / Un sensibile al calore / A sensible à la chaleur / Un sensible al calor</p> <p>HL = Handbremsmotoren / Brake motor with hand release / Moteur autofrenante mano / Moteur de frein à main / motores freno manuales</p>

DE ZUBEHÖR
FR ACCESSOIRES

EN ACCESSORIES
ES ACCESORIOS

IT ACCESSORI

1-3 Übersetzungsstufen / 1-3 Stage /
1-3 Stadi / 1-3 Trains / 1-3 Trenes



Ausgangseite / Output side /
Lato uscita / Côté sortie / Lado de salida

2 Übersetzungsstufen / 2 Stage /
2 Stadi / 2 Trains / 2 Trenes



Ausgangseite / Output side /
Lato uscita / Côté sortie / Lado de salida

Rücklaufsperre

Das Getriebe ist mit Rücklaufsperre auf der Antriebswelle erhältlich. Die Rücklaufsperre verhindert die Rotation in die falsche Drehrichtung. Entsprechend der Größe ist sie im Antriebsflansch oder dem Motor integriert. Wichtig ist die Angabe der gewünschten Abtriebsdrehrichtung.

Backstop device

The gear reducer can be supplied with backstop device on input shaft. Backstop device allows output shaft rotation in only one sense of direction; according to the size, it is available in the input flange or in the motor with the same dimensions. It is important to specify the required sense of direction on the order.

Dispositivo antiretro

Il riduttore può essere fornito munito di dispositivo antiretro sull'asse veloce. L'antiretro permette la rotazione degli alberi in un solo senso, a seconda della grandezza è disponibile nella flangia PAM oppure nel motore, senza ingombri aggiuntivi. E' molto importante, in fase di ordine, specificare il senso di rotazione richiesto.

Système antidéviure

Le réducteur de vitesse peut être fourni avec le dispositif antiretour sur l'axe d'entrée. Le dispositif anti retour permet la rotation des arbres de sortie dans un seul sens; selon la taille, il est disponible dans la bride d'entrée ou dans le moteur avec les mêmes dimensions. Il est important de spécifier le sens de la direction demandé sur l'ordre.

Dispositivo antirretorno

El reductor puede suministrarse con un dispositivo antirretorno en el eje veloz. El antirretorno permite la rotación de los ejes en un solo sentido, según el tamaño está disponible en la brida PAM o en el motor, sin incremento de dimensiones. Es muy importante especificar en el pedido el sentido de rotación requerido.

Motor	063	071	080	090	100 - 112	132	160	180	200	225
Größe Size Grandezza Taille Tamaño	140x11	160x14	200x19	200x24	250x28	300x38	350x42	350x48	400x55	450x60
202	B5/B14	B5/B14								
202 G	B5/B14	B5/B14	B5/B14	B5/B14						
252		B5/B14	B5/B14	B5/B14	B5/B14					
253	B5/B14	B5/B14	B5/B14	B5/B14						
301		B5/B14	B5/B14	B5/B14						
302		B5/B14	B5/B14	B5/B14	B5/B14					
303	B5/B14	B5/B14	B5/B14	B5/B14						
351		B5/B14	B5/B14	B5/B14	B5/B14					
352		B5/B14	B5/B14	B5/B14	B5/B14					
353	B5/B14	B5/B14	B5/B14	B5/B14						
401			B5/B14	B5/B14	B5/B14					
402			B5/B14	B5/B14	B5/B14	B5/B14				
403		B5/B14	B5/B14	B5/B14	B5/B14					
501			B5/B14	B5/B14	B5/B14	B5/B14				
502			B5/B14	B5/B14	B5/B14	B5/B14	B5			
503			B5/B14	B5/B14	B5/B14	B5/B14				
601					B5/B14	B5/B14	B5	B5		
602					B5/B14	B5/B14	B5	B5		
603				B5/B14	B5/B14	B5/B14	B5			
701						B5/B14	B5	B5	B5	
702						B5/B14	B5	B5	B5	
703					B5/B14	B5/B14	B5	B5	B5	
902							B5	B5	B5	B5
903						B5/B14	B5	B5	B5	



A large area of the page is filled with horizontal dotted lines, providing a template for writing or drawing.



A series of horizontal dotted lines spanning the width of the page, intended for writing or drawing.

Auswahltabellen der
Getriebemotoren

Selection Tables of
Gearedmotors

Tabelle di selezione dei
motoriduttori

Tables de Gearedmotors de
sélection

Tablas de selección de
gearedmotors

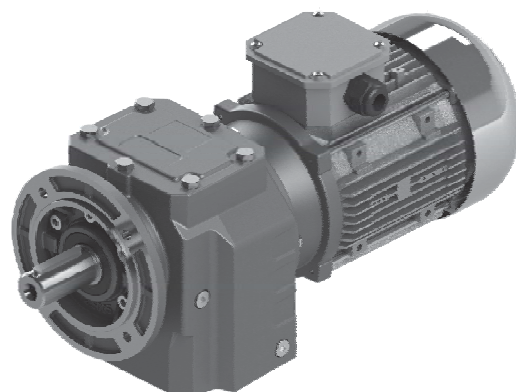
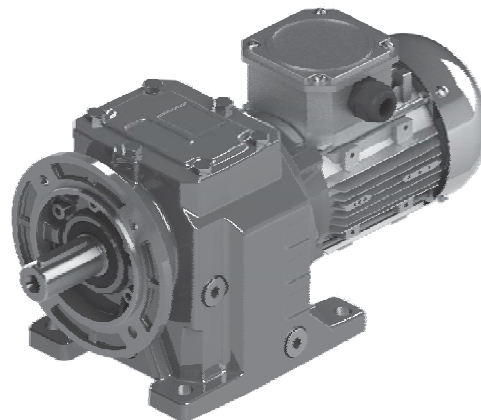
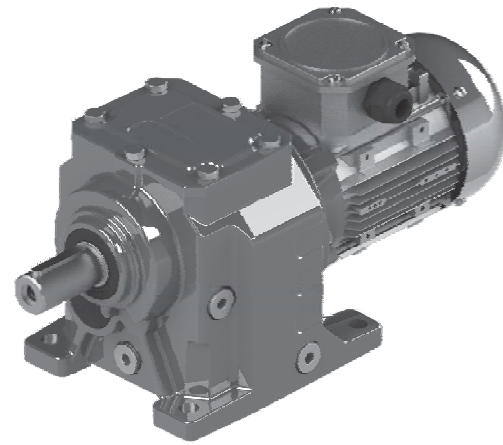

A/F

A/F 301 ... 701

A/F 202 ... 902

A/F 253 ... 903

DE TECHNISCHE BESCHREIBUNGEN

EN TECHNICAL DESCRIPTIONS

IT DESCRIZIONI TECNICHE

FR DESCRIPTIONS TECHNIQUES

ES DESCRIPCIONES TECNICAS

Aufbau der Leistungstafeln für Getriebemotor

Notify about performance tables for Geared motor.

Notificare sulle tabelle di performance per i motoriduttori

Aviser sur les tableaux de performance pour le motoréducteur

Notificar sobre la tabla de performance para los motoreductores.

1.10 kW →

Getriebe Motorleistung

Gear unit motor power
Potenza motore riduttore
Potencia del motor del reductor
Réducteur puissance du moteur

Motornennleistung

Rated motor power
Potenza nominale del motore
Puissance nominale du moteur
Potencia nominal del motor

Servicefaktor

Service factor
Factor de servicio
Fattore di servizio
Facteur de service

Verkleinerungsfaktor

Reduction ratio
Rapporto di riduzione
Rapport de réduction
Relación de reducción

P_1 [kW]	n_2 [Min ⁻¹]	M_2 [Nm]	f_B	i_{ges}	F_{R2} [kN]	Typ / Type / Tipo / Type / Tipo	Kg ~	 mm
1.10	6.3	1559	1.2	222.59	18.0	A503 - 90S/4A F503 - 90S/4A	60	130
	7.2	1365	1.3	194.86	18.0			
	7.9	1253	1.4	178.98	18.0			
	8.7	1136	1.6	162.21	18.0			
	9.1	1082	1.7	154.52	18.0			
	9.9	994	1.8	142.00	18.0			
	11.3	870	2.1	124.25	18.0			
	12.5	789	2.3	112.61	18.0			
	14.4	685	2.6	97.80	18.0			

Abtriebsdrehzahl
Output speed
Vitesse de sortie
Velocità di uscita
Velocidad de salida

Abtriebsdrehmoment

Output torque
Coppia di uscita
Par de salida
Couple de sortie



Zulässige Radialkraft
Permissible radial force
Force radiale admissible
Fuerza radial admisible
Forza radiale ammessa



Getriebe Motortyp



Gear unit motor type
Réducteur type de moteur
Reductor tipo de motor
Riduttore tipo di motore



Zeichnungsseite
Drawing page
Pagina di disegno
Page de dessin
Pagina de diseño



P₁ [kW]	n₂ [Min ⁻¹]	M₂ [Nm]	f_B	i_{ges}	F_R [kN]	Typ / Type / Tipo / Type / Tipo	kg ~	mm				
0.09	3.7	221	0.9	245.76	5.5	A253 - 63M/6 F253 - 63M/6	15	114				
	4.6	177	1.1	197.21	5.5							
	5.0	160	1.2	178.56	5.5							
	6.3	129	1.6	143.29	5.5							
	7.3	111	1.8	123.58	5.5							
	8.3	97	2.1	108.02	5.5							
	9.1	89	2.2	99.17	5.5							
	12.0	67	3.0	74.76	5.5							
	13.5	60	3.3	66.56	5.5							
0.12	21.5	53	0.9	63.59	2.5	A202 - 63M/4A F202 - 63M/4A	7	110				
	24.8	46	1.1	55.03	2.5							
	27.8	41	1.1	49.05	2.5							
	32.3	35	1.4	42.20	2.5							
	37.4	31	1.8	36.45	2.5							
	42.1	27	2.0	32.41	2.5							
	49.2	23	2.3	27.75	2.5							
	55.1	21	2.6	24.78	2.5							
	61.3	19	2.9	22.26	2.5							
	63.9	18	3.1	21.36	2.5							
	71.0	16	3.4	19.23	2.5							
	78.6	15	3.8	17.37	2.5							
	86.7	13	4.2	15.75	2.5							
	94.7	12	4.2	14.42	2.5							
	103.2	11	4.2	13.23	2.5							
	118.5	10	5.2	11.52	2.5							
	136.1	8	6.5	10.03	2.5							
	152.9	7	7.3	8.93	2.5							
	170.0	7	8.2	8.03	2.5							
	189.3	6	9.1	7.21	2.5							
	208.4	5	9.6	6.55	2.5							
	228.3	5	11.0	5.98	2.5							
	248.6	5	11.9	5.49	2.5							
	256.1	4	12.3	5.33	2.5							
	285.0	4	13.2	4.79	2.5							
	318.2	4	13.9	4.29	2.5							
	350.0	3	13.7	3.90	2.5							
	383.4	3	16.1	3.56	2.5							
	418.7	3	16.8	3.26	2.5							
	459.6	2	16.9	2.97	2.5							
	482.3	2	16.8	2.83	2.5							
	535.3	2	17.1	2.55	2.5							
	590.9	2	16.8	2.31	2.5							
	643.9	2	16.8	2.12	2.5							
		16.8	68	1.2	81.41				2.8	A 202 G - 63M/4A F 202 G - 63M/4A	9	112
		19.5	59	1.2	70.05				2.8			
		21.9	52	1.2	62.38				2.8			
		25.3	45	1.9	54.05				2.8			
		29.4	39	2.2	46.41				2.8			
		33.0	35	2.4	41.38				2.8			
		35.3	33	2.6	38.72				2.8			
	39.5	29	3.0	34.55	2.8							
	5.6	194	1.0	245.76	5.5	A253 - 63M/4A F253 - 63M/4A	15	114				
	6.9	156	1.3	197.21	5.5							
	7.6	141	1.4	178.56	5.5							
	9.5	113	1.8	143.29	5.5							
	11.0	98	2.1	123.58	5.5							
	12.6	85	2.3	108.02	5.5							
	13.8	78	2.6	99.17	5.5							
	18.3	59	3.4	74.76	5.5							
20.5	53	3.8	66.56	5.5								
	4.8	222	0.9	178.56	5.5	A253 - 63M/6B F253 - 63M/6B	15	114				
	6.0	178	1.1	143.29	5.5							
	7.0	154	1.3	123.58	5.5							
	8.0	135	1.5	108.02	5.5							
	8.7	124	1.6	99.17	5.5							
	11.6	93	2.1	74.76	5.5							
	13.0	83	2.4	66.56	5.5							
	16.2	67	3.0	53.41	5.5							



P_1 [kW]	n_2 [Min ⁻¹]	M_2 [Nm]	f_B	i_{ges}	F_R [kN]	Typ / Type / Tipo / Type / Tipo	 Kg	 mm
0.12	4.8	223	1.3	282.17	6.6	A303 - 63M/4A F303 - 63M/4A	18	118
	6.0	180	1.7	227.56	6.6			
	6.7	162	1.9	205.01	6.6			
	8.3	130	2.3	165.33	6.6			
	9.6	112	2.7	141.89	6.6			
	10.9	99	3.0	125.65	6.6			
	11.9	90	3.3	114.42	6.6			
	3.1	351	0.9	282.17	6.6	A303 - 63M/6B F303 - 63M/6B	18	118
	3.8	283	1.1	227.56	6.6			
	4.2	255	1.2	205.01	6.6			
	5.2	206	1.5	165.33	6.6			
	6.1	177	1.7	141.89	6.6			
6.9	156	1.9	125.65	6.6				
7.6	142	2.1	114.42	6.6				
9.9	108	2.8	86.96	6.6				
11.3	95	3.2	76.42	6.6				
5.1	212	2.4	268.00	8.0	A353 - 63M/4A F353 - 63M/4A	23	122	
6.3	171	2.9	216.67	8.0				
7.0	154	3.3	194.72	8.0				
3.2	334	1.5	268.00	8.0	A353 - 63M/6B F353 - 63M/6B	23	122	
4.0	270	1.9	216.67	8.0				
4.4	242	2.1	194.72	8.0				
5.5	196	2.6	157.42	8.0				
6.4	168	3.0	134.76	8.0				
7.9	136	3.7	108.95	8.0				
6.3	214	0.9	143.29	5.5				A 253 - 63M/6C F 253 - 63M/6C
7.3	185	1.1	123.58	5.5				
8.3	162	1.2	108.02	5.5				
9.1	148	1.3	99.17	5.5				
12.0	112	1.8	74.76	5.5				
13.5	100	2.0	66.56	5.5				
16.9	80	2.5	53.41	5.5				
4.0	340	0.9	227.56	6.6	A 303 - 63M/6C F 303 - 63M/6C	18	118	
4.4	307	1.0	205.01	6.6				
5.4	247	1.2	165.33	6.6				
6.3	212	1.4	141.89	6.6				
7.2	188	1.6	125.65	6.6				
7.9	171	1.8	114.42	6.6				
10.3	130	2.3	86.96	6.6				
11.8	114	2.6	76.42	6.6				
14.6	92	3.3	61.63	6.6				
3.4	401	1.2	268.00	8.0	A 353 - 63M/6C F 353 - 63M/6C	23	122	
4.2	324	1.5	216.67	8.0				
4.6	291	1.7	194.72	8.0				
5.7	236	2.1	157.42	8.0				
6.7	202	2.5	134.76	8.0				
8.3	163	3.1	108.95	8.0				
9.9	135	3.7	90.51	8.0				
0.18	32.7	53	1.0	42.20	2.5	A202 - 63M/4B F202 - 63M/4B	8	110
	37.9	45	1.2	36.45	2.5			
	42.6	40	1.4	32.41	2.5			
	49.7	35	1.6	27.75	2.5			
	55.7	31	1.8	24.78	2.5			
	62.0	28	2.0	22.26	2.5			
	64.6	27	2.1	21.36	2.5			
	71.8	24	2.3	19.23	2.5			
	79.4	22	2.5	17.37	2.5			
	87.6	20	2.8	15.75	2.5			
	95.7	18	2.8	14.42	2.5			
	104.3	16	2.9	13.23	2.5			
	119.8	14	3.5	11.52	2.5			
	137.6	12	4.4	10.03	2.5			
	154.5	11	4.9	8.93	2.5			
	171.9	10	5.5	8.03	2.5			
	191.4	9	6.1	7.21	2.5			
	210.7	8	6.5	6.55	2.5			
230.8	7	7.4	5.98	2.5				
251.4	7	8.0	5.49	2.5				



P₁ [kW]	n₂ [Min ⁻¹]	M₂ [Nm]	f_B	i_{ges}	F_R [kN]	Typ / Type / Tipo / Type / Tipo	kg 	mm 
0.18	258.9	7	8.3	5.33	2.5	A202 - 63M/4B F202 - 63M/4B	8	110
	288.1	6	8.9	4.79	2.5			
	321.7	5	9.4	4.29	2.5			
	353.8	5	9.3	3.90	2.5			
	387.6	4	10.8	3.56	2.5			
	423.3	4	11.2	3.26	2.5			
	464.6	4	11.4	2.97	2.5			
	487.6	4	11.2	2.83	2.5			
	541.2	3	11.6	2.55	2.5			
	597.4	3	11.3	2.31	2.5			
650.9	3	11.4	2.12	2.5				
	17.0	101	0.8	81.41	2.8	A 202 G - 63M/4B F 202 G - 63M/4B	9	112
	19.7	87	0.8	70.05	2.8			
	22.1	78	0.8	62.38	2.8			
	25.5	67	1.3	54.05	2.8			
	29.7	58	1.5	46.41	2.8			
	33.3	52	1.6	41.38	2.8			
	35.6	48	1.8	38.72	2.8			
	39.9	43	2.0	34.55	2.8			
	44.5	39	2.4	31.03	2.8			
	49.9	34	2.7	27.66	2.8			
55.6	31	3.0	24.83	2.8				
	18.8	88	2.3	47.93	5.5	A252 - 71M/6A F252 - 71M/6A	19	114
	21.4	77	2.6	42.00	5.5			
	23.4	71	2.8	38.46	5.5			
	27.0	61	3.3	33.38	5.5			
	29.9	55	3.6	30.15	5.5			
	11.4	142	1.1	245.76	5.5	A253 - 63M/2A F253 - 63M/2A	15	114
	14.2	114	1.4	197.21	5.5			
	15.7	103	1.5	178.56	5.5			
	19.5	83	1.9	143.29	5.5			
	22.7	71	2.2	123.58	5.5			
	25.9	62	2.5	108.02	5.5			
	28.2	57	2.7	99.17	5.5			
	37.5	43	3.6	74.76	5.5			
	7.7	209	1.0	178.56	5.5	A253 - 63M/4B F253 - 63M/4B	15	114
	9.6	168	1.2	143.29	5.5			
	11.2	145	1.4	123.58	5.5			
	12.8	126	1.6	108.02	5.5			
	13.9	116	1.7	99.17	5.5			
	18.5	88	2.3	74.76	5.5			
	20.7	78	2.6	66.56	5.5			
	25.8	63	3.2	53.41	5.5			
	7.3	222	0.9	123.58	5.5	A253 - 71M/6A F253 - 71M/6A	19	114
	8.3	194	1.0	108.02	5.5			
	9.1	178	1.1	99.17	5.5			
	12.0	134	1.5	74.76	5.5			
	13.5	120	1.7	66.56	5.5			
	16.9	96	2.1	53.41	5.5			
	101.4	16	3.3	8.88	1.0	A301 - 71M/6A F301 - 71M/6A	18	116
	115.7	14	3.5	7.78	1.0			
	16.4	101	2.8	55.03	6.6	A302 - 71M/6A F302 - 71M/6A	22	118
	18.7	88	3.2	48.22	6.6			
	20.3	81	3.4	44.38	6.6			
	9.9	163	1.4	282.17	6.6	A303 - 63M/2A F303 - 63M/2A	18	118
	12.3	131	1.7	227.56	6.6			
	13.7	118	1.9	205.01	6.6			
	16.9	95	2.4	165.33	6.6			
	19.7	82	2.7	141.89	6.6			
	22.3	73	3.1	125.65	6.6			
	24.5	66	3.4	114.42	6.6			



P₁ [kW]	n₂ [Min ⁻¹]	M₂ [Nm]	f_B	i_{ges}	F_R [kN]	Typ / Type / Tipo / Type / Tipo	kg 	mm 		
0.18	4.9	330	0.9	282.17	6.6	A303 - 63M/4B F303 - 63M/4B	18	118		
	6.1	266	1.1	227.56	6.6					
	6.7	240	1.2	205.01	6.6					
	8.3	194	1.5	165.33	6.6					
	9.7	166	1.8	141.89	6.6					
	11.0	147	2.0	125.65	6.6					
	12.1	134	2.2	114.42	6.6					
	15.9	102	2.9	86.96	6.6					
	18.1	89	3.4	76.42	6.6					
		5.4	297	1.0	165.33	6.6	A303 - 71M/6A F303 - 71M/6A	22	118	
		6.3	255	1.2	141.89	6.6				
		7.2	226	1.3	125.65	6.6				
		7.9	205	1.5	114.42	6.6				
		10.3	156	1.9	86.96	6.6				
		11.8	137	2.2	76.42	6.6				
		14.6	111	2.7	61.63	6.6				
			10.4	155	2.4	268.00	8.0	A353 - 63M/2A F353 - 63M/2A	23	122
			12.9	125	3.0	216.67	8.0			
			14.4	112	3.3	194.72	8.0			
		5.1	314	1.6	268.00	8.0	A353 - 63M/4B F353 - 63M/4B	23	122	
		6.4	254	2.0	216.67	8.0				
		7.1	228	2.2	194.72	8.0				
		8.8	184	2.7	157.42	8.0				
		10.2	158	3.2	134.76	8.0				
		12.7	128	3.9	108.95	8.0				
		3.4	481	1.0	268.00	8.0	A353 - 71M/6A F353 - 71M/6A	27	122	
		4.2	389	1.3	216.67	8.0				
		4.6	350	1.4	194.72	8.0				
5.7		283	1.8	157.42	8.0					
6.7		242	2.1	134.76	8.0					
8.3		196	2.6	108.95	8.0					
9.9		163	3.1	90.51	8.0					
12.4		130	3.8	72.58	8.0					
	3.4	481	1.8	267.75	12.0	A 403 - 71M/6A F 403 - 71M/6A	37	126		
	3.8	421	2.0	234.50	12.0					
	4.2	386	2.2	215.01	12.0					
	4.8	334	2.5	186.14	12.0					
	5.3	306	2.8	170.55	12.0					
	6.0	268	3.2	149.47	12.0					
	6.6	243	3.5	135.37	12.0					
0.22	9.8	202	1.0	143.29	5.5	A253 - 63M/4D F253 - 63M/4D	16	114		
	11.3	174	1.1	123.58	5.5					
	13.0	152	1.3	108.02	5.5					
	14.1	140	1.4	99.17	5.5					
	18.7	105	1.9	74.76	5.5					
	21.0	94	2.1	66.56	5.5					
	26.2	75	2.7	53.41	5.5					
		6.2	321	0.9	227.56	6.6	A303 - 63M/4D F303 - 63M/4D	19	118	
		6.8	289	1.0	205.01	6.6				
		8.5	233	1.3	165.33	6.6				
		9.9	200	1.5	141.89	6.6				
		11.1	177	1.7	125.65	6.6				
		12.2	161	1.9	114.42	6.6				
		16.1	123	2.4	86.96	6.6				
		18.3	108	2.8	76.42	6.6				
		22.7	87	3.5	61.63	6.6				
		5.2	378	1.3	268.00	8.0	A353 - 63M/4D F353 - 63M/4D	24	122	
		6.5	306	1.6	216.67	8.0				
		7.2	275	1.8	194.72	8.0				
		8.9	222	2.3	157.42	8.0				
		10.4	190	2.6	134.76	8.0				
		12.8	154	3.3	108.95	8.0				
		15.5	128	3.9	90.51	8.0				



P_1 [kW]	n_2 [Min ⁻¹]	M_2 [Nm]	f_B	i_{ges}	F_R [kN]	Typ / Type / Tipo / Type / Tipo	 Kg ~	 mm			
0.25	260.8	9	6.0	5.33	2.5	A202 - 71M/4A F202 - 71M/4A	8	110			
	290.2	8	6.4	4.79	2.5						
	324.0	7	6.8	4.29	2.5						
	356.4	7	6.7	3.90	2.5						
	390.4	6	7.8	3.56	2.5						
	426.4	6	8.2	3.26	2.5						
	468.0	5	8.2	2.97	2.5						
	491.2	5	8.2	2.83	2.5						
	545.1	4	8.3	2.55	2.5						
	601.7	4	8.2	2.31	2.5						
	655.7	4	8.2	2.12	2.5						
	50.1	48	1.1	27.75	2.5				A202 - 71M/4A F202 - 71M/4A	8	110
	56.1	43	1.3	24.78	2.5						
	62.4	38	1.4	22.26	2.5						
	65.1	37	1.5	21.36	2.5						
	72.3	33	1.7	19.23	2.5						
	80.0	30	1.8	17.37	2.5						
	88.3	27	2.0	15.75	2.5						
	96.4	25	2.1	14.42	2.5						
105.1	23	2.1	13.23	2.5							
120.7	20	2.5	11.52	2.5							
138.6	17	3.2	10.03	2.5							
155.7	15	3.6	8.93	2.5							
173.1	14	4.0	8.03	2.5							
192.8	12	4.4	7.21	2.5							
212.2	11	4.7	6.55	2.5							
232.4	10	5.4	5.98	2.5							
253.2	9	5.8	5.49	2.5							
25.7	93	0.9	54.05	2.8	A 202 G - 71M/4A F 202 G - 71M/4A	11	112				
30.0	80	1.1	46.41	2.8							
33.6	71	1.2	41.38	2.8							
35.9	67	1.3	38.72	2.8							
40.2	59	1.4	34.55	2.8							
44.8	53	1.7	31.03	2.8							
50.3	48	1.9	27.66	2.8							
56.0	43	2.2	24.83	2.8							
61.9	39	2.4	22.44	2.8							
68.3	35	2.4	20.35	2.8							
74.6	32	2.6	18.63	2.8							
29.0	79	2.5	47.93	5.5				A252 - 71M/4A F252 - 71M/4A	18	114	
33.1	69	2.9	42.00	5.5							
36.1	63	3.2	38.46	5.5							
41.6	55	3.6	33.38	5.5							
19.0	121	1.7	47.93	5.5	A252 - 71M/6B F252 - 71M/6B	23	114				
21.7	106	1.9	42.00	5.5							
23.7	97	2.1	38.46	5.5							
27.3	84	2.4	33.38	5.5							
30.2	76	2.6	30.15	5.5							
34.0	67	3.0	26.79	5.5							
37.6	61	3.3	24.19	5.5							
39.5	58	3.4	23.04	5.5							
15.7	143	1.1	178.56	5.5				A253 - 63M/2B F253 - 63M/2B	16	114	
19.5	115	1.4	143.29	5.5							
22.7	99	1.6	123.58	5.5							
25.9	87	1.8	108.02	5.5							
28.2	79	2.0	99.17	5.5							
37.5	60	2.6	74.76	5.5							
42.1	53	2.9	66.56	5.5							
52.4	43	3.6	53.41	5.5							
11.2	200	1.0	123.58	5.5	A/F 253 - 63M/4C A/F 253 - 71M/4A	18	114				
12.9	174	1.1	108.02	5.5							
14.0	160	1.2	99.17	5.5							
18.6	121	1.7	74.76	5.5							
20.9	107	1.9	66.56	5.5							
26.0	86	2.3	53.41	5.5							

P_1 [kW]	n_2 [Min ⁻¹]	M_2 [Nm]	f_B	i_{ges}	F_R [kN]	Typ / Type / Tipo / Type / Tipo	 Kg	 mm
0.25	12.2	184	1.1	74.76	5.5	A253 - 71M/6B F253 - 71M/6B	23	114
	13.7	164	1.2	66.56	5.5			
	17.0	132	1.5	53.41	5.5			
	156.6	15	3.7	8.88	1.0	A301 - 71M/4A F301 - 71M/4A	14	116
	178.7	13	3.9	7.78	1.0			
	102.5	23	2.4	8.88	1.0	A301 - 71M/6B F301 - 71M/6B	19	116
	117.0	20	2.5	7.78	1.0			
	147.2	16	3.2	6.18	1.0			
	163.0	14	3.5	5.58	1.0			
	179.2	13	3.5	5.08	1.0			
	25.3	91	3.1	55.03	6.6	A302 - 71M/4A F302 - 71M/4A	21	118
	28.8	80	3.5	48.22	6.6			
	31.3	73	3.8	44.38	6.6			
	16.5	139	2.0	55.03	6.6	A302 - 71M/6B F302 - 71M/6B	26	118
	18.9	121	2.3	48.22	6.6			
	20.5	112	2.5	44.38	6.6			
	23.7	97	2.9	38.33	6.6			
	26.3	87	3.2	34.62	6.6			
	29.4	78	3.6	30.91	6.6			
	9.9	226	1.0	282.17	6.6			
12.3	182	1.3	227.56	6.6				
13.7	164	1.4	205.01	6.6				
16.9	133	1.7	165.33	6.6				
19.7	114	2.0	141.89	6.6				
22.3	101	2.3	125.65	6.6				
24.5	92	2.5	114.42	6.6				
32.2	70	3.3	86.96	6.6				
36.6	61	3.8	76.42	6.6				
6.8	331	0.9	205.01	6.6	A/F 303 - 63M/4C A/F 303 - 71M/4A	21	118	
8.4	267	1.1	165.33	6.6				
9.8	229	1.3	141.89	6.6				
11.1	203	1.5	125.65	6.6				
12.1	185	1.6	114.42	6.6				
16.0	140	2.1	86.96	6.6				
18.2	123	2.4	76.42	6.6				
22.6	100	3.0	61.63	6.6				
7.2	310	1.0	125.65	6.6	A303 - 71M/6B F303 - 71M/6B	26	118	
8.0	282	1.1	114.42	6.6				
10.5	214	1.4	86.96	6.6				
11.9	188	1.6	76.42	6.6				
14.8	152	2.0	61.63	6.6				
16.0	143	3.4	56.95	8.0	A352 - 71M/6B F352 - 71M/6B	31	122	
10.4	215	1.8	268.00	8.0	A353 - 63M/2B F353 - 63M/2B	24	122	
12.9	174	2.2	216.67	8.0				
14.4	156	2.5	194.72	8.0				
17.8	126	3.1	157.42	8.0				
20.8	108	3.6	134.76	8.0				
5.2	433	1.2	268.00	8.0	A/F 353 - 63M/4C A/F 353 - 71M/4A	26	122	
6.4	350	1.4	216.67	8.0				
7.1	314	1.6	194.72	8.0				
8.8	254	2.0	157.42	8.0				
10.3	218	2.3	134.76	8.0				
12.8	176	2.8	108.95	8.0				
15.4	146	3.4	90.51	8.0				
4.2	534	0.9	216.67	8.0	A353 - 71M/6B F353 - 71M/6B	31	122	
4.7	480	1.0	194.72	8.0				
5.8	388	1.3	157.42	8.0				
6.8	332	1.5	134.76	8.0				
8.4	269	1.9	108.95	8.0				
10.1	223	2.2	90.51	8.0				
12.5	179	2.8	72.58	8.0				
15.5	145	3.5	58.68	8.0				



P_1 [kW]	n_2 [Min ⁻¹]	M_2 [Nm]	f_B	i_{ges}	F_R [kN]	Typ / Type / Tipo / Type / Tipo	 Kg ~	 mm			
0.25	5.2	432	2.0	267.75	12.0	A403 - 71M/4A F403 - 71M/4A	36	126			
	5.9	379	2.2	234.50	12.0						
	6.5	347	2.4	215.01	12.0						
	7.5	301	2.8	186.14	12.0						
	8.2	275	3.1	170.55	12.0						
	9.3	241	3.5	149.47	12.0						
	10.3	219	3.9	135.37	12.0						
	3.4	660	1.3	267.75	12.0				A403 - 71M/6B F403 - 71M/6B	41	126
	3.9	578	1.5	234.50	12.0						
	4.2	530	1.6	215.01	12.0						
	4.9	459	1.9	186.14	12.0						
	5.3	421	2.0	170.55	12.0						
	6.1	369	2.3	149.47	12.0						
	6.7	334	2.5	135.37	12.0						
	7.7	291	2.9	118.13	12.0						
	9.6	234	3.6	94.86	12.0						
	0.37	50.1	71	0.8	27.75	2.5	A202 - 71M/4B F202 - 71M/4B	9	110		
		56.1	63	0.9	24.78	2.5					
62.4		57	1.0	22.26	2.5						
65.1		54	1.0	21.36	2.5						
72.3		49	1.1	19.23	2.5						
80.0		44	1.2	17.37	2.5						
88.3		40	1.4	15.75	2.5						
96.4		37	1.4	14.42	2.5						
105.1		34	1.4	13.23	2.5						
120.7		29	1.7	11.52	2.5						
138.6		25	2.2	10.03	2.5						
155.7		23	2.4	8.93	2.5						
173.1		20	2.7	8.03	2.5						
192.8		18	3.0	7.21	2.5						
212.2		17	3.2	6.55	2.5						
232.4		15	3.6	5.98	2.5						
253.2		14	3.9	5.49	2.5						
260.8		14	4.1	5.33	2.5						
290.2		12	4.4	4.79	2.5						
324.0		11	4.6	4.29	2.5						
356.4		10	4.5	3.90	2.5						
390.4		9	5.3	3.56	2.5						
426.4		8	5.6	3.26	2.5						
468.0		8	5.6	2.97	2.5						
491.2		7	5.6	2.83	2.5						
545.1		6	5.7	2.55	2.5						
601.7		6	5.6	2.31	2.5						
655.7		5	5.6	2.12	2.5						
35.9		98	0.9	38.72	2.8	A 202 G - 71M/4B F 202 G - 71M/4B				11	112
40.2		88	1.0	34.55	2.8						
44.8		79	1.2	31.03	2.8						
50.3		70	1.3	27.66	2.8						
56.0		63	1.5	24.83	2.8						
61.9		57	1.6	22.44	2.8						
68.3		52	1.6	20.35	2.8						
74.6		47	1.8	18.63	2.8						
88.3		40	2.1	15.74	2.8						
102.5		34	2.5	13.56	2.8						
115.0		31	2.8	12.09	2.8						
121.8		29	2.9	11.41	2.8						
128.1		28	3.1	10.85	2.8						
58.4		56	2.7	47.93	5.5		A252 - 71M/2A F252 - 71M/2A	18	114		
66.7		51	2.9	42.00	5.5						
72.8		47	3.2	38.46	5.5						
83.9		40	3.7	33.38	5.5						
29.0		117	1.7	47.93	5.5	A252 - 71M/4B F252 - 71M/4B	20	114			
33.1		102	2.0	42.00	5.5						
36.1		94	2.1	38.46	5.5						
41.6		81	2.5	33.38	5.5						
46.1		74	2.7	30.15	5.5						
51.9		65	3.1	26.79	5.5						
57.5		59	3.4	24.19	5.5						
60.3		56	3.6	23.04	5.5						

P_1 [kW]	n_2 [Min ⁻¹]	M_2 [Nm]	f_B	i_{ges}	F_R [kN]	Typ / Type / Tipo / Type / Tipo	 Kg	 mm			
0.37	19.2	177	1.1	47.93	5.5	A/F 252 - 71M/6 A/F 252 - 80M/6A	21	114			
	21.9	155	1.3	42.00	5.5						
	23.9	142	1.4	38.46	5.5						
	27.6	123	1.6	33.38	5.5						
	30.5	111	1.8	30.15	5.3						
	34.3	99	2.0	26.79	5.0						
	38.0	89	2.2	24.19	4.8						
	39.9	85	2.4	23.04	4.7						
	45.6	74	2.7	20.19	4.4						
	49.8	68	2.9	18.49	4.2						
	54.0	63	3.0	17.05	4.1						
	61.7	55	3.1	14.91	4.1						
	66.0	51	3.3	13.94	3.9						
	76.9	44	3.3	11.97	3.9						
	89.1	38	3.7	10.32	3.7						
	22.7	147	1.1	123.58	5.5	A/F 253 - 63M/2D A/F 253 - 71M/2A	18	114			
	25.9	128	1.2	108.02	5.5						
	28.2	118	1.3	99.17	5.5						
	37.5	89	1.8	74.76	5.5						
	42.1	79	2.0	66.56	5.5						
	52.4	63	2.5	53.41	5.5						
	18.6	179	1.1	74.76	5.5	A253 - 71M/4B F253 - 71M/4B	20	114			
	20.9	159	1.3	66.56	5.5						
	26.0	128	1.6	53.41	5.5						
	17.2	193	1.0	53.41	5.5	A/F 253 - 71M/6 A/F 253 - 80M/6A	21	114			
	315.7	11	3.9	8.87	1.0	A301 - 71M/2A F301 - 71M/2A	14	116			
	156.7	22	2.5	8.87	1.0	A301 - 71M/4B F301 - 71M/4B	17	116			
	178.7	19	2.6	7.78	1.0						
	224.9	15	3.3	6.18	1.0						
	249.0	14	3.6	5.58	1.0						
	273.8	13	3.6	5.08	1.0						
	103.7	33	1.7	8.87	1.0	A301 - 80M/6A F301 - 80M/6A	17	116			
	118.3	29	1.7	7.78	1.0						
	148.9	23	2.2	6.18	1.0						
	164.8	21	2.4	5.58	1.0						
	181.2	19	2.4	5.08	1.0						
	215.6	16	2.8	4.27	1.0						
	252.3	14	3.3	3.65	1.0						
	291.3	12	3.4	3.16	1.0						
	333.1	10	2.9	2.76	1.0						
	355.1	10	3.1	2.59	1.0						
	451.3	8	3.3	2.04	0.9						
	50.9	63	3.4	55.03	6.6	A302 - 71M/2A F302 - 71M/2A	21	118			
	58.1	55	3.8	48.22	6.6						
	25.3	134	2.1	55.03	6.6	A302 - 71M/4B F302 - 71M/4B	24	118			
	28.8	118	2.4	48.22	6.6						
	31.3	108	2.6	44.38	6.6						
	36.3	94	3.0	38.33	6.6						
	40.2	84	3.3	34.62	6.6						
	45.0	75	3.7	30.91	6.6						
	16.7	203	1.4	55.03	6.6	A/F 302 - 71M/6 A/F 302 - 80M/6A	24	118			
	19.1	178	1.6	48.22	6.6						
	20.7	164	1.7	44.38	6.6						
	24.0	141	2.0	38.33	6.6						
	26.6	128	2.2	34.62	6.6						
	29.8	114	2.5	30.91	6.6						
	33.0	103	2.7	27.92	6.6						
	34.8	98	2.7	26.45	6.6						
	39.2	87	3.0	23.49	6.3						
	43.1	79	3.2	21.33	6.1						
	47.7	71	3.5	19.29	5.8						



P_1 [kW]	n_2 [Min ⁻¹]	M_2 [Nm]	f_B	i_{ges}	F_R [kN]	Typ / Type / Tipo / Type / Tipo	 Kg	 mm
0.37	16.9	188	1.2	165.33	6.6	A/F 303 - 63M/2D A/F 303 - 71M/2A	21	118
	19.7	161	1.4	141.89	6.6			
	22.3	143	1.6	125.65	6.6			
	24.5	130	1.7	114.42	6.6			
	32.2	99	2.3	86.96	6.6			
	36.6	87	2.6	76.42	6.6			
	45.4	70	3.2	61.63	6.6			
	11.1	300	1.0	125.65	6.6	A303 - 71M/4B F303 - 71M/4B	23	118
	12.1	273	1.1	114.42	6.6			
	16.0	208	1.4	86.96	6.6			
	18.2	183	1.6	76.42	6.6			
	22.6	147	2.0	61.63	6.6			
	10.6	314	1.0	86.96	6.6	A/F 303 - 71M/6 A/F 303 - 80M/6A	24	118
	12.0	276	1.1	76.42	6.6			
	14.9	223	1.3	61.63	6.6			
	109.8	31	3.2	8.38	2.5	A/F 351 - 71M/6 A/F 351 - 80M/6A	18	120
	125.5	27	3.7	7.33	2.5			
	24.4	139	3.5	56.95	8.0	A352 - 71M/4B F352 - 71M/4B	28	122
	16.2	210	2.3	56.95	8.0	A/F 352 - 71M/6 A/F 352 - 80M/6A	29	122
	18.4	184	2.7	49.88	8.0			
	20.0	170	2.9	46.04	8.0			
	23.2	146	3.4	39.59	8.0			
	10.4	304	1.2	268.00	8.0	A/F 353 - 63M/2D A/F 353 - 71M/2A	26	122
	12.9	246	1.5	216.67	8.0			
	14.4	221	1.7	194.72	8.0			
	17.8	179	2.1	157.42	8.0			
	20.8	153	2.5	134.76	8.0			
	25.7	124	3.0	108.95	8.0			
	30.9	103	3.6	90.51	8.0			
	6.4	518	1.0	216.67	8.0	A353 - 71M/4B F353 - 71M/4B	28	122
	7.1	465	1.1	194.72	8.0			
	8.8	376	1.3	157.42	8.0			
	10.3	322	1.6	134.76	8.0			
	12.8	260	1.9	108.95	8.0			
	15.4	216	2.3	90.51	8.0			
	19.2	173	2.9	72.58	8.0			
	23.7	140	3.6	58.68	8.0			
	6.8	487	1.0	134.76	8.0	A/F 353 - 71M/6 A/F 353 - 80M/6A	29	122
	8.4	393	1.3	108.95	8.0			
	10.2	327	1.5	90.51	8.0			
	12.7	262	1.9	72.58	8.0			
	15.7	212	2.4	58.68	8.0			
10.4	306	2.1	267.75	12.0	A403 - 71M/2A F403 - 71M/2A	36	126	
11.9	266	2.4	234.50	12.0				
13.0	244	2.6	215.01	12.0				
15.0	211	3.0	186.14	12.0				
16.4	194	3.3	170.55	12.0				
18.7	170	3.8	149.47	12.0				
5.2	640	1.3	267.75	12.0	A403 - 71M/4B F403 - 71M/4B	38	126	
5.9	560	1.5	234.50	12.0				
6.5	514	1.7	215.01	12.0				
7.5	445	1.9	186.14	12.0				
8.2	408	2.1	170.55	12.0				
9.3	357	2.4	149.47	12.0				
10.3	323	2.6	135.37	12.0				
11.8	282	3.0	118.13	12.0				
14.7	227	3.7	94.86	12.0				

P_1 [kW]	n_2 [Min ⁻¹]	M_2 [Nm]	f_B	i_{ges}	F_R [kN]	Typ / Type / Tipo / Type / Tipo	 Kg ~	 mm
0.37	3.9	847	1.0	234.50	12.0	A/F 403 - 71M/6 A/F 403 - 80M/6A	40	126
	4.3	776	1.1	215.01	12.0			
	4.9	672	1.3	186.14	12.0			
	5.4	616	1.4	170.55	12.0			
	6.2	540	1.6	149.47	12.0			
	6.8	489	1.7	135.37	12.0			
	7.8	426	2.0	118.13	12.0			
	9.7	342	2.5	94.86	12.0			
	10.7	310	2.7	85.91	12.0			
	4.1	804	2.2	222.59	18.0			
	4.7	704	2.6	194.86	18.0			
	5.1	646	2.8	178.98	18.0			
	5.7	586	3.1	162.21	18.0			
	6.0	558	3.2	154.52	18.0			
6.5	513	3.5	142.00	18.0				
0.55	80.6	65	0.8	17.37	2.5	A202 - 71M/4C F202 - 71M/4C	10	110
	88.9	59	0.9	15.75	2.5			
	97.1	54	0.9	14.42	2.5			
	105.8	50	0.9	13.23	2.5			
	121.5	43	1.2	11.52	2.5			
	139.6	38	1.5	10.03	2.5			
	156.8	34	1.6	8.93	2.5			
	174.3	30	1.8	8.03	2.5			
	194.2	27	2.0	7.21	2.5			
	213.7	25	2.2	6.55	2.5			
	234.1	22	2.5	5.98	2.5			
	255.0	21	2.7	5.49	2.5			
	262.7	20	2.8	5.33	2.5			
	292.3	18	2.9	4.79	2.5			
	326.3	16	3.1	4.29	2.5			
	359.0	15	3.1	3.90	2.5			
	393.3	13	3.6	3.56	2.5			
	429.4	12	3.8	3.26	2.5			
	471.4	11	3.8	2.97	2.5			
	494.7	11	3.7	2.83	2.5			
	549.0	10	3.8	2.55	2.5			
	606.1	9	3.7	2.31	2.5			
	660.4	8	3.8	2.12	2.5			
	50.6	104	0.9	27.66	2.8			
	56.4	93	1.0	24.83	2.8			
	62.4	84	1.1	22.44	2.8			
	68.8	76	1.1	20.35	2.8			
	75.1	70	1.2	18.63	2.8			
	88.9	59	1.4	15.74	2.8			
	103.2	51	1.7	13.56	2.8			
	115.8	45	1.9	12.09	2.8			
	122.7	43	2.0	11.41	2.8			
	129.0	41	2.1	10.85	2.8			
	142.7	37	2.3	9.81	2.8			
	160.0	33	2.7	8.75	2.8			
	179.3	29	2.8	7.81	2.8			
	58.8	82	1.8	47.93	5.5			
	67.1	72	2.1	42.00	5.5			
	73.3	66	2.3	38.46	5.5			
	84.5	57	2.6	33.38	5.5			
	93.5	52	2.9	30.15	5.5			
	105.3	46	3.3	26.79	5.5			
116.6	41	3.6	24.19	5.5				
122.4	39	3.8	23.04	5.5				



P₁ [kW]	n₂ [Min ⁻¹]	M₂ [Nm]	f_B	i_{ges}	F_R [kN]	Typ / Type / Tipo / Type / Tipo	kg ~	mm		
0.55	29.2	173	1.2	47.93	5.5	A/F 252 - 71M/4C A/F 252 - 80M/4A	20	114		
	33.3	151	1.3	42.00	5.5					
	36.4	139	1.4	38.46	5.5					
	41.9	120	1.7	33.38	5.5					
	46.4	109	1.8	30.15	5.5					
	52.3	96	2.1	26.79	5.5					
	57.9	87	2.3	24.19	5.5					
	60.8	83	2.4	23.04	5.5					
	69.3	73	2.8	20.19	5.5					
	75.7	67	3.0	18.49	5.5					
	82.1	61	3.1	17.05	5.5					
	93.9	54	3.2	14.91	5.5					
	100.4	50	3.4	13.94	5.5					
	117.0	43	3.4	11.97	5.5					
	135.7	37	3.8	10.32	5.4					
23.7	213	0.9	38.46	5.5	A252 - 80M/6B F252 - 80M/6B	22	114			
27.6	183	1.1	33.38	5.5						
30.5	165	1.2	30.15	5.5						
34.3	147	1.4	26.79	5.5						
38.0	133	1.5	24.19	5.5						
39.9	126	1.6	23.04	5.5						
45.6	111	1.8	20.19	5.5						
49.8	101	2.0	18.49	5.5						
54.0	93	2.0	17.05	5.5						
61.7	82	2.1	14.91	5.5						
66.0	76	2.2	13.94	5.5						
76.9	66	2.2	11.97	5.5						
89.1	57	2.5	10.32	5.4						
102.0	49	2.6	9.02	5.2						
116.0	43	2.9	7.93	5.0						
144.7	35	3.0	6.36	4.7						
191.7	26	3.6	4.80	4.4						
37.7	125	1.2	74.76	5.5	A253 - 71M/2B F253 - 71M/2B	20	114			
42.4	112	1.3	66.56	5.5						
52.8	90	1.7	53.41	5.5						
26.2	192	1.0	53.41	5.5	A/F 253 - 71M/4C A/F 253 - 80M/4A	20	114			
317.9	16	2.7	8.87	1.0	A301 - 71M/2B F301 - 71M/2B	16	116			
362.5	14	2.8	7.78	1.0						
456.3	11	3.5	6.18	1.0						
505.4	10	3.8	5.58	1.0						
555.1	9	3.8	5.08	1.0						
157.8	32	1.7	8.87	1.0	A/F 301 - 71M/4C A/F 301 - 80M/4A	16	116			
179.9	28	1.8	7.78	1.0						
226.5	22	2.2	6.18	1.0						
250.9	20	2.5	5.58	1.0						
275.6	18	2.4	5.08	1.0						
327.9	16	2.9	4.27	1.0						
383.6	13	3.4	3.65	1.0						
443.0	11	3.5	3.16	1.0						
507.2	10	3.0	2.76	0.9						
540.5	9	3.2	2.59	0.9						
686.3	7	3.4	2.04	0.9						
103.7	49	1.1	8.87	1.0	A301 - 80M/6B F301 - 80M/6B	18	116			
118.3	43	1.2	7.78	1.0						
148.9	34	1.5	6.18	1.0						
164.9	31	1.6	5.58	1.0						
181.1	28	1.6	5.08	1.0						
215.5	24	1.9	4.27	1.0						
252.1	20	2.2	3.65	1.0						
291.1	17	2.3	3.16	1.0						
333.3	15	2.0	2.76	1.0						
355.2	14	2.1	2.59	1.0						
451.0	11	2.2	2.04	0.9						
625.9	8	3.1	1.47	0.8						

P_1 [kW]	n_2 [Min ⁻¹]	M_2 [Nm]	f_B	i_{ges}	F_R [kN]	Typ / Type / Tipo / Type / Tipo	 Kg	 mm
0.55	51.2	94	2.2	55.03	6.6	A302 - 71M/2B F302 - 71M/2B	23	118
	58.5	83	2.5	48.22	6.6			
	63.5	76	2.8	44.38	6.6			
	73.6	66	3.2	38.33	6.6			
	81.5	59	3.5	34.62	6.6			
	91.2	53	4.0	30.91	6.6			
	25.4	198	1.4	55.03	6.6	A/F 302 - 71M/4C A/F 302 - 80M/4A	23	118
	29.0	174	1.6	48.22	6.6			
	31.5	160	1.8	44.38	6.6			
	36.5	138	2.0	38.33	6.6			
	40.4	125	2.2	34.62	6.6			
	45.3	111	2.5	30.91	6.6			
	50.1	101	2.8	27.92	6.6			
	52.9	95	2.7	26.45	6.6			
	59.6	85	3.1	23.49	6.6			
	65.6	77	3.3	21.33	6.6			
	72.6	69	3.6	19.29	6.6			
	16.7	302	0.9	55.03	6.6	A302 - 80M/6B F302 - 80M/6B	25	118
	19.1	264	1.1	48.22	6.6			
	20.7	243	1.2	44.38	6.6			
	24.0	210	1.3	38.33	6.6			
	26.6	190	1.5	34.62	6.6			
	29.8	169	1.7	30.91	6.6			
	33.0	153	1.8	27.92	6.6			
	34.8	145	1.8	26.45	6.6			
	39.2	129	2.0	23.49	6.6			
	43.1	117	2.1	21.33	6.6			
	47.7	106	2.4	19.29	6.6			
	56.8	89	2.8	16.21	6.6			
	66.6	76	3.3	13.81	6.6			
	76.7	66	3.8	12.00	6.6			
	22.4	211	1.1	125.65	6.6	A303 - 71M/2B F303 - 71M/2B	23	118
	24.6	192	1.2	114.42	6.6			
	32.4	146	1.5	86.96	6.6			
	36.9	128	1.8	76.42	6.6			
	45.8	103	2.2	61.63	6.6			
	12.2	404	0.7	114.42	6.6	A303 - 71M/4C F303 - 71M/4C	23	118
	16.1	307	1.0	86.96	6.6	A/F 303 - 71M/4C A/F 303 - 80M/4A	23	118
	18.3	270	1.1	76.42	6.6			
	22.7	217	1.4	61.63	6.6			
	14.9	331	0.9	61.63	6.6	A303 - 80M/6B F303 - 80M/6B	23	118
	164.7	31	3.2	8.50	2.5	A/F 351 - 71M/4C A/F 351 - 80M/4A	18	120
	188.1	27	3.7	7.44	2.5			
	108.2	47	2.1	8.50	2.5	A351 - 80M/6B F351 - 80M/6B	20	120
	123.6	41	2.4	7.44	2.5			
	155.7	33	3.1	5.91	2.5			
	172.5	30	3.4	5.33	2.5			
189.8	27	3.5	4.85	2.5				
49.5	100	3.8	56.95	8.0	A352 - 71M/2B F352 - 71M/2B	28	122	
24.6	201	2.4	56.95	8.0	A/F 352 - 71M/4C A/F 352 - 80M/4A	28	122	
28.1	176	2.8	49.88	8.0				
30.4	162	3.0	46.04	8.0				
35.4	140	3.5	39.59	8.0				
16.2	312	1.6	56.95	8.0	A352 - 80M/6B F352 - 80M/6B	30	122	
18.4	273	1.8	49.88	8.0				
20.0	252	1.9	46.04	8.0				
23.2	217	2.3	39.59	8.0				
27.5	184	2.7	33.50	8.0				
28.7	175	2.8	32.01	8.0				
31.8	158	3.1	28.89	8.0				
34.6	146	3.4	26.59	8.0				
36.6	138	3.4	25.13	8.0				

P₁ [kW]	n₂ [Min ⁻¹]	M₂ [Nm]	f_B	i_{ges}	F_R [kN]	Typ / Type / Tipo / Type / Tipo	Kg ~	mm
0.55	13.0	363	1.0	216.67	8.0	A353 - 71M/2B F353 - 71M/2B	30	122
	14.5	326	1.1	194.72	8.0			
	17.9	264	1.4	157.42	8.0			
	20.9	226	1.7	134.76	8.0			
	25.9	183	2.1	108.95	8.0			
	31.2	152	2.5	90.51	8.0			
	38.9	122	3.1	72.58	8.0			
	48.1	98	3.8	58.68	8.0			
	8.9	555	0.9	157.42	8.0	A353 - 71M/4C F353 - 71M/4C	30	122
	10.4	475	1.1	134.76	8.0	A/F 353 - 71M/4C A/F 353 - 80M/4A	30	122
	12.8	384	1.3	108.95	8.0			
	15.5	319	1.6	90.51	8.0			
	19.3	256	2.0	72.58	8.0			
	23.9	207	2.4	58.68	8.0			
	10.2	486	1.0	90.51	8.0	A353 - 80M/6B F353 - 80M/6B	30	122
	12.7	390	1.3	72.58	8.0			
	15.7	315	1.6	58.68	8.0			
	111.5	46	3.7	8.25	3.7	A401 - 80M/6B F401 - 80M/6B	20	124
	20.3	249	3.4	45.38	12.0	A402 - 80M/6B F402 - 80M/6B	41	126
	23.2	218	3.9	39.72	12.0			
10.5	449	1.4	267.75	12.0	A403 - 71M/2B F403 - 71M/2B	38	126	
12.0	393	1.6	234.50	12.0				
13.1	360	1.8	215.01	12.0				
15.1	312	2.0	186.14	12.0				
16.5	286	2.2	170.55	12.0				
18.9	251	2.5	149.47	12.0				
20.8	227	2.8	135.37	12.0				
23.9	198	3.2	118.13	12.0				
29.7	159	4.0	94.86	12.0				
5.2	944	0.9	267.75	12.0				A/F 403 - 71M/4C A/F 403 - 80M/4A
6.0	827	1.0	234.50	12.0				
6.5	758	1.1	215.01	12.0				
7.5	656	1.3	186.14	12.0				
8.2	601	1.4	170.55	12.0				
9.4	527	1.6	149.47	12.0				
10.3	477	1.8	135.37	12.0				
11.9	417	2.0	118.13	12.0				
14.8	335	2.5	94.86	12.0				
16.3	303	2.8	85.91	12.0				
5.4	915	0.9	170.55	12.0	A403 - 80M/6B F403 - 80M/6B	41	126	
6.2	802	1.1	149.47	12.0				
6.8	726	1.2	135.37	12.0				
7.8	634	1.3	118.13	12.0				
9.7	509	1.7	94.86	12.0				
10.7	461	1.8	85.91	12.0				
6.3	785	2.3	222.59	18.0	A503 - 80M/4A F503 - 80M/4A	55	130	
7.2	687	2.6	194.86	18.0				
7.8	631	2.9	178.98	18.0				
8.6	572	3.1	162.21	18.0				
9.1	545	3.3	154.52	18.0				
9.9	501	3.6	142.00	18.0				
4.1	1195	1.5	222.59	18.0	A503 - 80M/6B F503 - 80M/6B	58	130	
4.7	1046	1.7	194.86	18.0				
5.1	961	1.9	178.98	18.0				
5.7	871	2.1	162.21	18.0				
6.0	829	2.2	154.52	18.0				
6.5	762	2.4	142.00	18.0				
7.4	667	2.7	124.25	18.0				
8.2	604	3.0	112.61	18.0				
9.4	525	3.4	97.80	18.0				
10.8	458	3.9	85.33	18.0				

P_1 [kW]	n_2 [Min ⁻¹]	M_2 [Nm]	f_B	i_{ges}	F_R [kN]	Typ / Type / Tipo / Type / Tipo	 Kg	 mm				
0.75	62.4	115	0.8	22.44	2.8	A 202 G - 80M/4B F 202 G - 80M/4B	14	112				
	68.8	104	0.8	20.35	2.8							
	75.1	95	0.9	18.63	2.8							
	88.9	81	1.1	15.74	2.8							
	103.2	69	1.2	13.56	2.8							
	115.8	62	1.4	12.09	2.8							
	122.7	58	1.5	11.41	2.8							
	129.0	56	1.5	10.85	2.8							
	142.7	50	1.7	9.81	2.8							
	160.0	45	2.0	8.75	2.8							
	179.3	40	2.1	7.81	2.8							
	198.9	36	2.3	7.04	2.8							
	218.4	33	2.5	6.41	2.8							
	243.9	29	2.6	5.74	2.8							
	271.3	26	3.1	5.16	2.8							
	302.4	24	3.0	4.63	2.8							
	334.1	21	3.0	4.19	2.8							
	367.5	19	3.0	3.81	2.8							
	407.0	18	3.1	3.44	2.8							
	432.1	17	3.3	3.24	2.8							
	474.6	15	3.3	2.95	2.8							
	510.9	14	3.3	2.74	2.8							
	557.8	13	3.3	2.51	2.8							
	606.1	12	3.6	2.31	2.8							
		59.3	111	1.3	47.93				5.5	A/F 252 - 71M/2C A/F 252 - 80M/2A	20	114
		67.6	97	1.5	42.00				5.5			
		73.8	89	1.7	38.46				5.5			
		85.1	77	1.9	33.38				5.5			
		94.2	70	2.1	30.15				5.5			
		106.0	62	2.4	26.79				5.5			
		117.4	56	2.7	24.19				5.5			
		123.3	53	2.8	23.04				5.5			
		140.6	47	3.2	20.19				5.4			
		153.6	43	3.5	18.49				5.5			
		166.5	40	3.6	17.05				5.5			
		190.4	35	3.7	14.91				5.5			
		203.8	32	3.9	13.94				5.5			
		237.3	28	3.9	11.97				5.3			
		33.3	206	1.0	42.00				5.5	A252 - 80M/4B F252 - 80M/4B	21	114
		36.4	189	1.1	38.46				5.5			
		41.9	164	1.2	33.38				5.5			
	46.4	148	1.4	30.15	5.5							
	52.3	132	1.5	26.79	5.5							
	57.9	119	1.7	24.19	5.5							
	60.8	113	1.8	23.04	5.5							
	69.3	99	2.0	20.19	5.4							
	75.7	91	2.2	18.49	5.5							
	82.1	84	2.3	17.05	5.5							
	93.9	73	2.3	14.91	5.5							
	100.4	68	2.5	13.94	5.5							
	117.0	59	2.5	11.97	5.3							
	135.7	51	2.8	10.32	5.2							
	155.2	44	2.9	9.02	5.0							
	176.5	39	3.2	7.93	4.9							
	220.0	31	3.4	6.36	4.6							
	30.7	224	0.9	30.15	5.5	A/F 252 - 80C/6 A/F 252 - 90S/6A	21	114				
	34.5	199	1.0	26.79	5.5							
	38.2	180	1.1	24.19	5.5							
	40.1	171	1.2	23.04	5.5							
	45.8	150	1.3	20.19	5.5							
	50.0	137	1.5	18.49	5.5							
	54.2	127	1.5	17.05	5.5							
	62.0	111	1.5	14.91	5.5							
	66.4	104	1.6	13.94	5.5							
	77.3	89	1.6	11.97	5.3							
	89.7	77	1.8	10.32	5.2							
	102.5	67	1.9	9.02	5.0							
	116.6	59	2.1	7.93	4.9							
	145.3	47	2.2	6.36	4.6							
	192.8	36	2.7	4.80	4.3							

P₁ [kW]	n₂ [Min ⁻¹]	M₂ [Nm]	f_B	i_{ges}	F_R [kN]	Typ / Type / Tipo / Type / Tipo	kg ~	mm
0.75	53.2	121	1.2	53.41	5.5	A/F 253 - 71M/2C A/F 253 - 80M/2A	20	114
	320.2	21	2.0	8.87	1.0	A/F 301 - 71M/2C A/F 301 - 80M/2A	16	116
	365.0	18	2.0	7.78	1.0			
	459.5	15	2.6	6.18	1.0			
	509.0	13	2.8	5.58	1.0			
	559.1	12	2.8	5.08	1.0			
	665.1	10	3.3	4.27	1.0			
	778.7	9	3.9	3.65	1.0			
	899.3	7	4.0	3.16	1.0			
	1028.3	7	3.4	2.76	0.9			
	1096.1	6	3.7	2.59	0.9			
	1393.2	5	3.9	2.04	0.8			
	157.8	44	1.2	8.87	1.0	A301 - 80M/4B F301 - 80M/4B	17	116
	179.9	39	1.3	7.78	1.0			
	226.5	31	1.6	6.18	1.0			
	250.9	28	1.8	5.58	1.0			
	275.6	25	1.8	5.08	1.0			
	327.9	21	2.1	4.27	1.0			
	383.9	18	2.5	3.65	1.0			
	443.3	16	2.6	3.16	1.0			
	506.9	14	2.2	2.76	0.9			
	540.4	13	2.3	2.59	0.9			
	686.8	10	2.5	2.04	0.8			
	953.2	7	3.4	1.47	0.8			
	118.9	58	0.9	7.78	1.0	A/F 301 - 80C/6 A/F 301 - 90S/6A	20	116
	149.6	46	1.1	6.18	1.0			
	165.7	42	1.2	5.58	1.0			
	182.2	38	1.2	5.08	1.0			
	216.8	32	1.4	4.27	1.0			
	253.6	27	1.6	3.65	1.0			
	292.9	24	1.7	3.16	1.0			
	334.9	21	1.4	2.76	1.0			
	357.0	19	1.5	2.59	1.0			
	453.8	15	1.6	2.04	0.9			
	629.8	11	2.3	1.47	0.8			
	51.6	128	1.6	55.03	6.6	A/F 302 - 71M/2C A/F 302 - 80M/2A	23	118
	58.9	112	1.9	48.22	6.6			
	64.0	103	2.0	44.38	6.6			
	74.1	89	2.4	38.33	6.6			
	82.0	80	2.6	34.62	6.6			
	91.9	72	2.9	30.91	6.6			
	101.7	65	3.2	27.92	6.6			
	107.4	61	3.2	26.45	6.6			
	120.9	55	3.6	23.49	6.6			
	133.1	49	3.8	21.33	6.6			
	25.4	270	1.0	55.03	6.6			
	29.0	237	1.2	48.22	6.6			
31.5	218	1.3	44.38	6.6				
36.5	188	1.5	38.33	6.6				
40.4	170	1.6	34.62	6.6				
45.3	152	1.8	30.91	6.6				
50.1	137	2.0	27.92	6.6				
52.9	130	2.0	26.45	6.6				
59.6	115	2.3	23.49	6.6				
65.6	105	2.4	21.33	6.6				
72.6	95	2.6	19.29	6.6				
86.3	80	3.1	16.21	6.6				
101.4	68	3.7	13.81	6.6				

P_1 [kW]	n_2 [Min ⁻¹]	M_2 [Nm]	f_B	i_{ges}	F_R [kN]	Typ / Type / Tipo / Type / Tipo	 Kg	 mm
0.75	24.1	285	1.0	38.33	6.6	A/F 302 - 80C/6 A/F 302 - 90S/6A	27	118
	26.7	257	1.1	34.62	6.6			
	29.9	230	1.2	30.91	6.6			
	33.1	208	1.3	27.92	6.6			
	35.0	197	1.3	26.45	6.6			
	39.4	175	1.5	23.49	6.6			
	43.4	159	1.6	21.33	6.6			
	47.9	143	1.7	19.29	6.6			
	57.1	121	2.1	16.21	6.6			
	67.0	103	2.4	13.81	6.6			
	77.1	89	2.8	12.00	6.6			
	88.1	78	3.1	10.50	6.6			
	101.6	68	3.1	9.11	6.6			
	126.0	55	2.9	7.34	6.2			
	165.7	41	3.9	5.58	5.7			
	32.7	206	1.1	86.96	6.6	A/F 303 - 71M/2C A/F 303 - 80M/2A	23	118
	37.2	181	1.3	76.42	6.6			
	46.1	146	1.6	61.63	6.6			
	22.7	296	1.0	61.63	6.6	A303 - 80M/4B F303 - 80M/4B	24	118
	334.1	21	3.8	8.50	2.5	A/F 351 - 71M/2C A/F 351 - 80M/2A	18	120
	164.7	42	2.4	8.50	2.5	A351 - 80M/4B F351 - 80M/4B	19	120
	188.1	37	2.7	7.44	2.5			
	236.9	29	3.4	5.91	2.5			
	262.5	26	3.8	5.33	2.5			
	108.8	64	1.6	8.50	2.5	A/F 351 - 80C/6 A/F 351 - 90S/6A	22	120
	124.3	56	1.8	7.44	2.5			
	156.5	44	2.3	5.91	2.5			
	173.4	40	2.5	5.33	2.5			
	190.9	36	2.6	4.85	2.5			
	227.5	31	2.9	4.07	2.5			
	246.7	28	3.2	3.75	2.5			
	287.1	24	3.3	3.22	2.5			
	353.2	20	3.6	2.62	2.3			
	426.9	16	3.7	2.17	2.2			
	49.9	132	2.8	56.95	8.0	A/F 352 - 71M/2C A/F 352 - 80M/2A	28	122
	56.9	116	3.2	49.88	8.0			
	61.7	107	3.4	46.04	8.0			
	71.7	92	4.0	39.59	8.0			
	24.6	280	1.8	56.95	8.0	A352 - 80M/4B F352 - 80M/4B	29	122
	28.1	245	2.0	49.88	8.0			
	30.4	226	2.2	46.04	8.0			
	35.4	194	2.5	39.59	8.0			
	41.8	165	3.0	33.50	8.0			
	43.7	157	3.1	32.01	8.0			
	48.5	142	3.5	28.89	8.0			
	52.6	131	3.8	26.59	8.0			
	55.7	123	3.8	25.13	8.0			
	16.2	423	1.2	56.95	8.0			
	18.5	371	1.3	49.88	8.0			
	20.1	342	1.4	46.04	8.0			
	23.4	294	1.7	39.59	8.0			
	27.6	249	2.0	33.50	8.0			
	28.9	238	2.1	32.01	8.0			
	32.0	215	2.3	28.89	8.0			
	34.8	198	2.5	26.59	8.0			
	36.8	187	2.5	25.13	8.0			
	42.0	164	2.9	22.03	8.0			
	45.5	151	3.0	20.31	8.0			
	50.5	136	3.4	18.30	8.0			
	54.8	125	3.6	16.88	8.0			
	18.0	357	1.0	157.42	8.0	A353 - 71M/2C F353 - 71M/2C	28	122



P₁ [kW]	n₂ [Min ⁻¹]	M₂ [Nm]	f_B	i_{ges}	F_R [kN]	Typ / Type / Tipo / Type / Tipo	kg ~	mm
0.75	21.1	306	1.2	134.76	8.0	A/F 353 - 80C/6 A/F 353 - 90S/6A	32	122
	26.1	247	1.5	108.95	8.0			
	31.4	205	1.8	90.51	8.0			
	39.1	165	2.3	72.58	8.0			
	48.4	133	2.8	58.68	8.0			
	12.8	524	1.0	108.95	8.0	A353 - 80M/4B F353 - 80M/4B	29	122
	15.5	435	1.1	90.51	8.0			
	19.3	349	1.4	72.58	8.0			
	23.9	282	1.8	58.68	8.0			
	12.7	528	0.9	72.58	8.0	A/F 353 - 80C/6 A/F 353 - 90S/6A	32	122
	15.8	427	1.2	58.68	8.0			
	112.1	62	2.7	8.25	3.7	A/F 401 - 80C/6 A/F 401 - 90S/6A	22	124
	128.1	54	3.1	7.22	3.7			
	161.5	43	4.0	5.73	3.7			
	30.9	223	3.8	45.38	12.0	A402 - 80M/4B F402 - 80M/4B	40	126
	20.4	337	2.5	45.38	12.0	A/F 402 - 80C/6 A/F 402 - 90S/6A	43	126
	23.3	295	2.9	39.72	12.0			
	25.4	271	3.1	36.44	12.0			
	29.4	234	3.6	31.50	12.0			
	32.0	215	4.0	28.89	12.0			
	10.6	608	1.0	267.75	12.0	A403 - 71M/2C F403 - 71M/2C	38	126
	12.1	533	1.2	234.67	12.0	A/F 403 - 71M/2C A/F 403 - 80M/2A	38	126
	13.2	488	1.3	215.21	12.0			
	15.3	423	1.5	186.14	12.0			
	16.7	387	1.6	170.55	12.0			
	19.0	339	1.9	149.47	12.0			
	21.0	307	2.1	135.37	12.0			
	24.0	268	2.4	118.13	12.0			
	29.9	215	3.0	94.86	12.0			
	33.1	195	3.3	85.91	12.0			
	7.5	895	0.9	186.14	12.0			
	8.2	820	1.0	170.55	12.0			
9.4	719	1.2	149.47	12.0				
10.3	651	1.3	135.37	12.0				
11.9	568	1.5	118.13	12.0				
14.8	456	1.9	94.86	12.0				
16.3	413	2.1	85.91	12.0				
7.8	860	1.0	118.13	12.0	A/F 403 - 80C/6 A/F 403 - 90S/6A	43	126	
9.8	690	1.2	94.86	12.0				
10.8	625	1.4	85.91	12.0				
13.6	497	1.7	68.25	12.0	A403 - 90S/6A F403 - 90S/6A	43	126	
16.9	399	2.1	54.81	12.0				
18.6	361	2.4	49.64	12.0				
12.8	505	2.7	222.59	18.0	A503 - 80M/2A F503 - 80M/2A	57	130	
14.6	442	3.1	194.86	18.0				
15.9	406	3.3	178.98	18.0				
17.5	368	3.7	162.21	18.0				
18.4	351	3.8	154.52	18.0				
6.3	1070	1.7	222.59	18.0	A503 - 80M/4B F503 - 80M/4B	57	130	
7.2	937	1.9	194.86	18.0				
7.8	861	2.1	178.98	18.0				
8.6	780	2.3	162.21	18.0				
9.1	743	2.4	154.52	18.0				
9.9	683	2.6	142.00	18.0				
11.3	598	3.0	124.25	18.0				
12.4	542	3.3	112.61	18.0				
14.3	470	3.8	97.80	18.0				



P_1 [kW]	n_2 [Min ⁻¹]	M_2 [Nm]	f_B	i_{ges}	F_R [kN]	Typ / Type / Tipo / Type / Tipo	Kg	mm				
0.75	4.2	1620	1.1	222.59	18.0	A/F 503 - 80C/6 A/F 503 - 90S/6A	60	130				
	4.7	1418	1.3	194.86	18.0							
	5.2	1303	1.4	178.98	18.0							
	5.7	1181	1.5	162.21	18.0							
	6.0	1125	1.6	154.52	18.0							
	6.5	1034	1.7	142.00	18.0							
	7.4	904	2.0	124.25	18.0							
	8.2	820	2.2	112.61	18.0							
	9.5	712	2.5	97.80	18.0							
	10.8	621	2.9	85.33	18.0							
	11.8	572	3.1	78.64	18.0							
	13.0	519	3.5	71.27	18.0							
	16.5	409	3.9	56.21	18.0							
	0.75	3.8	1766	2.0	242.67				22.0	A603 - 90S/6A F603 - 90S/6A	88	134
		4.3	1569	2.2	215.56				22.0			
		4.8	1414	2.5	194.31				22.0			
		5.1	1318	2.7	181.13				22.0			
5.7		1171	3.0	160.90	22.0							
6.4		1045	3.3	143.57	22.0							
0.92	42.2	200	1.0	33.38	5.5	A252 - 80M/4 F252 - 80M/4	21	114				
	46.8	180	1.1	30.15	5.5							
	52.6	160	1.2	26.79	5.4							
	58.3	145	1.4	24.19	5.4							
	61.2	138	1.5	23.04	5.3							
	69.8	121	1.7	20.19	5.2							
	76.3	111	1.8	18.49	5.1							
	94.6	89	1.9	14.91	4.9							
	101.1	83	2.0	13.94	4.9							
	117.8	72	2.0	11.97	4.7							
	136.7	62	2.3	10.32	4.5							
	156.3	54	2.4	9.02	4.4							
	177.8	47	2.6	7.93	4.2							
	221.5	38	2.8	6.36	4.0							
	293.9	29	3.3	4.80	3.7							
	0.92	159.0	54	1.0	8.87				1.0	A301 - 80M/4 F301 - 80M/4	17	116
		181.2	47	1.1	7.78				1.0			
		228.1	37	1.3	6.18				1.0			
		252.7	34	1.5	5.58				1.0			
		277.6	31	1.5	5.08				0.9			
		330.2	26	1.7	4.27				0.9			
		386.3	22	2.0	3.65				0.9			
		446.2	19	2.1	3.16				0.8			
		510.9	17	1.8	2.76				0.8			
		544.4	16	1.9	2.59				0.8			
		691.2	12	2.0	2.04				0.7			
		959.2	9	2.8	1.47				0.7			
		0.92	29.2	288	1.0				48.22			
	31.8		265	1.1	44.38				6.6			
	36.8		229	1.2	38.33				6.6			
	40.7		207	1.4	34.62				6.6			
	45.6		185	1.5	30.91				6.6			
	50.5		167	1.7	27.92				6.6			
53.3	158		1.6	26.45	6.6							
60.0	141		1.9	23.49	6.6							
66.1	128		2.0	21.33	6.6							
73.1	115		2.2	19.29	6.6							
87.0	97		2.6	16.21	6.6							
102.1	83		3.0	13.81	6.4							
117.5	72		3.5	12.00	6.2							
134.3	63		3.8	10.50	5.9							
154.8	54		3.9	9.11	5.7							
192.0	44	3.6	7.34	5.4								
0.92	165.9	51	1.9	8.50	2.5	A351 - 80M/4 F351 - 80M/4	19	120				
	189.5	45	2.2	7.44	2.5							
	238.6	36	2.8	5.91	2.5							
	264.4	32	3.1	5.33	2.5							
	291.0	29	3.2	4.85	2.5							
	346.7	25	3.7	4.07	2.3							



P₁ [kW]	n₂ [Min ⁻¹]	M₂ [Nm]	f_B	i_{ges}	F_R [kN]	Typ / Type / Tipo / Type / Tipo	kg ~	mm
0.92	24.8	341	1.4	56.95	8.0	A352 - 80M/4 F352 - 80M/4	29	122
	28.3	298	1.6	49.88	8.0			
	30.6	275	1.8	46.04	8.0			
	35.6	237	2.1	39.59	8.0			
	42.1	200	2.4	33.50	8.0			
	44.1	191	2.6	32.01	8.0			
	48.8	173	2.8	28.89	8.0			
	53.0	159	3.1	26.59	8.0			
	56.1	150	3.1	25.13	8.0			
	64.0	132	3.6	22.03	8.0			
	69.4	122	3.8	20.31	8.0			
	15.6	530	0.9	90.51	8.0			
	19.4	425	1.2	72.58	8.0			
	24.0	344	1.5	58.68	8.0			
	170.9	53	3.2	8.25	3.7	A401 - 80M/4 F401 - 80M/4	29	124
	195.2	46	3.7	7.22	3.7			
	31.1	295	2.9	45.38	12.0	A402 - 80M/4 F402 - 80M/4	29	126
	35.5	258	3.3	39.72	12.0			
	38.7	237	3.4	36.44	12.0			
	9.4	875	1.0	149.47	12.0	A403 - 80M/4 F403 - 80M/4	40	126
	10.4	793	1.1	135.37	12.0			
11.9	692	1.2	118.13	12.0				
14.9	556	1.5	94.86	12.0				
16.4	503	1.7	85.91	12.0				
6.3	1304	1.4	222.59	18.0	A503 - 80M/4 F503 - 80M/4	57	130	
7.2	1141	1.6	194.86	18.0				
7.9	1048	1.7	178.98	18.0				
8.7	950	1.9	162.21	18.0				
9.1	905	2.0	154.52	18.0				
9.9	941	1.9	142.00	18.0				
11.3	824	2.2	124.25	18.0				
12.5	746	2.4	112.61	18.0				
14.4	648	2.8	97.80	18.0				
16.5	566	3.2	85.33	18.0				
17.9	521	3.5	78.64	18.0				
1.10	123.6	85	1.0	11.41	2.8	A 202 G - 90S/4A F 202 G - 90S/4A	17	112
	143.7	73	1.2	9.81	2.8			
	161.1	65	1.3	8.75	2.8			
	180.5	58	1.4	7.81	2.8			
	200.3	52	1.6	7.04	2.8			
	220.0	48	1.7	6.41	2.8			
	245.6	43	1.8	5.74	2.8			
	273.3	38	2.2	5.16	2.8			
	304.5	34	2.1	4.63	2.8			
	336.5	31	2.1	4.19	2.8			
	370.1	28	2.1	3.81	2.8			
	409.9	26	2.1	3.44	2.8			
	435.2	24	2.2	3.24	2.8			
	478.0	22	2.3	2.95	2.8			
	514.6	20	2.3	2.74	2.8			
	561.8	19	2.3	2.51	2.8			
	610.4	17	2.5	2.31	2.8			
	67.9	142	1.1	42.00	5.0	A252 - 80M/2B F252 - 80M/2B	21	114
	74.1	130	1.2	38.46	5.0			
	85.4	113	1.3	33.38	4.9			
	94.5	102	1.5	30.15	4.8			
	106.4	91	1.7	26.79	4.7			
	117.8	82	1.8	24.19	4.6			
	123.7	78	1.9	23.04	4.5			
	141.1	68	2.2	20.19	4.4			
	154.1	63	2.4	18.49	4.3			
	167.1	58	2.5	17.05	4.2			
191.1	51	2.5	14.91	4.1				
204.5	47	2.7	13.94	4.0				
238.1	41	2.7	11.97	3.9				
276.3	35	3.0	10.32	3.7				
315.9	31	3.2	9.02	3.6				
359.3	27	3.5	7.93	3.5				
447.8	22	3.6	6.36	3.3				

P_1 [kW]	n_2 [Min ⁻¹]	M_2 [Nm]	f_B	i_{ges}	F_R [kN]	Typ / Type / Tipo / Type / Tipo	Kg ~	mm
1.10	46.8	216	0.9	30.15	5.1	A/F 252 - 80M/4C A/F 252 - 90S/4A	24	114
	52.6	192	1.0	26.79	5.1			
	58.3	173	1.2	24.19	5.1			
	61.2	165	1.2	23.04	5.0			
	69.8	144	1.4	20.19	5.0			
	76.3	132	1.5	18.49	4.9			
	82.7	122	1.6	17.05	4.8			
	94.6	107	1.6	14.91	4.7			
	101.1	100	1.7	13.94	4.7			
	117.8	86	1.7	11.97	4.5			
	136.6	74	1.9	10.32	4.4			
	156.3	65	2.0	9.02	4.3			
	177.8	57	2.2	7.93	4.2	A252 - 90L/6B F252 - 90L/6B	28	114
	221.5	46	2.3	6.36	3.9			
	293.9	34	2.8	4.80	3.7			
	46.3	220	0.9	20.19	5.1			
	50.6	201	1.0	18.49	5.1			
	54.8	186	1.0	17.05	5.1			
	62.7	163	1.0	14.91	5.0			
	67.1	152	1.1	13.94	5.0			
	78.1	130	1.1	11.97	4.9			
	90.6	112	1.2	10.32	4.8			
	103.6	98	1.3	9.02	4.7			
	117.9	86	1.4	7.93	4.6			
	146.9	69	1.5	6.36	4.4	A301 - 80M/2B F301 - 80M/2B	17	116
	194.9	52	1.8	4.80	4.1			
	321.1	31	1.3	8.88	0.9			
	366.3	27	1.4	7.78	0.9			
	461.2	21	1.8	6.18	0.9			
	510.8	19	1.9	5.58	0.8			
	561.0	18	1.9	5.08	0.8			
	667.4	15	2.3	4.27	0.8			
	780.8	13	2.7	3.65	0.8			
	901.9	11	2.7	3.16	0.7			
	1032.6	10	2.4	2.76	0.7			
	1100.4	9	2.5	2.59	0.7			
	1397.1	7	2.7	2.04	0.6	A/F 301 - 80M/4C A/F 301 - 90S/4A	20	116
	1938.8	5	3.7	1.47	0.5			
	181.2	56	0.9	7.78	1.0			
	228.2	45	1.1	6.18	1.0			
	252.7	40	1.2	5.58	1.0			
	277.6	37	1.2	5.08	1.0			
	330.2	31	1.5	4.27	0.9			
	386.3	26	1.7	3.65	0.9			
	446.2	23	1.8	3.16	0.9			
	510.9	20	1.5	2.76	0.8			
	544.4	19	1.6	2.59	0.8			
	691.2	15	1.7	2.04	0.8			
	959.2	11	2.4	1.47	0.7	A301 - 90L/6B F301 - 90L/6B	24	116
	219.0	47	1.0	4.27	1.0			
	256.2	40	1.1	3.65	1.0			
	295.9	34	1.2	3.16	1.0			
	338.8	30	1.0	2.76	0.9			
	361.0	28	1.1	2.59	0.9			
	458.3	22	1.1	2.04	0.9			
	636.1	16	1.6	1.47	0.8	A302 - 80M/2B F302 - 80M/2B	24	118
	51.8	187	1.1	55.03	6.6			
	59.1	164	1.3	48.22	6.6			
	64.2	150	1.4	44.38	6.6			
	74.4	130	1.6	38.33	6.6			
	82.3	117	1.8	34.62	6.6			
	92.2	105	2.0	30.91	6.6			
	102.1	95	2.2	27.92	6.6			
	107.7	90	2.2	26.45	6.6			
	121.3	80	2.4	23.49	6.6			
	133.6	72	2.6	21.33	6.6			
	147.7	65	2.9	19.29	6.6			
	175.8	55	3.4	16.21	6.5			
	206.4	47	4.0	13.81	6.3			



P₁ [kW]	n₂ [Min ⁻¹]	M₂ [Nm]	f_B	i_{ges}	F_R [kN]	Typ / Type / Tipo / Type / Tipo	Kg ~	mm
1.10	36.8	274	1.0	38.33	6.6	A/F 302 - 80M/4C A/F 302 - 90S/4A	27	118
	40.7	248	1.1	34.62	6.6			
	45.6	221	1.3	30.91	6.6			
	50.5	200	1.4	27.92	6.6			
	53.3	189	1.4	26.45	6.6			
	60.0	168	1.5	23.49	6.6			
	66.1	153	1.6	21.33	6.6			
	73.1	138	1.8	19.29	6.6			
	87.0	116	2.2	16.21	6.5			
	102.1	99	2.5	13.81	6.3			
	117.5	86	2.9	12.00	6.1			
	134.3	75	3.2	10.50	5.8			
	154.8	65	3.2	9.11	5.6			
	192.0	53	3.0	7.34	5.3			
	33.5	301	0.9	27.92	6.6			
35.3	285	0.9	26.45	6.6				
39.8	253	1.0	23.49	6.6				
43.8	230	1.1	21.33	6.6				
48.5	208	1.2	19.29	6.6				
57.7	175	1.4	16.21	6.6				
67.7	149	1.7	13.81	6.6				
77.9	129	1.9	12.00	6.6				
89.1	113	2.1	10.50	6.5				
102.7	98	2.1	9.11	6.3				
127.3	79	2.0	7.34	6.0				
167.5	60	2.7	5.58	5.5				
46.2	204	1.1	61.63	6.6	A303 - 80M/2B F303 - 80M/2B	24	118	
335.3	29	2.5	8.50	2.5	A351 - 80M/2B F351 - 80M/2B	19	120	
382.8	26	2.9	7.44	2.5				
482.3	20	3.7	5.91	2.5				
165.9	61	1.6	8.50	2.5	A/F 351 - 80M/4C A/F 351 - 90S/4A	22	120	
189.4	54	1.9	7.44	2.5				
238.6	43	2.3	5.91	2.5				
264.4	39	2.6	5.33	2.5				
291.0	35	2.7	4.85	2.5				
346.7	29	3.1	4.07	2.5				
376.0	27	3.3	3.75	2.5				
437.6	23	3.4	3.22	2.4				
538.4	19	3.7	2.62	2.3				
650.8	16	3.8	2.17	2.2				
110.0	93	1.1	8.50	2.5	A351 - 90L/6B F351 - 90L/6B	26	120	
125.6	81	1.2	7.44	2.5				
158.2	64	1.6	5.91	2.5				
175.3	58	1.7	5.33	2.5				
192.9	53	1.8	4.85	2.5				
229.9	44	2.0	4.07	2.5				
249.3	41	2.2	3.75	2.5				
290.2	35	2.3	3.22	2.5				
357.0	29	2.5	2.62	2.5				
431.5	24	2.5	2.17	2.4				
644.1	16	3.8	1.45	1.9				
717.6	14	2.8	1.30	2.0				
50.0	193	1.9	56.95	8.0	A352 - 80M/2B F352 - 80M/2B	29	122	
57.1	169	2.2	49.88	8.0				
61.9	156	2.4	46.04	8.0				
72.0	134	2.7	39.59	8.0				
85.1	114	3.2	33.50	8.0				
89.0	109	3.4	32.01	8.0				
98.7	98	3.8	28.89	8.0				

P_1 [kW]	n_2 [Min ⁻¹]	M_2 [Nm]	f_B	i_{ges}	F_R [kN]	Typ / Type / Tipo / Type / Tipo	 Kg	 mm			
1.10	24.8	407	1.2	56.95	8.0	A/F 352 - 80M/4C A/F 352 - 90S/4A	32	122			
	28.3	357	1.4	49.88	8.0						
	30.6	329	1.5	46.04	8.0						
	35.6	283	1.7	39.59	8.0						
	42.1	240	2.0	33.50	8.0						
	44.0	229	2.1	32.01	8.0						
	48.8	207	2.4	28.89	8.0						
	53.0	190	2.6	26.59	8.0						
	56.1	180	2.6	25.13	8.0						
	64.0	158	3.0	22.03	8.0						
	69.4	145	3.2	20.31	8.0						
	77.0	131	3.5	18.30	8.0						
	83.6	121	3.7	16.88	8.0						
	18.7	538	0.9	49.88	8.0				A352 - 90L/6B F352 - 90L/6B	36	122
	20.3	497	1.0	46.04	8.0						
23.6	427	1.1	39.59	8.0							
27.9	361	1.4	33.50	8.0							
29.2	345	1.4	32.01	8.0							
32.4	312	1.6	28.89	8.0							
35.2	287	1.7	26.59	8.0							
37.2	271	1.7	25.13	8.0							
42.4	238	2.0	22.03	8.0							
46.0	219	2.1	20.31	8.0							
51.1	197	2.3	18.30	8.0							
55.4	182	2.5	16.88	8.0							
64.4	157	2.7	14.52	8.0							
79.7	127	3.1	11.74	8.0							
95.9	105	3.5	9.75	8.0							
107.1	94	3.6	8.73	8.0							
132.5	76	3.8	7.06	7.6							
26.2	361	1.0	108.95	8.0	A353 - 80M/2B F353 - 80M/2B	29	122				
31.5	300	1.2	90.51	8.0							
39.3	241	1.6	72.58	8.0							
48.6	195	1.9	58.68	8.0							
19.4	508	1.0	72.58	8.0	A/F 353 - 80M/4C A/F 353 - 90S/4A	32	122				
24.0	411	1.2	58.68	8.0							
170.9	60	2.9	8.25	3.7	A/F 401 - 80M/4C A/F 401 - 90S/4A	22	124				
195.2	52	3.3	7.22	3.7							
113.3	90	1.9	8.25	3.7	A401 - 90L/6B F401 - 90L/6B	26	124				
129.5	79	2.2	7.22	3.7							
163.3	62	2.7	5.73	3.7							
181.0	56	3.0	5.17	3.7							
199.3	51	3.1	4.69	3.7							
237.7	43	3.5	3.93	3.7							
257.9	40	3.8	3.63	3.7							
300.5	34	3.8	3.11	3.7							
62.8	161	4.1	45.38	12.0	A402 - 80M/2B F402 - 80M/2B	40	126				
31.1	325	2.6	45.38	12.0	A/F 402 - 80M/4C A/F 402 - 90S/4A	43	126				
35.5	284	3.0	39.72	12.0							
38.7	261	3.1	36.44	12.0							
44.8	225	3.8	31.50	12.0							
48.8	207	3.9	28.89	12.0							
20.6	489	1.7	45.38	12.0	A402 - 90L/6B F402 - 90L/6B	47	126				
23.5	428	2.0	39.72	12.0							
25.7	393	2.0	36.44	12.0							
29.7	340	2.5	31.50	12.0							
32.4	312	2.6	28.89	12.0							
37.0	273	3.1	25.30	12.0							
40.8	247	3.4	22.91	12.0							
46.9	215	4.0	19.94	12.0							

P_1 [kW]	n_2 [Min ⁻¹]	M_2 [Nm]	f_B	i_{ges}	F_R [kN]	Typ / Type / Tipo / Type / Tipo	 Kg	 mm
1.10	15.3	617	1.0	186.14	12.0	A403 - 80M/2B F403 - 80M/2B	40	126
	16.7	566	1.1	170.55	12.0			
	19.1	496	1.3	149.47	12.0			
	21.1	449	1.4	135.37	12.0			
	24.1	392	1.6	118.13	12.0			
	30.0	315	2.0	94.86	12.0			
	33.2	285	2.2	85.91	12.0			
	11.9	827	1.0	118.13	12.0	A/F 403 - 80M/4C A/F 403 - 90S/4A	43	126
	14.9	664	1.3	94.86	12.0			
	16.4	602	1.4	85.91	12.0			
	10.9	907	0.9	85.91	12.0	A403 - 90L/6B F403 - 90L/6B	47	126
	13.7	721	1.2	68.25	12.0			
	17.1	579	1.5	54.81	12.0			
	18.8	524	1.6	49.64	12.0			
	20.7	478	1.8	68.25	12.0	A403 - 90S/4A F403 - 90S/4A	43	126
	25.7	384	2.2	54.81	12.0			
	28.4	348	2.4	49.64	12.0			
	109.3	93	3.8	8.56	4.0	A501 - 90L/6B F501 - 90L/6B	37	128
	19.2	526	3.0	48.77	18.0	A502 - 90L/6B F502 - 90L/6B	64	130
	21.6	467	3.4	43.32	18.0			
	23.8	423	3.8	39.21	18.0			
	12.8	738	1.8	222.59	18.0	A503 - 80M/2B F503 - 80M/2B	55	130
	14.6	646	2.1	194.86	18.0			
	15.9	594	2.3	178.98	18.0			
	17.6	538	2.5	162.21	18.0			
	18.4	513	2.6	154.52	18.0			
	20.1	471	2.9	142.00	18.0			
	22.9	412	3.3	124.25	18.0			
	25.3	374	3.6	112.61	18.0			
	6.3	1559	1.2	222.59	18.0	A/F 503 - 80M/4C A/F 503 - 90S/4A	60	130
	7.2	1365	1.3	194.86	18.0			
	7.9	1253	1.4	178.98	18.0			
	8.7	1136	1.6	162.21	18.0			
	9.1	1082	1.7	154.52	18.0			
	9.9	994	1.8	142.00	18.0			
	11.3	870	2.1	124.25	18.0			
	12.5	789	2.3	112.61	18.0			
	14.4	685	2.6	97.80	18.0			
	16.5	598	3.0	85.33	18.0			
	17.9	551	3.3	78.64	18.0			
	19.8	499	3.6	71.27	18.0			
	5.2	1890	1.0	178.98	18.0			
5.8	1713	1.1	162.21	18.0				
6.1	1632	1.1	154.52	18.0				
6.6	1500	1.2	142.00	18.0				
7.5	1312	1.4	124.25	18.0				
8.3	1189	1.5	112.61	18.0				
9.6	1033	1.7	97.80	18.0				
11.0	901	2.0	85.33	18.0				
11.9	831	2.2	78.64	18.0				
13.1	753	2.4	71.27	18.0				
16.6	594	2.7	56.21	18.0				
3.9	2563	1.4	242.67	22.0	A603 - 90L/6B F603 - 90L/6B	92	134	
4.3	2277	1.5	215.56	22.0				
4.8	2052	1.7	194.31	22.0				
5.2	1913	1.8	181.13	22.0				
5.8	1699	2.1	160.90	22.0				
6.5	1516	2.3	143.57	22.0				
5.8	1699	2.1	242.67	22.0	A603 - 90S/4A F603 - 90S/4A	88	134	
6.5	1510	2.3	215.56	22.0				
7.3	1361	2.6	194.31	22.0				
7.8	1269	2.8	181.13	22.0				
8.8	1127	3.1	160.90	22.0				
9.8	1005	3.5	143.57	22.0				

P_1 [kW]	n_2 [Min ⁻¹]	M_2 [Nm]	f_B	i_{ges}	F_R [kN]	Typ / Type / Tipo / Type / Tipo	 Kg	 mm
1.50	144.8	99	0.9	9.81	2.8	A 202 G - 90L/4A F 202 G - 90L/4A	19	112
	162.3	88	1.0	8.75	2.8			
	181.8	79	1.0	7.81	2.8			
	201.7	71	1.2	7.04	2.8			
	221.5	65	1.3	6.41	2.8			
	247.4	58	1.3	5.74	2.8			
	275.2	52	1.6	5.16	2.8			
	306.7	47	1.5	4.63	2.8			
	338.9	42	1.5	4.19	2.8			
	372.7	38	1.5	3.81	2.8			
412.8	35	1.6	3.44	2.8				
438.3	33	1.7	3.24	2.8				
481.4	30	1.7	2.95	2.8				
518.2	28	1.7	2.74	2.8				
565.7	25	1.7	2.51	2.8				
614.7	23	1.8	2.31	2.8				
	91.1	151	0.9	10.32	4.4	A252 - 100L/6A F252 - 100L/6A	33	114
	104.2	132	1.0	9.02	4.3			
	118.5	116	1.1	7.93	4.2			
	147.7	93	1.1	6.36	4.1			
	195.9	70	1.4	4.80	3.9			
	94.9	139	1.1	30.15	4.4	A/F 252 - 80M/2C A/F 252 - 90S/2A	22	114
	106.8	123	1.2	26.79	4.3			
	118.2	111	1.3	24.19	4.3			
	124.1	106	1.4	23.04	4.2			
	141.6	93	1.6	20.19	4.2			
	154.7	85	1.8	18.49	4.1			
	167.7	79	1.8	17.05	4.0			
	191.8	69	1.9	14.91	3.9			
	205.2	64	2.0	13.94	3.9			
	239.0	55	2.0	11.97	3.7			
	277.2	48	2.2	10.32	3.6			
	317.0	42	2.3	9.02	3.5			
	360.6	37	2.6	7.93	3.4			
	449.4	29	2.7	6.36	3.2			
596.1	22	3.2	4.80	3.0				
	70.3	196	1.0	20.19	4.4	A252 - 90L/4A F252 - 90L/4A	26	114
	76.8	179	1.1	18.49	4.4			
	83.3	165	1.2	17.05	4.4			
	95.2	144	1.2	14.91	4.3			
	101.9	135	1.3	13.94	4.3			
	118.6	116	1.3	11.97	4.2			
	137.6	100	1.4	10.32	4.1			
	157.4	87	1.5	9.02	4.0			
	179.1	77	1.6	7.93	3.9			
	223.3	62	1.7	6.36	3.8			
295.8	46	2.0	4.80	3.5				
322.3	42	1.0	8.88	0.8	A301 - 80M/2C F301 - 80M/2C	17	116	
	367.7	37	1.0	7.78	0.9	A/F 301 - 80M/2C A/F 301 - 90S/2A	18	116
	462.6	29	1.3	6.18	0.8			
	512.2	26	1.4	5.58	0.8			
	563.3	24	1.4	5.08	0.8			
	670.3	20	1.7	4.27	0.8			
	784.2	17	2.0	3.65	0.7			
	905.7	15	2.0	3.16	0.7			
	1035.5	13	1.7	2.76	0.7			
	1103.9	12	1.8	2.59	0.7			
	1403.0	10	2.0	2.04	0.6			
	1947.2	7	2.7	1.47	0.6			
	254.5	55	0.9	5.58	0.9	A301 - 90L/4A F301 - 90L/4A	22	116
	279.5	50	0.9	5.08	0.9			
	332.6	42	1.1	4.27	0.9			
	389.0	36	1.3	3.65	0.9			
	449.4	31	1.3	3.16	0.8			
	514.5	27	1.1	2.76	0.8			
	548.3	25	1.2	2.59	0.8			
	696.1	20	1.3	2.04	0.8			
	966.0	14	1.7	1.47	0.7			



P₁ [kW]	n₂ [Min ⁻¹]	M₂ [Nm]	f_B	i_{ges}	F_R [kN]	Typ / Type / Tipo / Type / Tipo	Kg ~	mm
1.50	58.0	237	1.1	16.21	6.2	A302 - 100L/6A F302 - 100L/6A	36	118
	68.1	202	1.2	13.81	6.0			
	78.3	176	1.4	12.00	5.8			
	89.6	154	1.6	10.50	5.6			
	103.2	133	1.6	9.11	5.4			
	128.0	107	1.5	7.34	5.2			
	168.4	82	2.0	5.58	4.8			
	59.3	222	0.9	48.22	6.6	A302 - 80M/2C F302 - 80M/2C	24	118
	74.6	177	1.2	38.33	6.4	A/F 302 - 80M/2C A/F 302 - 90S/2A	25	118
	82.6	160	1.3	34.62	6.3			
	92.5	142	1.5	30.91	6.2			
	102.4	129	1.6	27.92	6.0			
	108.1	122	1.6	26.45	6.0			
	121.8	108	1.8	23.49	5.8			
	134.1	98	1.9	21.33	5.7			
	148.3	89	2.1	19.29	5.5			
	176.4	75	2.5	16.21	5.3			
	207.1	64	2.9	13.81	5.1			
	238.3	55	3.4	12.00	4.9			
272.5	48	3.7	10.50	4.7				
314.1	42	3.8	9.11	4.5				
389.4	34	3.5	7.34	4.3				
45.9	299	0.9	30.91	6.6	A302 - 90L/4A F302 - 90L/4A	29	118	
50.9	270	1.0	27.92	6.6				
53.7	256	1.0	26.45	6.6				
60.5	227	1.1	23.49	6.6				
66.6	207	1.2	21.33	6.5				
73.6	187	1.3	19.29	6.4				
87.6	157	1.6	16.21	6.2				
102.8	134	1.9	13.81	6.0				
118.3	116	2.2	12.00	5.8				
135.3	102	2.4	10.50	5.6				
155.9	88	2.4	9.11	5.4				
193.4	71	2.2	7.34	5.2				
254.4	54	3.0	5.58	4.8				
159.1	87	1.1	5.91	2.5				A351 - 100L/6A F351 - 100L/6A
176.3	79	1.3	5.33	2.5				
194.0	72	1.3	4.85	2.5				
231.1	60	1.5	4.07	2.5				
250.7	55	1.6	3.75	2.5				
291.7	48	1.7	3.22	2.5				
358.9	39	1.8	2.62	2.4				
433.8	32	1.9	2.17	2.3				
647.6	21	2.8	1.45	2.0				
721.4	19	2.1	1.30	2.0				
336.5	40	1.9	8.50	2.5	A/F 351 - 80M/2C A/F 351 - 90S/2A	20	120	
384.4	35	2.1	7.44	2.4				
483.9	28	2.7	5.91	2.3				
536.6	25	3.0	5.33	2.2				
589.7	23	3.1	4.85	2.1				
703.3	19	3.5	4.07	2.0				
762.7	18	3.8	3.75	2.0				
887.6	15	4.0	3.22	1.7				
167.1	83	1.2	8.50	2.5	A351 - 90L/4A F351 - 90L/4A	24	120	
190.9	73	1.4	7.44	2.5				
240.3	58	1.7	5.91	2.5				
266.4	52	1.9	5.33	2.5				
292.8	47	2.0	4.85	2.5				
349.2	40	2.3	4.07	2.5				
378.7	37	2.5	3.75	2.4				
440.7	32	2.5	3.22	2.3				
542.2	26	2.7	2.62	2.2				
655.4	21	2.8	2.17	2.1				
1089.8	13	3.1	1.30	1.8				

P_1 [kW]	n_2 [Min ⁻¹]	M_2 [Nm]	f_B	i_{ges}	F_R [kN]	Typ / Type / Tipo / Type / Tipo	 Kg	 mm
1.50	29.4	468	1.0	32.01	8.0	A352 - 100L/6A F352 - 100L/6A	41	122
	32.5	423	1.2	28.89	8.0			
	35.4	389	1.3	26.59	8.0			
	37.4	368	1.3	25.13	8.0			
	42.7	322	1.5	22.03	8.0			
	46.3	297	1.5	20.31	8.0			
	51.4	268	1.7	18.30	8.0			
	55.7	247	1.8	16.88	8.0			
	64.8	212	2.0	14.52	8.0			
	80.1	172	2.3	11.74	8.0			
	96.4	143	2.6	9.75	8.0			
	107.7	128	2.7	8.73	7.8			
	133.2	103	2.8	7.06	7.4			
	160.3	86	3.0	5.86	7.0			
		50.2	262	1.4	56.95			
	57.3	230	1.6	49.88	8.0			
	62.1	212	1.7	46.04	8.0			
	72.2	182	2.0	39.59	8.0			
	85.4	154	2.4	33.50	8.0			
	89.4	147	2.5	32.01	8.0			
	99.0	133	2.8	28.89	8.0			
	107.6	123	3.0	26.59	7.8			
	113.8	116	3.0	25.13	7.7			
	129.8	102	3.5	22.03	7.4			
	140.8	94	3.7	20.31	7.3			
	28.5	483	1.0	49.88	8.0	A352 - 90L/4A F352 - 90L/4A	34	122
	30.8	446	1.1	46.04	8.0			
	35.9	383	1.3	39.59	8.0			
	42.4	324	1.5	33.50	8.0			
	44.4	310	1.6	32.01	8.0			
	49.2	280	1.8	28.89	8.0			
	53.4	258	1.9	26.59	8.0			
	56.5	243	1.9	25.13	8.0			
	64.5	213	2.2	22.03	8.0			
	69.9	197	2.3	20.31	8.0			
	77.6	177	2.6	18.30	8.0			
	84.1	163	2.8	16.88	8.0			
	97.8	141	3.1	14.52	8.0			
	121.0	114	3.4	11.74	7.5			
	145.6	94	3.9	9.75	7.2			
	39.4	327	1.1	72.58	8.0	A/F 353 - 80M/2C A/F 353 - 90S/2A	30	122
	48.7	265	1.4	58.68	8.0			
	113.9	122	1.4	8.25	3.7	A401 - 100L/6A F401 - 100L/6A	31	124
	130.2	107	1.6	7.22	3.7			
	164.1	85	2.0	5.73	3.7			
	181.9	76	2.2	5.17	3.7			
	200.3	69	2.3	4.69	3.7			
	239.0	58	2.6	3.93	3.7			
	259.3	54	2.8	3.63	3.7			
	302.1	46	2.8	3.11	3.7			
	372.5	37	3.2	2.52	3.7			
	451.2	31	3.9	2.08	3.4			
	346.7	39	3.3	8.25	3.7	A/F 401 - 80M/2C A/F 401 - 90S/2A	20	124
	396.0	34	3.7	7.22	3.6			
	172.1	81	2.1	8.25	3.7	A401 - 90L/4A F401 - 90L/4A	24	124
	196.6	71	2.4	7.22	3.7			
	247.9	56	3.0	5.73	3.7			
	274.8	51	3.4	5.17	3.7			
	302.6	46	3.5	4.69	3.7			
	361.0	38	3.9	3.93	3.7			

P₁ [kW]	n₂ [Min ⁻¹]	M₂ [Nm]	f_B	i_{ges}	F_R [kN]	Typ / Type / Tipo / Type / Tipo	kg ~	mm			
1.50	20.7	664	1.3	45.38	12.0	A402 - 100L/6A F402 - 100L/6A	52	126			
	23.7	581	1.5	39.72	12.0						
	25.8	533	1.5	36.44	12.0						
	29.8	461	1.8	31.50	12.0						
	32.5	423	1.9	28.89	12.0						
	37.2	370	2.3	25.30	12.0						
	41.0	335	2.5	22.91	12.0						
	47.1	292	2.9	19.94	12.0						
	54.1	254	3.3	17.37	12.0						
	58.7	234	3.4	16.01	12.0						
	64.8	212	3.3	14.50	12.0						
	75.5	182	3.8	12.44	12.0						
	82.0	168	3.9	11.46	12.0						
	63.0	209	3.0	45.38	12.0				A/F 402 - 80M/2C A/F 402 - 90S/2A	41	126
	72.0	183	3.5	39.72	12.0						
	78.5	168	3.6	36.44	12.0						
	31.3	439	1.9	45.38	12.0	A402 - 90L/4A F402 - 90L/4A	45	126			
	35.8	385	2.2	39.72	12.0						
	39.0	353	2.3	36.44	12.0						
	45.1	305	2.8	31.50	12.0						
	49.2	280	2.9	28.89	12.0						
	56.1	245	3.5	25.30	12.0						
	62.0	222	3.8	22.91	12.0						
	17.2	785	1.1	54.81	12.0	A403 - 100L/6A F403 - 100L/6A	52	126			
	18.9	711	1.2	49.64	12.0						
	21.1	610	1.0	135.37	12.0	A403 - 80M/2C F403 - 80M/2C	40	126			
	24.2	532	1.2	118.13	12.0	A/F 403 - 80M/2C A/F 403 - 90S/2A	41	126			
	30.2	428	1.5	94.86	12.0						
	33.3	387	1.6	85.91	12.0						
	15.0	900	0.9	94.86	12.0	A403 - 90L/4A F403 - 90L/4A	45	126			
	16.5	815	1.0	85.91	12.0						
	20.8	647	1.3	68.25	12.0						
	25.9	520	1.6	54.81	12.0						
	28.6	471	1.8	49.64	12.0						
	41.9	308	2.1	68.25	12.0	A403 - 90S/2A F403 - 90S/2A	41	126			
	52.2	247	2.6	54.81	12.0						
	57.6	224	2.8	49.64	12.0						
	109.9	126	2.8	8.56	4.0	A501 - 100L/6A F501 - 100L/6A	42	128			
	123.7	112	3.1	7.60	4.0						
	152.4	91	3.7	6.17	4.0						
	19.3	699	2.3	48.77	18.0	A502 - 100L/6A F502 - 100L/6A	69	130			
	21.7	621	2.6	43.32	18.0						
24.0	562	2.8	39.21	18.0							
27.0	499	3.2	34.83	18.0							
29.8	452	3.5	31.57	18.0							
33.3	405	4.0	28.26	18.0							
29.1	472	3.4	48.77	18.0	A502 - 90L/4A F502 - 90L/4A				62	130	
32.8	420	3.8	43.32	18.0							
7.6	1780	1.0	124.25	18.0	A503 - 100L/6A F503 - 100L/6A	69	130				
8.3	1613	1.1	112.61	18.0							
9.6	1401	1.3	97.80	18.0							
11.0	1222	1.5	85.33	18.0							
12.0	1127	1.6	78.64	18.0							
13.2	1021	1.8	71.27	18.0							
16.7	805	2.0	56.21	18.0							

P₁ [kW]	n₂ [Min ⁻¹]	M₂ [Nm]	f_B	i_{ges}	F_R [kN]	Typ / Type / Tipo / Type / Tipo	kg ~	mm ~
1.50	12.8	1003	1.3	222.59	18.0	A/F 503 - 80M/2C A/F 503 - 90S/2A	58	130
	14.7	878	1.5	194.86	18.0			
	16.0	807	1.7	178.98	18.0			
	17.6	731	1.8	162.21	18.0			
	18.5	697	1.9	154.52	18.0			
	20.1	640	2.1	142.00	18.0			
	23.0	560	2.4	124.25	18.0			
	25.4	508	2.7	112.61	18.0			
	29.2	441	3.1	97.80	18.0			
	33.5	385	3.5	85.33	18.0			
36.4	355	3.8	78.64	18.0				
	7.3	1848	1.0	194.86	18.0	A503 - 90L/4A F503 - 90L/4A	62	130
	7.9	1697	1.1	178.98	18.0			
	8.8	1538	1.2	162.21	18.0			
	9.2	1465	1.2	154.52	18.0			
	10.0	1347	1.3	142.00	18.0			
	11.4	1178	1.5	124.25	18.0			
	12.6	1068	1.7	112.61	18.0			
	14.5	927	1.9	97.80	18.0			
	18.1	746	2.4	78.64	18.0			
	19.9	676	2.7	71.27	18.0			
25.3	533	3.0	56.21	18.0				
	3.9	3476	1.0	242.67	22.0	A603 - 100L/6A F603 - 100L/6A	97	134
	4.4	3088	1.1	215.56	22.0			
	4.8	2783	1.3	194.31	22.0			
	5.2	2595	1.3	181.13	22.0			
	5.8	2305	1.5	160.90	22.0			
	6.5	2057	1.7	143.57	22.0			
	7.0	1923	1.8	134.25	22.0			
	7.8	1734	2.0	121.02	22.0			
	9.4	1436	2.4	100.21	22.0			
	10.0	1341	2.6	93.60	22.0			
	11.1	1209	2.9	84.37	22.0			
	11.8	1146	3.1	79.98	22.0			
	13.5	1001	3.5	69.87	22.0			
	5.9	2301	1.6	242.67	22.0	A603 - 90L/4A F603 - 90L/4A	90	134
	6.6	2044	1.7	215.56	22.0			
	7.3	1843	1.9	194.31	22.0			
	7.8	1718	2.0	181.13	22.0			
	8.8	1526	2.3	160.90	22.0			
9.9	1361	2.6	143.57	22.0				
	11.8	1094	2.5	242.67	22.0	A603 - 90S/2A F603 - 90S/2A	86	134
	13.3	972	2.7	215.56	22.0			
	14.7	876	3.0	194.31	22.0			
	15.8	817	3.2	181.13	22.0			
	17.8	725	3.6	160.90	22.0			
	19.9	647	4.1	143.57	22.0			
	3.6	3727	1.3	260.15	30.0	A703 - 100L/6A F703 - 100L/6A	126	138
	4.1	3314	1.5	231.34	30.0			
	4.5	2976	1.7	207.78	30.0			
	5.0	2715	1.8	189.54	30.0			
	5.4	2480	2.0	173.11	30.0			
	6.0	2227	2.2	155.48	30.0			
	6.5	2076	2.4	144.94	30.0			
	7.3	1839	2.7	128.35	30.0			
	7.9	1701	2.9	118.75	30.0			
	8.7	1554	3.2	108.46	30.0			
	9.4	1438	3.5	100.38	30.0			
10.4	1289	3.9	89.95	30.0				

P₁ [kW]	n₂ [Min ⁻¹]	M₂ [Nm]	f_B	i_{ges}	F_R [kN]	Typ / Type / Tipo / Type / Tipo	kg ~	mm			
1.85	148.6	114	0.9	6.36	3.9	A252 - 100L/6 F252 - 100L/6	37	114			
	196.9	86	1.1	4.80	3.7						
	76.3	222	0.9	18.49	4.0	A252 - 90L/4 F252 - 90L/4	26	114			
	82.7	205	0.9	17.05	4.0						
	94.6	179	0.9	14.91	4.0						
	101.1	168	1.0	13.94	4.0						
	117.8	144	1.0	11.97	4.0						
	136.6	124	1.1	10.32	3.9						
	156.3	109	1.2	9.02	3.8						
	177.8	95	1.3	7.93	3.8						
	221.7	77	1.4	6.36	3.6						
	293.8	58	1.6	4.80	3.4						
	386.6	44	1.0	3.65	0.8	A301 - 90L/4 F301 - 90L/4	22	116			
	446.5	38	1.0	3.16	0.8						
	510.5	34	0.9	2.76	0.8						
	544.2	31	1.0	2.59	0.8						
	691.7	25	1.0	2.04	0.7						
	960.0	18	1.4	1.47	0.7						
	68.4	248	1.0	13.81	6.0	A302 - 100L/6 F302 - 100L/6	40	118			
	78.8	215	1.2	12.00	5.9						
	90.0	188	1.3	10.50	5.8						
	103.7	164	1.3	9.11	5.7						
	128.7	132	1.2	7.34	5.5						
	169.3	100	1.6	5.58	5.2						
	60.0	283	0.9	23.49	6.1				A302 - 90L/4 F302 - 90L/4	29	118
	66.1	257	1.0	21.33	6.1						
	73.1	232	1.1	19.29	6.0						
	87.0	195	1.3	16.21	5.9						
	102.1	166	1.5	13.81	5.7						
	117.5	144	1.7	12.00	5.6						
	134.3	126	1.9	10.50	5.4						
	154.8	110	1.9	9.11	5.3						
	192.1	88	1.8	7.34	5.0						
	252.6	67	2.4	5.58	4.7						
	159.9	107	0.9	5.91	2.5	A351 - 100L/6 F351 - 100L/6	35	120			
	177.3	97	1.0	5.33	2.5						
	194.8	88	1.1	4.85	2.5						
	232.2	74	1.2	4.07	2.5						
	252.0	68	1.3	3.75	2.5						
	293.5	58	1.4	3.22	2.5						
	360.8	47	1.5	2.62	2.4						
	436.2	39	1.5	2.17	2.3						
651.0	26	2.3	1.45	2.0							
725.2	24	1.7	1.30	2.0							
165.9	103	1.0	8.50	2.5	A351 - 90L/4 F351 - 90L/4	24	120				
189.5	90	1.1	7.44	2.5							
238.6	72	1.4	5.91	2.5							
264.5	65	1.5	5.33	2.5							
290.7	59	1.6	4.85	2.5							
346.4	49	1.8	4.07	2.4							
376.0	46	2.0	3.75	2.4							
437.9	39	2.0	3.22	2.3							
538.4	32	2.2	2.62	2.1							
650.8	26	2.3	2.17	2.0							
971.3	18	3.4	1.45	1.8							
1082.1	16	2.5	1.30	1.8							
32.7	519	0.9	28.89	8.0				A352 - 100L/6 F352 - 100L/6	45	122	
35.5	477	1.0	26.59	8.0							
37.6	451	1.0	25.13	8.0							
42.9	395	1.2	22.03	8.0							
46.5	365	1.3	20.31	8.0							
51.6	328	1.4	18.30	8.0							
56.0	303	1.5	16.88	8.0							
65.1	261	1.7	14.52	8.0							
80.5	211	1.9	11.74	8.0							
96.9	175	2.1	9.75	7.8							
108.2	157	2.2	8.73	7.6							
133.9	127	2.3	7.06	7.2							
161.2	105	2.5	5.86	6.9							

P_1 [kW]	n_2 [Min ⁻¹]	M_2 [Nm]	f_B	i_{ges}	F_R [kN]	Typ / Type / Tipo / Type / Tipo	 Kg	 mm
1.85	35.6	476	1.0	39.59	8.0	A352 - 90L/4 F352 - 90L/4	34	122
	42.1	403	1.2	33.50	8.0			
	44.0	385	1.3	32.01	8.0			
	48.8	348	1.4	28.89	8.0			
	53.0	320	1.5	26.59	8.0			
	56.1	302	1.6	25.13	8.0			
	64.0	265	1.8	22.03	8.0			
	69.4	244	1.9	20.31	8.0			
	77.0	220	2.1	18.30	8.0			
	83.6	203	2.2	16.88	8.0			
	97.1	175	2.5	14.52	7.7			
	120.1	141	2.8	11.74	7.4			
	144.6	117	3.2	9.75	7.0			
	161.5	105	3.2	8.73	6.8			
	199.8	85	3.4	7.06	6.4			
240.5	71	3.7	5.86	6.1				
	114.5	150	1.1	8.25	3.7	A401 - 100L/6 F401 - 100L/6	35	124
	130.8	131	1.3	7.22	3.7			
	165.0	104	1.6	5.73	3.7			
	182.9	94	1.8	5.17	3.7			
	201.4	85	1.9	4.69	3.7			
	240.3	71	2.1	3.93	3.7			
	260.7	66	2.3	3.63	3.7			
	303.8	56	2.3	3.11	3.7			
	374.4	46	2.6	2.52	3.6			
	453.6	38	3.2	2.08	3.4			
	720.0	24	3.4	1.31	2.9			
	170.9	100	1.7	8.25	3.7	A401 - 90L/4 F401 - 90L/4	24	124
	195.3	88	1.9	7.22	3.7			
	246.2	70	2.4	5.73	3.7			
	272.9	63	2.7	5.17	3.7			
	300.5	57	2.8	4.69	3.7			
	358.5	48	3.1	3.93	3.7			
	389.0	44	3.4	3.63	3.6			
	453.2	38	3.4	3.11	3.4			
	558.7	31	3.9	2.52	3.1			
	20.8	814	1.0	45.38	12.0	A402 - 100L/6 F402 - 100L/6	56	126
	23.8	713	1.2	39.72	12.0			
	25.9	654	1.2	36.44	12.0			
	30.0	565	1.5	31.50	12.0			
	32.7	518	1.5	28.89	12.0			
	37.4	454	1.9	25.30	12.0			
	41.3	411	2.1	22.91	12.0			
	47.4	358	2.4	19.94	12.0			
	54.4	312	2.7	17.37	12.0			
	59.0	287	2.8	16.01	12.0			
	65.2	260	2.7	14.50	12.0			
	75.9	223	3.1	12.44	12.0			
	82.5	206	3.2	11.46	12.0			
	102.7	165	3.6	9.20	12.0			
	113.4	150	4.0	8.33	12.0			
	31.1	546	1.6	45.38	12.0	A402 - 90L/4 F402 - 90L/4	45	126
	35.5	478	1.8	39.72	12.0			
	38.7	438	1.8	36.44	12.0			
	44.8	379	2.2	31.50	12.0			
	48.8	348	2.3	28.89	12.0			
	55.7	304	2.8	25.30	12.0			
	61.5	276	3.1	22.91	12.0			
	70.7	240	3.5	19.94	12.0			
	81.2	209	4.0	17.37	12.0			
	97.2	174	4.0	14.50	12.0			
	28.4	585	1.5	49.64	12.0	A403 - 100L/6 F403 - 100L/6	56	126
	20.7	804	1.1	68.25	12.0	A403 - 90L/4 F403 - 90L/4	45	126
	25.7	646	1.3	54.81	12.0			
	28.4	585	1.5	49.64	12.0			

P₁ [kW]	n₂ [Min ⁻¹]	M₂ [Nm]	f_B	i_{ges}	F_R [kN]	Typ / Type / Tipo / Type / Tipo	kg ~	mm
1.85	110.5	154	2.3	8.56	4.0	A501 - 100L/6 F501 - 100L/6	46	128
	124.3	136	2.6	7.60	4.0			
	153.2	111	3.1	6.17	4.0			
	168.3	101	3.3	5.62	4.0			
	199.6	85	3.8	4.73	4.0			
	164.8	104	3.4	8.56	4.0	A501 - 90L/4 F501 - 90L/4	35	128
	185.5	92	3.8	7.60	4.0			
	19.4	875	1.8	48.77	18.0	A502 - 100L/6 F502 - 100L/6	73	130
	21.8	778	2.1	43.32	18.0			
	24.1	704	2.3	39.21	18.0			
	27.1	625	2.6	34.83	18.0			
	29.9	567	2.8	31.57	18.0			
	33.4	507	3.2	28.26	18.0			
	35.0	484	3.3	26.98	18.0			
	40.8	415	3.9	23.14	18.0			
	28.9	587	2.7	48.77	18.0	A502 - 90L/4 F502 - 90L/4	62	130
	32.5	521	3.1	43.32	18.0			
	36.0	472	3.4	39.21	18.0			
	40.5	419	3.8	34.83	18.0			
	9.7	1719	1.0	97.80	18.0	A503 - 100L/6 F503 - 100L/6	73	130
	11.1	1500	1.2	85.33	18.0			
	12.0	1382	1.3	78.64	18.0			
	13.3	1253	1.4	71.27	18.0			
	16.8	988	1.6	56.21	18.0			
	8.7	1911	0.9	162.21	18.0	A503 - 90L/4 F503 - 90L/4	62	130
	9.1	1820	1.0	154.52	18.0			
	9.9	1673	1.1	142.00	18.0			
	11.3	1463	1.2	124.25	18.0			
	12.5	1326	1.4	112.61	18.0			
	14.4	1152	1.6	97.80	18.0			
	16.5	1005	1.8	85.33	18.0			
	17.9	926	1.9	78.64	18.0			
	19.8	839	2.1	71.27	18.0			
	25.1	662	2.4	56.21	18.0			
	18.6	914	3.6	50.91	22.0	A602 - 100L/6 F602 - 100L/6	101	134
	20.9	813	4.1	45.27	22.0			
	4.4	3788	0.9	215.56	22.0	A603 - 100L/6 F603 - 100L/6	101	134
	4.9	3415	1.0	194.31	22.0			
	5.2	3183	1.1	181.13	22.0			
	5.9	2828	1.2	160.90	22.0			
	6.6	2523	1.4	143.57	22.0			
	7.0	2359	1.5	134.25	22.0			
	7.8	2127	1.6	121.02	22.0			
	9.4	1761	2.0	100.21	22.0			
	10.1	1645	2.1	93.60	22.0			
	11.2	1483	2.4	84.37	22.0			
11.8	1406	2.5	79.98	22.0				
13.5	1228	2.9	69.87	22.0				
5.8	2858	1.3	242.67	22.0	A603 - 90L/4 F603 - 90L/4			
6.5	2539	1.4	215.56	22.0				
7.3	2289	1.5	194.31	22.0				
7.8	2133	1.6	181.13	22.0				
8.8	1895	1.8	160.90	22.0				
9.8	1691	2.1	143.57	22.0				
3.6	4572	1.1	260.15	30.0	A703 - 100L/6 F703 - 100L/6	131	138	
4.1	4066	1.2	231.34	30.0				
4.5	3652	1.4	207.78	30.0				
5.0	3331	1.5	189.54	30.0				
5.5	3042	1.6	173.11	30.0				
6.1	2732	1.8	155.48	30.0				
6.5	2547	2.0	144.94	30.0				
7.4	2256	2.2	128.35	30.0				
8.0	2087	2.4	118.75	30.0				
8.7	1906	2.6	108.46	30.0				
9.4	1764	2.8	100.38	30.0				
10.5	1581	3.2	89.95	30.0				
11.3	1465	3.4	83.35	30.0				
12.8	1295	3.9	73.70	30.0				

P_1 [kW]	n_2 [Min ⁻¹]	M_2 [Nm]	f_B	i_{ges}	F_R [kN]	Typ / Type / Tipo / Type / Tipo	Kg	mm
2.20	136.7	148	0.9	10.32	3.6	A252 - 100L/4A F252 - 100L/4A	34	114
	156.3	129	1.0	9.02	3.6			
	177.8	113	1.1	7.93	3.6			
	221.7	91	1.2	6.36	3.5			
	293.8	69	1.4	4.80	3.3			
	141.6	136	1.1	20.19	3.7	A252 - 90L/2A F252 - 90L/2A	27	114
	154.7	125	1.2	18.49	3.7			
	167.7	115	1.2	17.05	3.6			
	191.8	101	1.3	14.91	3.6			
	205.2	94	1.4	13.94	3.6			
	239.0	81	1.3	11.97	3.5			
	277.2	70	1.5	10.32	3.4			
	317.0	61	1.6	9.02	3.3			
	360.6	54	1.7	7.93	3.2			
	449.4	43	1.8	6.36	3.1			
596.1	32	2.2	4.80	2.9				
670.3	29	1.1	4.27	0.7	A301 - 90L/2A F301 - 90L/2A	30	116	
784.2	25	1.3	3.65	0.7				
905.7	22	1.4	3.16	0.7				
1035.5	19	1.2	2.76	0.6				
1103.9	18	1.3	2.59	0.6				
1403.0	14	1.3	2.04	0.6				
1947.2	10	1.8	1.47	0.6				
73.1	276	0.9	19.29	5.6	A302 - 100L/4A F302 - 100L/4A	37	118	
87.0	232	1.1	16.21	5.6				
102.1	198	1.3	13.81	5.5				
117.5	172	1.5	12.00	5.3				
134.3	150	1.6	10.50	5.2				
154.8	130	1.6	9.11	5.1				
192.1	105	1.5	7.34	4.9				
252.7	80	2.0	5.58	4.6				
169.3	119	1.3	5.58	5.0	A302 - 112M/6A F302 - 112M/6A	45	118	
102.4	189	1.1	27.92	5.5	A302 - 90L/2A F302 - 90L/2A	30	118	
108.1	179	1.1	26.45	5.5				
121.7	159	1.2	23.49	5.4				
134.1	144	1.3	21.33	5.3				
148.2	130	1.4	19.29	5.2				
176.4	110	1.7	16.21	5.0				
207.1	93	2.0	13.81	4.8				
238.3	81	2.3	12.00	4.7				
272.5	71	2.5	10.50	4.5				
314.1	62	2.6	9.11	4.4				
389.4	50	2.4	7.34	4.1				
512.4	38	3.2	5.58	3.9				
238.6	85	1.2	5.91	2.5				A351 - 100L/4A F351 - 100L/4A
264.5	77	1.3	5.33	2.5				
290.7	70	1.4	4.85	2.4				
346.4	59	1.5	4.07	2.3				
376.0	54	1.7	3.75	2.3				
437.9	47	1.7	3.22	2.2				
538.2	38	1.8	2.62	2.1				
649.8	31	1.9	2.17	2.0				
972.4	21	2.9	1.45	1.8				
1084.6	19	2.1	1.30	1.7				
252.0	81	1.1	3.75	2.5	A351 - 112M/6A F351 - 112M/6A	40	120	
293.3	69	1.2	3.22	2.4				
360.8	56	1.2	2.62	2.3				
436.2	47	1.3	2.17	2.2				
651.0	31	1.9	1.45	2.0				
725.2	28	1.4	1.30	1.9				

P₁ [kW]	n₂ [Min ⁻¹]	M₂ [Nm]	f_B	i_{ges}	F_R [kN]	Typ / Type / Tipo / Type / Tipo	kg ~	mm
2.20	336.5	59	1.3	8.50	2.4	A351 - 90L/2A F351 - 90L/2A	25	120
	384.2	51	1.5	7.44	2.3			
	484.0	41	1.8	5.91	2.2			
	536.3	37	2.0	5.33	2.1			
	590.2	33	2.1	4.85	2.1			
	703.3	28	2.4	4.07	2.0			
	762.7	26	2.6	3.75	1.9			
	887.6	22	2.7	3.22	1.8			
	1092.0	18	2.9	2.62	1.7			
	1320.0	15	3.0	2.17	1.6			
2194.9	9	3.3	1.30	1.4				
	44.0	458	1.1	32.01	8.0	A352 - 100L/4A F352 - 100L/4A	42	122
	48.8	413	1.2	28.89	8.0			
	53.0	380	1.3	26.59	8.0			
	56.1	359	1.3	25.13	8.0			
	64.0	315	1.5	22.03	8.0			
	69.4	291	1.6	20.31	8.0			
	77.0	262	1.8	18.30	7.9			
	83.5	241	1.9	16.88	7.8			
	97.1	208	2.1	14.52	7.5			
	120.1	168	2.3	11.74	7.2			
	144.6	139	2.7	9.75	6.9			
	161.5	125	2.7	8.73	6.7			
	199.8	101	2.9	7.06	6.3			
	240.5	84	3.1	5.86	6.0			
	51.6	391	1.2	18.30	8.0	A352 - 112M/6A F352 - 112M/6A	50	122
	56.0	360	1.2	16.88	8.0			
	65.1	310	1.4	14.52	8.0			
	80.5	250	1.6	11.74	7.8			
	96.9	208	1.8	9.75	7.6			
	108.2	186	1.8	8.73	7.4			
	133.9	151	1.9	7.06	7.1			
	161.2	125	2.1	5.86	6.7			
	57.3	337	1.1	49.88	8.0	A352 - 90L/2A F352 - 90L/2A	35	122
	62.1	311	1.2	46.04	8.0			
	72.2	268	1.4	39.59	8.0			
	85.4	226	1.6	33.50	7.8			
	89.4	216	1.7	32.01	7.7			
	99.0	195	1.9	28.89	7.6			
	107.6	180	2.0	26.59	7.4			
	113.8	170	2.1	25.13	7.3			
	129.8	149	2.4	22.03	7.1			
	140.8	137	2.5	20.31	7.0			
	156.3	124	2.8	18.30	6.8			
	169.5	114	3.0	16.88	6.7			
	197.0	98	3.3	14.52	6.4			
	243.7	79	3.7	11.74	6.1			
	170.9	119	1.4	8.25	3.7	A401 - 100L/4A F401 - 100L/4A	32	124
	195.3	104	1.6	7.22	3.7			
	246.1	83	2.1	5.73	3.7			
	272.7	75	2.3	5.17	3.7			
	300.6	68	2.4	4.69	3.7			
	358.5	57	2.6	3.93	3.6			
	389.0	52	2.9	3.63	3.5			
	453.2	45	2.9	3.11	3.4			
	558.7	36	3.3	2.52	3.2			
	676.8	30	4.0	2.08	2.9			
	165.0	124	1.4	5.73	3.7	A401 - 112M/6A F401 - 112M/6A	40	124
	182.9	111	1.5	5.17	3.7			
	201.4	101	1.6	4.69	3.7			
	240.3	85	1.8	3.93	3.7			
	260.7	78	1.9	3.63	3.7			
	303.8	67	1.9	3.11	3.7			
	374.4	54	2.2	2.52	3.6			
	453.6	45	2.7	2.08	3.4			
	720.0	28	2.8	1.31	3.0			

P_1 [kW]	n_2 [Min ⁻¹]	M_2 [Nm]	f_B	i_{ges}	F_R [kN]	Typ / Type / Tipo / Type / Tipo	Kg	mm
2.20	346.7	57	2.2	8.25	3.7	A401 - 90L/2A F401 - 90L/2A	25	124
	396.0	50	2.6	7.22	3.5			
	499.4	40	3.2	5.73	3.3			
	553.5	36	3.6	5.17	3.2			
	609.5	32	3.7	4.69	3.1			
	31.1	649	1.3	45.38	12.0	A402 - 100L/4A F402 - 100L/4A	53	126
	35.5	568	1.5	39.72	12.0			
	38.7	521	1.5	36.44	12.0			
	44.8	451	1.9	31.50	12.0			
	48.8	413	1.9	28.89	12.0			
	55.7	362	2.3	25.30	12.0			
	61.5	328	2.6	22.91	12.0			
	70.7	285	3.0	19.94	12.0			
	81.2	249	3.3	17.37	12.0			
	88.1	229	3.5	16.01	12.0			
97.2	207	3.4	14.50	12.0				
113.3	178	3.9	12.44	12.0				
123.1	164	4.0	11.46	12.0				
30.0	672	1.3	31.50	12.0	A402 - 112M/6A F402 - 112M/6A	56	126	
32.7	617	1.3	28.89	12.0				
37.4	540	1.6	25.30	12.0				
41.3	489	1.7	22.91	12.0				
47.4	426	2.0	19.94	12.0				
54.4	371	2.2	17.37	12.0				
59.0	342	2.3	16.01	12.0				
65.2	309	2.3	14.50	12.0				
75.9	266	2.6	12.44	12.0				
82.5	245	2.7	11.46	12.0				
102.7	196	3.1	9.20	12.0				
113.4	178	3.4	8.33	12.0				
130.9	154	3.6	7.22	12.0				
63.0	307	2.1	45.38	12.0	A402 - 90L/2A F402 - 90L/2A	46	126	
72.0	268	2.4	39.72	12.0				
78.5	246	2.4	36.44	12.0				
90.8	213	3.0	31.50	12.0				
99.0	195	3.1	28.89	12.0				
113.1	171	3.7	25.30	12.0				
124.8	155	4.1	22.91	12.0				
25.7	768	1.1	54.81	12.0	A403 - 100L/4A F403 - 100L/4A	53	126	
28.4	695	1.2	49.64	12.0				
33.3	568	1.1	85.91	12.0	A403 - 90L/2A F403 - 90L/2A	46	126	
41.9	451	1.4	68.25	12.0				
52.2	362	1.8	54.81	12.0				
57.6	328	1.9	49.64	12.0				
164.8	124	2.8	8.56	4.0	A501 - 100L/4A F501 - 100L/4A	43	128	
185.5	110	3.2	7.60	4.0				
228.6	89	3.8	6.17	4.0				
110.5	185	1.9	8.56	4.0	A501 - 112M/6A F501 - 112M/6A	51	128	
124.3	164	2.1	7.60	4.0				
153.2	133	2.6	6.17	4.0				
168.3	121	2.7	5.62	4.0				
199.6	102	3.1	4.73	4.0				
232.8	88	3.7	4.06	4.0				
250.1	81	3.8	3.78	4.0				
28.9	698	2.3	48.77	18.0	A502 - 100L/4A F502 - 100L/4A	70	130	
32.5	620	2.6	43.32	18.0				
36.0	561	2.9	39.21	18.0				
40.5	498	3.2	34.83	18.0				
44.7	452	3.5	31.57	18.0				
49.9	404	4.0	28.26	18.0				

P₁ [kW]	n₂ [Min ⁻¹]	M₂ [Nm]	f_B	i_{ges}	F_R [kN]	Typ / Type / Tipo / Type / Tipo	kg ~	mm			
2.20	19.4	1041	1.5	48.77	18.0	A502 - 112M/6A F502 - 112M/6A	78	130			
	21.8	925	1.7	43.32	18.0						
	24.1	837	1.9	39.21	18.0						
	27.1	743	2.2	34.83	18.0						
	29.9	674	2.4	31.57	18.0						
	33.4	603	2.7	28.26	18.0						
	35.0	576	2.8	26.98	18.0						
	40.8	494	3.2	23.14	18.0						
	43.6	463	3.5	21.69	18.0						
	48.1	420	3.8	19.66	18.0						
	50.2	401	3.7	18.81	18.0						
	58.6	330	3.6	48.77	18.0				A502 - 90L/2A F502 - 90L/2A	63	130
	11.3	1740	1.0	124.25	18.0				A503 - 100L/4A F503 - 100L/4A	70	130
	12.5	1577	1.1	112.61	18.0						
	14.4	1370	1.3	97.80	18.0						
	16.5	1195	1.5	85.33	18.0						
	17.9	1101	1.6	78.64	18.0						
	19.8	998	1.8	71.27	18.0						
	25.1	787	2.0	56.21	18.0						
	13.3	1490	1.2	71.27	18.0	A503 - 112M/6A F503 - 112M/6A	78	130			
	16.8	1175	1.4	56.21	18.0						
	14.7	1288	1.0	194.86	18.0	A503 - 90L/2A F503 - 90L/2A	63	130			
	16.0	1183	1.1	178.98	18.0						
	17.6	1072	1.3	162.21	18.0						
	18.5	1022	1.3	154.52	18.0						
	20.1	939	1.4	142.00	18.0						
	23.0	821	1.6	124.25	18.0						
	25.4	745	1.8	112.61	18.0						
	29.2	647	2.1	97.80	18.0						
	33.5	564	2.4	85.33	18.0						
	36.4	520	2.6	78.64	18.0						
	40.1	471	2.9	71.27	18.0						
	50.9	372	3.2	56.21	18.0						
	113.9	179	3.6	8.30	5.0				A601 - 112M/6A F601 - 112M/6A	63	132
	126.8	161	4.0	7.45	5.0						
	18.6	1087	3.0	50.91	22.0	A602 - 112M/6A F602 - 112M/6A	106	134			
	20.9	966	3.4	45.27	22.0						
	23.2	871	3.8	40.81	22.0						
	24.9	811	3.5	38.00	22.0						
	5.8	3399	1.1	242.67	22.0	A603 - 100L/4A F603 - 100L/4A	98	134			
	6.5	3019	1.2	215.56	22.0						
	7.3	2722	1.3	194.31	22.0						
	7.8	2537	1.4	181.13	22.0						
	8.8	2254	1.6	160.90	22.0						
	9.8	2011	1.7	143.57	22.0						
	10.5	1880	1.9	134.25	22.0						
	11.7	1695	2.1	121.02	22.0						
14.1	1404	2.5	100.21	22.0							
15.1	1311	2.7	93.60	22.0							
16.7	1182	3.0	84.37	22.0							
17.6	1120	3.1	79.98	22.0							
20.2	979	3.6	69.87	22.0							
6.6	3000	1.2	143.57	22.0	A603 - 112M/6A F603 - 112M/6A	106	134				
7.0	2806	1.2	134.25	22.0							
7.8	2529	1.4	121.02	22.0							
9.4	2094	1.7	100.21	22.0							
10.1	1956	1.8	93.60	22.0							
11.2	1763	2.0	84.37	22.0							
11.8	1672	2.1	79.98	22.0							
13.5	1460	2.4	69.87	22.0							
11.8	1604	1.7	242.67	22.0	A603 - 90L/2A F603 - 90L/2A	91	134				
13.3	1425	1.8	215.56	22.0							
14.7	1285	2.0	194.31	22.0							
15.8	1198	2.2	181.13	22.0							
17.8	1064	2.5	160.90	22.0							
19.9	949	2.8	143.57	22.0							



P₁ [kW]	n₂ [Min ⁻¹]	M₂ [Nm]	f_B	i_{ges}	F_R [kN]	Typ / Type / Tipo / Type / Tipo	Kg ~	mm	
2.20	5.4	3644	1.4	260.15	30.0	A703 - 100L/4A F703 - 100L/4A	128	138	
	6.1	3240	1.5	231.34	30.0				
	6.8	2910	1.7	207.78	30.0				
	7.4	2655	1.9	189.54	30.0				
	8.1	2425	2.1	173.11	30.0				
	9.1	2178	2.3	155.48	30.0				
	9.7	2030	2.5	144.94	30.0				
	11.0	1798	2.8	128.35	30.0				
	11.9	1663	3.0	118.75	30.0				
	13.0	1519	3.3	108.46	30.0				
	14.0	1406	3.6	100.38	30.0				
	15.7	1260	4.0	89.95	30.0				
		4.5	4342	1.2	207.78	30.0	A703 - 112M/6A F703 - 112M/6A	135	138
		5.0	3961	1.3	189.54	30.0			
		5.5	3618	1.4	173.11	30.0			
		6.1	3249	1.5	155.48	30.0			
		6.5	3029	1.7	144.94	30.0			
		7.4	2682	1.9	128.35	30.0			
		8.0	2482	2.0	118.75	30.0			
		8.7	2267	2.2	108.46	30.0			
	9.4	2098	2.4	100.38	30.0				
	10.5	1880	2.7	89.95	30.0				
	11.3	1742	2.9	83.35	30.0				
	12.8	1540	3.2	73.70	30.0				
	14.0	1407	3.6	67.31	30.0				
3.00	280.2	94	1.1	10.32	3.1	A252 - 100L/2A F252 - 100L/2A	34	114	
	320.3	82	1.2	9.02	3.1				
	364.4	72	1.3	7.93	3.0				
	454.1	58	1.4	6.36	2.9				
	602.3	44	1.6	4.80	2.7				
	293.8	94	1.0	4.80	3.1	A252 - 100L/4B F252 - 100L/4B	37	114	
	149.8	176	1.1	19.29	4.8	A302 - 100L/2A F302 - 100L/2A	37	118	
	178.2	148	1.3	16.21	4.7				
	209.3	126	1.5	13.81	4.6				
	240.8	109	1.7	12.00	4.4				
	275.4	96	1.9	10.50	4.3				
	317.4	83	1.9	9.11	4.2				
	393.5	67	1.8	7.34	4.0				
	517.8	51	2.4	5.58	3.7				
	102.1	269	0.9	13.81	4.9	A302 - 100L/4B F302 - 100L/4B	40	118	
	117.5	234	1.1	12.00	4.8				
	134.3	205	1.2	10.50	4.8				
	154.8	178	1.2	9.11	4.7				
	192.1	143	1.1	7.34	4.6				
	252.7	109	1.5	5.58	4.3				
171.1	161	1.0	5.58	4.7	A302 - 132S/6B F302 - 132S/6B	61	118		
489.1	55	1.4	5.91	2.1	A351 - 100L/2A F351 - 100L/2A	32	120		
542.2	50	1.5	5.33	2.0					
595.9	45	1.6	4.85	2.0					
710.1	38	1.8	4.07	1.9					
770.7	35	1.9	3.75	1.9					
897.5	30	2.0	3.22	1.8					
1103.1	24	2.2	2.62	1.7					
1331.8	20	2.2	2.17	1.6					
1993.1	14	3.3	1.45	1.4					
2223.1	12	2.5	1.30	1.4					
264.5	105	1.0	5.33	2.3	A351 - 100L/4B F351 - 100L/4B	35	120		
290.7	96	1.0	4.85	2.3					
346.4	80	1.1	4.07	2.2					
376.0	74	1.2	3.75	2.2					
437.9	63	1.3	3.22	2.1					
538.2	52	1.4	2.62	2.0					
649.8	43	1.4	2.17	1.9					
972.4	29	2.1	1.45	1.7					
1084.6	26	1.6	1.30	1.7					

P₁ [kW]	n₂ [Min ⁻¹]	M₂ [Nm]	f_B	i_{ges}	F_R [kN]	Typ / Type / Tipo / Type / Tipo	kg ~	mm
3.00	364.6	76	0.9	2.62	2.2	A351 - 112M/6 F351 - 112M/6	42	120
	440.8	63	1.0	2.17	2.1			
	657.9	42	1.4	1.45	1.9			
	732.9	38	1.1	1.30	1.9			
	90.3	292	1.3	32.01	7.2	A352 - 100L/2A F352 - 100L/2A	42	122
	100.0	263	1.4	28.89	7.1			
	108.7	243	1.5	26.59	7.0			
	115.0	229	1.5	25.13	6.9			
	131.2	201	1.8	22.03	6.8			
	142.3	185	1.9	20.31	6.6			
157.9	167	2.1	18.30	6.5				
171.3	154	2.2	16.88	6.4				
199.1	132	2.4	14.52	6.2				
246.2	107	2.7	11.74	5.9				
296.4	89	3.1	9.75	5.6				
331.0	80	3.2	8.73	5.4				
409.5	64	3.4	7.06	5.1				
492.9	53	3.6	5.86	4.9				
53.0	519	0.9	26.59	7.4	A352 - 100L/4B F352 - 100L/4B	45	122	
56.1	490	1.0	25.13	7.4				
64.0	430	1.1	22.03	7.4				
69.4	396	1.2	20.31	7.3				
77.0	357	1.3	18.30	7.2				
83.5	329	1.4	16.88	7.2				
97.1	283	1.5	14.52	7.0				
120.1	229	1.7	11.74	6.8				
144.6	190	1.9	9.75	6.5				
161.5	170	2.0	8.73	6.4				
199.7	138	2.1	7.06	6.1				
240.6	114	2.3	5.86	5.8				
56.6	486	0.9	16.88	7.4	A352 - 112M/6 F352 - 112M/6	52	122	
65.8	418	1.0	14.52	7.3				
81.3	338	1.2	11.74	7.2				
97.9	281	1.3	9.75	7.0				
109.4	251	1.4	8.73	6.9				
135.3	203	1.4	7.06	6.7				
163.0	169	1.5	5.86	6.4				
350.3	77	1.7	8.25	3.6	A401 - 100L/2A F401 - 100L/2A	32	124	
400.3	67	1.9	7.22	3.4				
504.4	53	2.4	5.73	3.2				
559.0	48	2.6	5.17	3.1				
616.2	44	2.7	4.69	3.0				
735.4	37	3.1	3.93	2.9				
798.3	34	3.3	3.62	2.8				
929.3	29	3.4	3.11	2.7				
1146.8	23	3.8	2.52	2.5				
170.9	163	1.0	8.25	3.7				A401 - 100L/4B F401 - 100L/4B
195.3	142	1.2	7.22	3.7				
246.1	113	1.5	5.73	3.7				
272.7	102	1.7	5.17	3.7				
300.6	92	1.7	4.69	3.7				
358.8	77	1.9	3.93	3.5				
389.5	71	2.1	3.62	3.4				
453.4	61	2.1	3.11	3.3				
559.5	50	2.4	2.52	3.1				
676.8	41	2.9	2.08	2.9				
1074.3	26	3.1	1.31	2.6				
166.7	167	1.0	5.73	3.7	A401 - 112M/6 F401 - 112M/6	41	124	
184.8	150	1.1	5.17	3.7				
203.5	137	1.2	4.69	3.7				
242.8	114	1.3	3.93	3.7				
263.4	105	1.4	3.63	3.7				
307.0	91	1.4	3.11	3.7				
378.4	73	1.6	2.52	3.6				
458.4	61	2.0	2.08	3.3				
727.6	38	2.1	1.31	3.0				

P_1 [kW]	n_2 [Min ⁻¹]	M_2 [Nm]	f_B	i_{ges}	F_R [kN]	Typ / Type / Tipo / Type / Tipo	Kg	mm
3.00	63.7	414	1.5	45.38	12.0	A402 - 100L/2A F402 - 100L/2A	53	126
	72.8	362	1.8	39.72	12.0			
	79.3	332	1.8	36.44	12.0			
	91.7	287	2.2	31.50	12.0			
	100.0	263	2.3	28.89	12.0			
	114.2	231	2.8	25.30	12.0			
	126.1	209	3.1	22.91	12.0			
	144.9	182	3.5	19.94	12.0			
	166.4	158	3.9	17.37	11.7			
	180.5	146	4.1	16.01	11.4			
199.3	132	4.0	14.50	11.1				
	31.1	885	1.0	45.38	12.0	A402 - 100L/4B F402 - 100L/4B	56	126
	35.5	775	1.1	39.72	12.0			
	38.7	711	1.1	36.44	12.0			
	44.8	614	1.4	31.50	12.0			
	48.8	564	1.4	28.89	12.0			
	55.7	494	1.7	25.30	12.0			
	61.5	447	1.9	22.91	12.0			
	70.7	389	2.2	19.94	12.0			
	81.2	339	2.4	17.37	12.0			
	88.1	312	2.6	16.01	12.0			
	97.2	283	2.5	14.50	12.0			
	113.3	243	2.9	12.44	12.0			
	123.1	224	2.9	11.46	12.0			
	153.2	179	3.3	9.20	11.8			
169.2	163	3.7	8.33	11.5				
195.3	141	3.9	7.22	11.1				
	30.3	907	0.9	31.50	12.0	A402 - 112M/6 F402 - 112M/6	62	126
	33.1	832	1.0	28.89	12.0			
	37.8	729	1.2	25.30	12.0	A/F 402 - 112M/6 A/F 402 - 132S/6B	76	126
	41.7	660	1.3	22.91	12.0			
	47.9	574	1.5	19.94	12.0			
	55.0	500	1.7	17.37	12.0			
	59.6	461	1.7	16.01	12.0			
	65.9	418	1.7	14.50	12.0			
	76.7	358	2.0	12.44	12.0			
	83.3	330	2.0	11.46	12.0			
	103.8	265	2.3	9.20	12.0			
	114.6	240	2.5	8.33	12.0			
	132.3	208	2.6	7.22	12.0			
	164.7	167	3.3	5.80	11.8			
181.9	151	3.3	5.25	11.5				
	52.7	489	1.3	54.81	12.0	A403 - 100L/2A F403 - 100L/2A	53	126
	58.2	443	1.4	49.64	12.0			
	337.6	80	3.3	8.56	4.0	A501 - 100L/2A F501 - 100L/2A	43	128
	380.3	71	3.7	7.60	4.0			
	164.7	169	2.1	8.56	4.0	A501 - 100L/4B F501 - 100L/4B	46	128
	185.5	150	2.3	7.60	4.0			
	228.6	122	2.8	6.17	4.0			
	251.1	111	3.0	5.62	4.0			
	297.9	93	3.4	4.73	4.0			
	111.6	249	1.4	8.56	4.0	A/F 501 - 112M/6 A/F 501 - 132S/6B	66	128
	125.7	221	1.6	7.60	4.0			
	154.9	179	1.9	6.17	4.0			
	170.1	163	2.0	5.62	4.0			
	201.8	138	2.3	4.73	4.0			
	235.3	118	2.7	4.06	4.0			
	252.8	110	2.8	3.78	4.0			
	289.4	96	3.2	3.30	4.0			
	369.7	75	3.7	2.58	4.0			
	59.3	445	2.7	48.77	18.0	A502 - 100L/2A F502 - 100L/2A	70	130
	66.7	395	3.0	43.32	18.0			
	73.7	358	3.4	39.21	18.0			
	83.0	318	3.8	34.83	17.6			

P₁ [kW]	n₂ [Min ⁻¹]	M₂ [Nm]	f_B	i_{ges}	F_R [kN]	Typ / Type / Tipo / Type / Tipo	kg ~	mm			
3.00	28.9	951	1.7	48.77	18.0	A502 - 100L/4B F502 - 100L/4B	73	130			
	32.5	845	1.9	43.32	18.0						
	36.0	765	2.1	39.21	18.0						
	40.5	679	2.4	34.83	18.0						
	44.7	616	2.6	31.57	18.0						
	49.9	551	2.9	28.26	18.0						
	52.3	526	3.0	26.98	18.0						
	60.9	451	3.5	23.14	18.0						
	65.0	423	3.8	21.69	18.0						
	19.6	1404	1.1	48.77	18.0				A/F 502 - 112M/6 A/F 502 - 132S/6B	93	130
	22.0	1248	1.3	43.32	18.0						
	24.4	1129	1.4	39.21	18.0						
	27.4	1003	1.6	34.83	18.0						
	30.3	909	1.8	31.57	18.0						
	33.8	814	2.0	28.26	18.0						
	35.4	777	2.1	26.98	18.0						
	41.3	666	2.4	23.14	18.0						
	44.0	625	2.6	21.69	18.0						
	48.6	566	2.8	19.66	18.0						
	50.8	542	2.8	18.81	18.0						
	56.6	486	3.1	16.86	18.0						
	63.1	436	3.4	15.13	18.0						
	69.7	395	3.5	13.71	18.0						
	85.2	323	3.4	11.20	17.5	A502 - 132S/6B F502 - 132S/6B	93	130			
	106.0	259	3.5	9.01	16.5						
	117.0	235	3.4	8.16	16.1						
	126.5	217	3.7	7.55	15.7						
	23.3	1109	1.2	124.25	18.0	A503 - 100L/2A F503 - 100L/2A	70	130			
	25.7	1005	1.3	112.61	18.0						
	29.5	873	1.5	97.80	18.0						
	33.9	761	1.8	85.33	18.0						
	36.7	702	1.9	78.64	18.0						
	40.5	636	2.1	71.27	18.0						
	51.4	501	2.4	56.21	18.0						
	14.4	1868	1.0	97.80	18.0	A503 - 100L/4B F503 - 100L/4B	73	130			
	16.5	1630	1.1	85.33	18.0						
	17.9	1502	1.2	78.64	18.0						
	19.8	1361	1.3	71.27	18.0						
	25.1	1074	1.5	56.21	18.0						
	17.0	1585	1.0	56.21	18.0	A503 - 132S/6B F503 - 132S/6B	93	130			
	169.9	164	4.0	8.30	5.0	A601 - 100L/4B F601 - 100L/4B	58	132			
	115.1	242	2.7	8.30	5.0	A/F 601 - 112M/6 A/F 601 - 132S/6B	78	132			
128.1	217	3.0	7.45	5.0							
155.2	179	3.6	6.15	5.0							
183.7	151	4.1	5.20	5.0							
27.7	993	3.3	50.91	22.0	A602 - 100L/4B F602 - 100L/4B	101	134				
31.1	883	3.7	45.27	22.0							
37.1	741	3.8	38.00	22.0							
18.8	1466	2.3	50.91	22.0	A/F 602 - 112M/6 A/F 602 - 132S/6B	121	134				
21.1	1304	2.5	45.27	22.0							
23.4	1175	2.8	40.81	22.0							
25.1	1094	2.6	38.00	22.0							
28.3	973	3.3	33.79	22.0							
31.5	874	3.7	30.35	22.0							
33.7	817	4.0	28.36	22.0							



P_1 [kW]	n_2 [Min ⁻¹]	M_2 [Nm]	f_B	i_{ges}	F_R [kN]	Typ / Type / Tipo / Type / Tipo	Kg	mm
3.00	11.9	2165	1.2	242.67	22.0	A603 - 100L/2A F603 - 100L/2A	98	134
	13.4	1923	1.4	215.56	22.0			
	14.9	1734	1.5	194.31	22.0			
	16.0	1616	1.6	181.13	22.0			
	18.0	1436	1.8	160.90	22.0			
	20.1	1281	2.0	143.57	22.0			
	21.5	1198	2.2	134.25	22.0			
	23.9	1080	2.4	121.02	22.0			
	28.8	894	2.9	100.21	22.0			
	30.9	835	3.1	93.60	22.0			
34.3	753	3.5	84.37	22.0				
36.1	714	3.7	79.98	22.0				
	7.3	3711	0.9	194.31	22.0	A603 - 100L/4B F603 - 100L/4B	101	134
	7.8	3460	1.0	181.13	22.0			
	8.8	3073	1.1	160.90	22.0			
	9.8	2742	1.3	143.57	22.0			
	10.5	2564	1.4	134.25	22.0			
	11.7	2311	1.5	121.02	22.0			
	14.1	1914	1.8	100.21	22.0			
	15.1	1788	2.0	93.60	22.0			
	16.7	1611	2.2	84.37	22.0			
	17.6	1528	2.3	79.98	22.0			
	20.2	1334	2.6	69.87	22.0			
	7.1	3786	0.9	134.25	22.0	A603 - 132S/6B F603 - 132S/6B	121	134
	7.9	3413	1.0	121.02	22.0			
	9.5	2826	1.2	100.21	22.0	A/F 603 - 112M/6 A/F 603 - 132S/6B	121	134
	10.2	2640	1.3	93.60	22.0			
	11.3	2379	1.5	84.37	22.0			
	11.9	2255	1.6	79.98	22.0			
	13.7	1970	1.8	69.87	22.0			
	17.1	1572	2.2	55.75	22.0	A603 - 132S/6B F603 - 132S/6B	121	134
	21.4	1287	3.9	44.67	30.0	A702 - 132S/6B F702 - 132S/6B	151	138
	11.1	2321	1.6	260.15	30.0	A703 - 100L/2A F703 - 100L/2A	128	138
	12.5	2064	1.8	231.34	30.0			
	13.9	1854	2.0	207.78	30.0			
	15.2	1691	2.2	189.54	30.0			
	16.7	1545	2.4	173.11	30.0			
	18.6	1387	2.7	155.48	30.0			
	19.9	1293	2.9	144.94	30.0			
	22.5	1145	3.3	128.35	30.0			
	24.3	1060	3.5	118.75	30.0			
	26.6	968	3.9	108.46	30.0			
	5.4	4969	1.0	260.15	30.0	A703 - 100L/4B F703 - 100L/4B	131	138
	6.1	4419	1.1	231.34	30.0			
	6.8	3969	1.3	207.78	30.0			
	7.4	3620	1.4	189.54	30.0			
	8.1	3306	1.5	173.11	30.0			
	9.1	2970	1.7	155.48	30.0			
	9.7	2768	1.8	144.94	30.0			
	11.0	2451	2.0	128.35	30.0			
	11.9	2268	2.2	118.75	30.0			
	13.0	2072	2.4	108.46	30.0			
	14.0	1917	2.6	100.38	30.0			
	15.7	1718	2.9	89.95	30.0			
	16.9	1592	3.1	83.35	30.0			
	19.1	1408	3.6	73.70	30.0			
	20.9	1286	3.9	67.31	30.0			
	5.0	5345	0.9	189.54	30.0	A703 - 112M/6 F703 - 112M/6	137	138
	5.5	4882	1.0	173.11	30.0			



P₁ [kW]	n₂ [Min ⁻¹]	M₂ [Nm]	f_B	i_{ges}	F_R [kN]	Typ / Type / Tipo / Type / Tipo	kg 	mm 			
3.00	6.1	4385	1.1	155.48	30.0	A/F 703 - 112M/6 A/F 703 - 132S/6B	151	138			
	6.6	4087	1.2	144.94	30.0						
	7.4	3620	1.4	128.35	30.0						
	8.0	3349	1.5	118.75	30.0						
	8.8	3058	1.6	108.46	30.0						
	9.5	2831	1.8	100.38	30.0						
	10.6	2537	2.0	89.95	30.0						
	11.5	2350	2.1	83.35	30.0						
	13.0	2078	2.4	73.70	30.0						
	14.2	1898	2.6	67.31	30.0						
	17.1	1572	3.2	55.75	30.0				A703 - 132S/6B F703 - 132S/6B	151	138
	20.9	1288	3.9	45.67	30.0						
	4.6	5802	1.4	205.73	55.0				A903 - 132S/6B F903 - 132S/6B	218	140
	5.1	5235	1.5	185.64	55.0						
	6.2	4345	1.8	154.07	55.0						
	6.9	3931	2.0	139.41	55.0						
	7.4	3620	2.2	128.36	55.0						
	8.2	3266	2.4	115.83	55.0						
	9.1	2944	2.7	104.41	55.0						
9.9	2711	3.0	96.13	55.0							
11.0	2437	3.3	86.43	55.0							
12.1	2231	3.6	79.13	55.0							
13.4	2013	4.0	71.40	55.0							
4.00	454.1	77	1.0	6.36	2.7	A252 - 100L/2C F252 - 100L/2C	36	114			
	602.3	58	1.2	4.80	2.6						
	209.3	168	1.1	13.81	4.2	A302 - 100L/2C F302 - 100L/2C	38	118			
	240.8	146	1.3	12.00	4.1						
	275.2	128	1.4	10.50	4.1						
	317.2	111	1.4	9.11	4.0						
	393.7	89	1.3	7.34	3.8						
	517.9	68	1.8	5.58	3.6	A/F 302 - 100L/2C A/F 302 - 112M/2A	45	118			
	256.3	143	1.1	5.58	4.1	A302 - 112M/4B F302 - 112M/4B	47	118			
	489.1	73	1.0	5.91	2.0	A351 - 100L/2C F351 - 100L/2C	33	120			
	541.9	66	1.1	5.33	1.9						
	596.3	60	1.2	4.85	1.9						
	710.7	51	1.3	4.07	1.8						
	770.7	47	1.4	3.75	1.8	A/F 351 - 100L/2C A/F 351 - 112M/2A	40	120			
	896.9	40	1.5	3.22	1.7						
	1103.1	33	1.6	2.62	1.6						
	1331.8	27	1.7	2.17	1.6						
	1993.1	18	2.5	1.45	1.4						
	2223.1	16	1.9	1.30	1.4						
	381.3	97	0.9	3.75	2.0				A351 - 112M/4B F351 - 112M/4B	42	120
	443.8	83	1.0	3.22	2.0						
	545.8	68	1.0	2.62	1.9						
	659.0	56	1.1	2.17	1.8						
	986.2	38	1.6	1.45	1.7						
	1100.0	34	1.2	1.30	1.6						
	100.0	351	1.0	28.89	6.2	A352 - 100L/2C F352 - 100L/2C	43	122			
	108.7	323	1.1	26.59	6.3						
	115.0	306	1.2	25.13	6.4						
	131.2	268	1.3	22.03	6.4						
142.3	247	1.4	20.31	6.5							
157.9	223	1.6	18.30	6.1							
171.2	205	1.6	16.88	6.0	A/F 352 - 100L/2C A/F 352 - 112M/2A	50	122				
199.0	177	1.8	14.52	5.9							
246.2	143	2.0	11.74	5.6							
296.4	119	2.3	9.75	5.4							
331.0	106	2.4	8.73	5.3							
409.3	86	2.5	7.06	5.0							
493.2	71	2.7	5.86	4.8							



P_1 [kW]	n_2 [Min ⁻¹]	M_2 [Nm]	f_B	i_{ges}	F_R [kN]	Typ / Type / Tipo / Type / Tipo	Kg	mm
4.00	78.1	469	1.0	18.30	6.5	A352 - 112M/4B F352 - 112M/4B	52	122
	84.7	433	1.0	16.88	6.4			
	98.5	372	1.2	14.52	6.4			
	121.8	301	1.3	11.74	6.3			
	146.7	250	1.5	9.75	6.1			
	163.8	224	1.5	8.73	6.0			
	202.5	181	1.6	7.06	5.8			
	244.0	150	1.7	5.86	5.6			
	350.3	103	1.2	8.25	3.5	A401 - 100L/2C F401 - 100L/2C	33	124
	400.2	90	1.4	7.22	3.4			
	504.4	71	1.8	5.73	3.2	A/F 401 - 100L/2C A/F 401 - 112M/2A	39	124
	559.0	64	2.0	5.17	3.1			
	616.2	58	2.1	4.69	3.0			
	735.4	49	2.3	3.93	2.8			
	798.3	45	2.5	3.62	2.8			
	929.3	39	2.5	3.11	2.7			
	1146.8	31	2.9	2.52	2.5			
	1389.4	26	3.5	2.08	2.4			
	2206.1	16	3.7	1.31	2.0			
	249.6	148	1.1	5.73	3.7	A401 - 112M/4B F401 - 112M/4B	42	124
	276.6	134	1.3	5.17	3.6			
	304.9	122	1.3	4.69	3.6			
	363.9	102	1.5	3.93	3.4			
	395.0	94	1.6	3.62	3.3			
	459.8	81	1.6	3.11	3.2			
	567.5	65	1.8	2.52	3.0			
	687.5	54	2.2	2.08	2.9			
	1091.6	34	2.4	1.31	2.5			
	63.7	552	1.2	45.38	12.0	A402 - 100L/2C F402 - 100L/2C	54	126
	72.8	483	1.3	39.72	12.0			
	79.3	443	1.4	36.44	12.0			
	91.7	383	1.7	31.50	12.0	A/F 402 - 100L/2C A/F 402 - 112M/2A	60	126
	100.0	351	1.7	28.89	12.0			
	114.2	308	2.1	25.30	12.0			
	126.1	279	2.3	22.91	12.0			
	144.9	242	2.6	19.94	11.7			
	166.4	211	2.9	17.37	11.3			
	180.5	195	3.1	16.01	11.1			
	199.3	176	3.0	14.50	10.8			
	232.3	151	3.5	12.44	10.4			
	252.2	139	3.5	11.46	10.2			
	314.1	112	4.0	9.20	9.6			
	45.4	808	1.1	31.50	12.0	A402 - 112M/4B F402 - 112M/4B	63	126
	49.5	741	1.1	28.89	12.0			
	56.5	649	1.3	25.30	12.0			
	62.4	588	1.4	22.91	12.0			
	71.7	511	1.7	19.94	12.0			
	82.3	445	1.9	17.37	12.0			
89.3	411	1.9	16.01	12.0				
98.6	372	1.9	14.50	12.0				
115.0	319	2.2	12.44	12.0				
124.8	294	2.2	11.46	12.0				
155.4	236	2.5	9.20	11.5				
171.6	214	2.8	8.33	11.2				
198.1	185	3.0	7.22	10.8				
246.7	149	3.7	5.80	10.2				
272.4	135	3.7	5.25	9.9				
41.9	875	1.0	22.91	12.0	A402 - 132M/6A F402 - 132M/6A			
48.2	762	1.1	19.94	12.0				
55.3	664	1.3	17.37	12.0				
60.0	612	1.3	16.01	12.0				
66.2	554	1.3	14.50	12.0				
77.1	475	1.5	12.44	12.0				
83.8	438	1.5	11.46	12.0				
104.3	351	1.7	9.20	12.0				
115.2	318	1.9	8.33	12.0				
133.0	276	2.0	7.22	12.0				
165.6	221	2.5	5.80	11.4				
182.9	201	2.5	5.25	11.1				



P₁ [kW]	n₂ [Min ⁻¹]	M₂ [Nm]	f_B	i_{ges}	F_R [kN]	Typ / Type / Tipo / Type / Tipo	kg ~	mm	
4.00	58.2	591	1.1	49.64	3.1	A403 - 100L/2C F403 - 100L/2C	54	126	
	337.6 380.3 468.6 514.7	106 94 77 70	2.5 2.8 3.3 3.5	8.56 7.60 6.17 5.62	4.0 3.9 3.7 3.6	A/F 501 - 100L/2C A/F 501 - 112M/2A	51	128	
	167.1 188.2 231.9 254.7 302.1 352.3 378.5 433.3	222 197 160 146 123 105 98 86	1.6 1.8 2.1 2.3 2.6 3.0 3.2 3.6	8.56 7.60 6.17 5.62 4.73 4.06 3.78 3.30	4.0 4.0 4.0 4.0 4.0 4.0 3.9 3.8	A501 - 112M/4B F501 - 112M/4B	53	128	
	112.2 126.3 155.7 171.0 202.8 236.5 254.1 290.9 371.6 488.4 658.8 724.9	330 293 238 217 183 157 146 127 100 76 56 51	1.1 1.2 1.4 1.5 1.8 2.0 2.1 2.4 2.8 3.0 3.9 3.9	8.56 7.60 6.17 5.62 4.73 4.06 3.78 3.30 2.58 1.97 1.46 1.32	4.0 4.0 4.0 4.0 4.0 4.0 4.0 4.0 3.9 3.7 4.0 4.0	A501 - 132M/6A F501 - 132M/6A	73	128	
	59.3 66.7 73.7 83.0 91.5 102.3 107.1	593 527 477 424 384 344 328	2.0 2.3 2.5 2.8 3.1 3.5 3.7	48.77 43.32 39.21 34.83 31.57 28.26 26.98	18.0 18.0 17.7 17.1 16.7 16.2 16.0	A/F 502 - 100L/2C A/F 502 - 112M/2A	78	130	
	29.3 33.0 36.5 41.1 45.3 50.6 53.0 61.8 65.9 72.7 76.0 84.8 94.5 104.3	1251 1111 1006 893 810 725 692 593 556 504 482 432 388 352	1.3 1.4 1.6 1.8 2.0 2.2 2.3 2.7 2.9 3.2 3.1 3.5 3.9 4.0	48.77 43.32 39.21 34.83 31.57 28.26 26.98 23.14 21.69 19.66 18.81 16.86 15.13 13.71	18.0 18.0 18.0 18.0 18.0 18.0 18.0 18.0 18.0 17.6 17.4 16.9 16.5 16.0	A502 - 112M/4B F502 - 112M/4B	80	130	
	22.2 24.5 27.6 30.4 34.0 35.6 41.5 44.3 48.8 51.0 56.9 63.5 70.0 85.7 106.6 117.6 127.2 158.2 174.5	1655 1498 1331 1206 1080 1031 884 829 751 719 644 578 524 428 344 312 288 232 210	1.0 1.1 1.2 1.3 1.5 1.6 1.8 1.9 2.1 2.1 2.3 2.6 2.7 2.6 2.6 2.6 2.8 3.0 3.3	43.32 39.21 34.83 31.57 28.26 26.98 23.14 21.69 19.66 18.81 16.86 15.13 13.71 11.20 9.01 8.16 7.55 6.07 5.50	18.0 18.0 18.0 18.0 18.0 18.0 18.0 18.0 18.0 18.0 18.0 18.0 17.9 17.0 16.1 15.7 15.4 14.5 14.1	A502 - 132M/6A F502 - 132M/6A	100	130	

P_1 [kW]	n_2 [Min ⁻¹]	M_2 [Nm]	f_B	i_{ges}	F_R [kN]	Typ / Type / Tipo / Type / Tipo	Kg	mm
4.00	29.5 33.9 36.7	1163 1015 936	1.2 1.3 1.4	97.80 85.33 78.64	18.0 18.0 18.0	A503 - 100L/2C F503 - 100L/2C	71	130
	40.6 51.4	848 669	1.6 1.8	71.27 56.21	18.0 18.0	A/F 503 - 100L/2C A/F 503 - 112M/2A	78	130
	20.1 25.4	1790 1411	1.0 1.1	71.27 56.21	18.0 18.0	A503 - 112M/4B F503 - 112M/4B	80	130
	172.3 191.8 232.4	215 193 159	3.0 3.4 4.0	8.30 7.45 6.15	5.0 5.0 5.0	A601 - 112M/4B F601 - 112M/4B	65	132
	115.7 128.8 156.0 184.6 199.5 224.4	320 288 238 201 186 165	2.0 2.3 2.7 3.1 3.3 3.7	8.30 7.45 6.15 5.20 4.81 4.28	5.0 5.0 5.0 5.0 5.0 5.0	A601 - 132M/6A F601 - 132M/6A	85	132
	56.8	619	4.0	50.91	22.0	A/F 602 - 100L/2C A/F 602 - 112M/2A	106	134
	28.1 31.6 35.0 37.6 42.3 47.1	1306 1161 1047 975 867 778	2.5 2.8 3.2 2.9 3.7 4.1	50.91 45.27 40.81 38.00 33.79 30.35	22.0 22.0 22.0 22.0 22.0 22.0	A602 - 112M/4B F602 - 112M/4B	108	134
	18.9 21.2 23.5 25.3 28.4 31.6 33.8 37.5 40.6 45.3	1965 1747 1575 1467 1304 1171 1095 987 913 817	1.7 1.9 2.1 1.9 2.5 2.7 3.0 3.3 3.6 3.9	50.91 45.27 40.81 38.00 33.79 30.35 28.36 25.57 23.66 21.17	22.0 22.0 22.0 22.0 22.0 22.0 22.0 22.0 22.0 22.0	A602 - 132M/6A F602 - 132M/6A	128	134
	14.9 16.0 18.0	2312 2155 1914	1.1 1.2 1.4	194.31 181.13 160.90	22.0 22.0 22.0	A603 - 100L/2C F603 - 100L/2C	99	134
	20.1 21.5 23.9 28.8 30.9 34.3 36.1 41.4	1708 1597 1440 1192 1113 1004 951 831	1.5 1.6 1.8 2.2 2.4 2.6 2.8 3.2	143.57 134.25 121.02 100.21 93.60 84.37 79.98 69.87	22.0 22.0 22.0 22.0 22.0 22.0 22.0 22.0	A/F 603 - 100L/2C A/F 603 - 112M/2A	106	134
	10.0 10.7 11.8 14.3 15.3 16.9 17.9 20.5	3605 3371 3039 2516 2350 2119 2008 1754	1.0 1.0 1.2 1.4 1.5 1.7 1.7 2.0	143.57 134.25 121.02 100.21 93.60 84.37 79.98 69.87	22.0 22.0 22.0 22.0 22.0 22.0 22.0 22.0	A603 - 112M/4B F603 - 112M/4B	108	134
	9.6 10.3 11.4 12.0 13.7 17.2	3748 3501 3156 2992 2613 2085	0.9 1.0 1.1 1.2 1.3 1.7	100.21 93.60 84.37 79.98 69.87 55.75	22.0 22.0 22.0 22.0 22.0 22.0	A603 - 132M/6A F603 - 132M/6A	128	134
	123.1 151.6	301 244	3.3 3.7	7.80 6.33	6.0 6.0	A701 - 132M/6A F701 - 132M/6A	88	136
	21.5 26.2 28.7	1706 1398 1277	2.9 3.6 3.9	44.67 36.60 33.43	30.0 30.0 30.0	A702 - 132M/6A F702 - 132M/6A	158	138



P_1 [kW]	n_2 [Min ⁻¹]	M_2 [Nm]	f_B	i_{ges}	F_R [kN]	Typ / Type / Tipo / Type / Tipo	 Kg	 mm
4.00	11.1	3095	1.2	260.15	30.0	A703 - 100L/2C F703 - 100L/2C	129	138
	12.5	2752	1.4	231.34	30.0			
	13.9	2472	1.5	207.78	30.0	A/F 703 - 100L/2C A/F 703 - 112M/2A	135	138
	15.2	2255	1.7	189.54	30.0			
	16.7	2059	1.8	173.11	30.0			
	18.6	1850	2.0	155.48	30.0			
	19.9	1724	2.2	144.94	30.0			
	22.5	1527	2.5	128.35	30.0			
	24.3	1413	2.7	118.75	30.0			
	26.6	1290	2.9	108.46	30.0			
	28.8	1194	3.1	100.38	30.0			
	32.1	1070	3.5	89.95	30.0			
	34.7	992	3.8	83.35	30.0			
	6.9	5217	1.0	207.78	30.0	A703 - 112M/4B F703 - 112M/4B	137	138
	7.5	4759	1.1	189.54	30.0			
	8.3	4347	1.2	173.11	30.0			
	9.2	3904	1.3	155.48	30.0			
	9.9	3640	1.4	144.94	30.0			
	11.1	3223	1.6	128.35	30.0			
	12.0	2982	1.7	118.75	30.0			
	13.2	2723	1.8	108.46	30.0			
	14.2	2521	2.0	100.38	30.0			
	15.9	2259	2.2	89.95	30.0			
	17.2	2093	2.4	83.35	30.0			
	19.4	1851	2.7	73.70	30.0			
	21.2	1690	3.0	67.31	30.0			
	7.5	4888	1.0	128.35	30.0	A703 - 132M/6A F703 - 132M/6A	158	138
	8.1	4522	1.1	118.75	30.0			
	8.9	4130	1.2	108.46	30.0			
	9.6	3822	1.3	100.38	30.0			
	10.7	3425	1.5	89.95	30.0			
	11.5	3174	1.6	83.35	30.0			
	13.0	2806	1.8	73.70	30.0			
	14.3	2563	2.0	67.31	30.0			
	17.2	2123	2.4	55.75	30.0			
	21.0	1739	2.9	45.67	30.0			
	4.7	7834	1.0	205.73	55.0	A903 - 132M/6A F903 - 132M/6A	235	140
	5.2	7069	1.1	185.64	55.0			
	6.2	5867	1.4	154.07	55.0			
	6.9	5309	1.5	139.41	55.0			
	7.5	4888	1.6	128.36	55.0			
	8.3	4411	1.8	115.83	55.0			
	9.2	3976	2.0	104.41	55.0			
	10.0	3661	2.2	96.13	55.0			
	11.1	3291	2.4	86.43	55.0			
	12.1	3013	2.7	79.13	55.0			
	13.4	2719	2.9	71.40	55.0			
15.2	2400	3.3	63.02	55.0				
16.2	2257	3.5	59.26	55.0				
17.9	2043	3.9	53.66	55.0				
4.80	259.0	170	0.9	5.58	3.8	A302 - 112M/4 F302 - 112M/4	47	118
	995.4	44	1.4	1.45	1.6	A351 - 112M/4 F351 - 112M/4	42	120
	1109.0	40	1.0	1.30	1.6			
	99.5	442	1.0	14.52	5.9	A352 - 112M/4 F352 - 112M/4	52	122
	123.1	358	1.1	11.74	5.9			
	148.2	297	1.2	9.75	5.8			
	165.5	266	1.3	8.73	5.7			
	204.7	215	1.3	7.06	5.5			
	246.6	178	1.5	5.86	5.4			

P_1 [kW]	n_2 [Min ⁻¹]	M_2 [Nm]	f_B	i_{ges}	F_R [kN]	Typ / Type / Tipo / Type / Tipo	 Kg	 mm
4.80	252.2	176	1.0	5.73	3.6	A401 - 112M/4 F401 - 112M/4	42	124
	279.5	159	1.1	5.17	3.5			
	308.1	144	1.1	4.69	3.5			
	367.7	121	1.2	3.93	3.3			
	399.2	111	1.3	3.62	3.3			
	464.6	96	1.4	3.11	3.2			
	573.4	78	1.5	2.52	3.0			
	694.7	64	1.9	2.08	2.8			
	1103.1	40	2.0	1.31	2.5			
		57.1	770	1.1	25.30			
63.1		698	1.2	22.91	12.0			
72.5		607	1.4	19.94	12.0			
83.2		529	1.6	17.37	12.0			
90.3		488	1.6	16.01	12.0			
99.7		442	1.6	14.50	12.0			
116.2		379	1.8	12.44	11.9			
126.1		349	1.9	11.46	11.7			
157.1		280	2.1	9.20	11.2			
173.5		254	2.4	8.33	10.9			
	200.1	220	2.5	7.22	10.6	A501 - 112M/4 F501 - 112M/4	53	128
	149.1	177	3.1	5.80	10.0			
	275.2	160	3.1	5.25	9.8			
	168.8	263	1.3	8.56	4.0			
	190.1	234	1.5	7.60	4.0			
	234.2	190	1.8	6.17	4.0			
	257.1	173	1.9	5.62	4.0			
	305.3	146	2.2	4.73	4.0			
	356.0	125	2.6	4.06	4.0	A502 - 112M/4 F502 - 112M/4	80	130
	382.5	116	2.7	3.78	3.9			
	437.9	102	3.1	3.30	3.7			
	559.4	79	3.5	2.58	3.5			
	29.6	1485	1.1	48.77	18.0			
	33.4	1292	1.2	43.32	18.0			
	36.9	1169	1.4	39.21	18.0			
	41.5	1039	1.5	34.83	18.0			
	45.8	941	1.7	31.57	18.0			
	51.1	843	1.9	28.26	18.0			
53.6	805	2.0	26.98	18.0				
62.5	690	2.3	23.14	17.7				
66.6	647	2.5	21.69	17.5				
73.5	586	2.7	19.66	17.1				
76.8	561	2.7	18.81	16.9				
85.7	503	3.0	16.86	16.5				
95.5	451	3.3	15.13	16.1				
105.4	409	3.4	13.71	15.7				
25.7	1676	1.0	56.21	18.0	A503 - 112M/4 F503 - 112M/4	80	130	
	174.1	255	2.5	8.30	5.0	A601 - 112M/4 F601 - 112M/4	108	132
	193.8	229	2.8	7.45	5.0			
	234.8	189	3.4	6.15	5.0			
	277.9	160	3.9	5.20	5.0			
	28.4	1550	2.1	50.91	22.0	A602 - 112M/4 F602 - 112M/4	108	134
	31.9	1379	2.4	45.27	22.0			
	35.4	1243	2.7	40.81	22.0			
	38.0	1157	2.4	38.00	22.0			
	42.8	1029	3.1	33.79	22.0			
	47.6	924	3.5	30.35	22.0			
50.9	864	3.8	28.36	22.0				
	11.9	3609	1.0	121.02	22.0	A603 - 112M/4 F603 - 112M/4	108	134
	14.4	2988	1.2	100.21	22.0			
	15.4	2791	1.3	93.60	22.0			
	17.1	2516	1.4	84.37	22.0			
	18.1	2385	1.5	79.98	22.0			
	20.7	2084	1.7	69.87	22.0			



P_1 [kW]	n_2 [Min ⁻¹]	M_2 [Nm]	f_B	i_{ges}	F_R [kN]	Typ / Type / Tipo / Type / Tipo	 Kg	 mm		
4.80	8.3	5162	1.0	173.11	30.0	A703 - 112M/4 F703 - 112M/4	137	138		
	9.3	4636	1.1	155.48	30.0					
	10.0	4322	1.2	144.94	30.0					
	11.3	3827	1.3	128.35	30.0					
	12.2	3541	1.4	118.75	30.0					
	13.3	3234	1.5	108.46	30.0					
	14.4	2993	1.7	100.38	30.0					
	16.1	2682	1.9	89.95	30.0					
	17.3	2485	2.0	83.35	30.0					
	19.6	2198	2.3	73.70	30.0					
21.5	2007	2.5	67.31	30.0						
5.50	519.6	93	1.3	5.58	3.4	A302 - 112M/2C F302 - 112M/2C	45	118		
	773.3	64	1.1	3.75	1.7	A351 - 112M/2C F351 - 112M/2C	43	120		
	900.0	55	1.1	3.22	1.6					
	1107.3	45	1.2	2.62	1.6					
	1338.5	37	1.2	2.17	1.5					
	1997.8	25	1.8	1.45	1.4					
	2225.6	22	1.4	1.30	1.3					
	158.5	305	1.1	18.30	5.6	A352 - 112M/2C F352 - 112M/2C	50	122		
	171.9	281	1.2	16.88	5.5					
	199.8	242	1.3	14.52	5.4					
	247.1	196	1.5	11.74	5.3					
	297.4	162	1.7	9.75	5.1					
	332.2	145	1.8	8.73	5.0					
	410.9	118	1.8	7.06	4.8					
	494.6	98	2.0	5.86	4.6					
	506.3	98	1.3	5.73	3.0	A401 - 112M/2C F401 - 112M/2C	40	124		
	561.3	88	1.4	5.17	3.0					
	618.0	80	1.5	4.69	2.9					
	737.3	67	1.7	3.93	2.8					
	800.0	62	1.8	3.63	2.7					
	932.1	53	1.8	3.11	2.6					
	1149.1	43	2.1	2.52	2.4					
	1392.0	35	2.5	2.08	2.3					
	2209.5	22	2.7	1.31	2.0					
	92.1	525	1.2	31.50	12.0				A402 - 112M/2C F402 - 112M/2C	61
	100.4	481	1.2	28.89	12.0					
	114.6	422	1.5	25.30	11.7	A/F 402 - 112M/2C A/F 402 - 132S/2A	74	126		
126.6	382	1.7	22.91	11.5						
145.4	332	1.9	19.94	11.2						
167.0	289	2.2	17.37	10.9						
181.1	267	2.2	16.01	10.7						
200.0	242	2.2	14.50	10.4						
233.1	207	2.5	12.44	10.0						
253.1	191	2.6	11.46	9.9						
315.2	153	2.9	9.20	9.3						
348.1	139	3.2	8.33	9.1						
401.7	120	3.4	7.22	8.7						
552.4	87	4.3	5.25	8.2						
60.0	841	1.0	16.01	12.0	A402 - 132M/6B F402 - 132M/6B				88	126
77.2	653	1.1	12.44	12.0						
83.8	602	1.1	11.46	12.0						
104.3	483	1.2	9.20	11.8						
115.2	438	1.4	8.33	11.6						
133.0	379	1.5	7.22	11.3						
165.5	305	1.8	5.80	10.9						
182.9	276	1.8	5.25	10.6						

P_1 [kW]	n_2 [Min ⁻¹]	M_2 [Nm]	f_B	i_{ges}	F_R [kN]	Typ / Type / Tipo / Type / Tipo	 Kg ~	 mm
5.50	57.1	883	1.0	25.30	12.0	A402 - 132S/4C F402 - 132S/4C	79	126
	63.1	799	1.1	22.91	12.0			
	72.5	696	1.2	19.94	12.0			
	83.2	606	1.4	17.37	12.0			
	90.3	559	1.4	16.01	12.0			
	99.7	506	1.4	14.50	11.9			
	116.2	434	1.6	12.44	11.6			
	126.1	400	1.6	11.46	11.4			
	157.1	321	1.9	9.20	10.9			
	173.5	291	2.1	8.33	10.7			
200.1	252	2.2	7.22	10.4				
249.1	202	2.7	5.80	9.8				
275.2	183	2.7	5.25	9.6				
	338.8	146	1.8	8.56	4.0	A/F 501 - 112M/2C A/F 501 - 132S/2A	64	128
	381.6	129	2.0	7.60	3.8			
	470.0	105	2.4	6.17	3.7			
	516.0	96	2.6	5.62	3.6			
	613.1	81	3.0	4.73	3.3			
	714.3	69	3.5	4.06	3.2			
	767.2	64	3.6	3.78	3.1			
	155.7	327	1.0	6.17	4.0	A501 - 132M/6B F501 - 132M/6B	78	128
	171.0	298	1.1	5.62	4.0			
	202.8	251	1.3	4.73	4.0			
	236.5	215	1.5	4.06	4.0			
	254.1	200	1.5	3.78	4.0			
	290.9	175	1.8	3.30	4.0			
	371.6	137	2.0	2.58	3.9			
	488.4	104	2.2	1.97	3.6			
	658.8	77	2.8	1.46	3.3			
724.9	70	2.8	1.32	3.2				
	168.8	302	1.2	8.56	4.0	A501 - 132S/4C F501 - 132S/4C	69	128
	190.1	268	1.3	7.60	4.0			
	234.2	218	1.6	6.17	4.0			
	257.1	198	1.7	5.62	4.0			
	305.5	167	1.9	4.73	4.0			
	355.9	143	2.2	4.06	3.9			
	382.3	133	2.3	3.78	3.8			
	437.9	116	2.7	3.30	3.7			
	560.1	91	3.1	2.58	3.4			
	733.5	69	3.3	1.97	3.2			
	59.5	813	1.5	48.77	17.5	A/F 502 - 112M/2C A/F 502 - 132S/2A	91	130
	66.9	722	1.7	43.32	17.2			
	74.0	653	1.8	39.21	16.8			
	83.3	580	2.1	34.83	16.4			
	91.9	526	2.3	31.57	16.0			
	102.6	471	2.5	28.26	15.6			
	107.5	450	2.7	26.98	15.5			
	125.3	386	3.1	23.14	14.9			
	133.7	361	3.3	21.69	14.7			
	147.5	328	3.7	19.66	14.3			
	154.2	313	3.6	18.81	14.1			
	172.0	281	4.0	16.86	13.7			
		30.4	1658	1.0	31.57			
34.0		1484	1.1	28.26	18.0			
35.6		1417	1.1	26.98	18.0			
41.5		1215	1.3	23.14	18.0			
44.3		1139	1.4	21.69	18.0			
48.8		1033	1.5	19.66	18.0			
51.0		988	1.5	18.81	17.9			
56.9		886	1.7	16.86	17.6			
63.5		794	1.9	15.13	17.3			
70.0		720	1.9	13.71	16.9			
85.7		588	1.9	11.20	16.3			
106.6		473	1.9	9.01	15.5			
117.6		429	1.9	8.16	15.1			
127.2		396	2.0	7.55	14.8			
158.2		319	2.2	6.07	14.1			
174.5		289	2.4	5.50	13.7			



P₁ [kW]	n₂ [Min ⁻¹]	M₂ [Nm]	f_B	i_{ges}	F_R [kN]	Typ / Type / Tipo / Type / Tipo	Kg ~	mm
5.50	29.6	1702	0.9	48.77	18.0	A502 - 132S/4C F502 - 132S/4C	96	130
	33.4	1512	1.1	43.32	18.0			
	36.9	1368	1.2	39.21	18.0			
	41.5	1215	1.3	34.83	18.0			
	45.8	1102	1.5	31.57	18.0			
	51.1	986	1.6	28.26	17.8			
	53.6	941	1.7	26.98	17.7			
	62.4	807	2.0	23.14	17.2			
	66.6	757	2.1	21.69	17.0			
	73.5	686	2.3	19.66	16.7			
	76.8	656	2.3	18.81	16.6			
	85.7	588	2.5	16.86	16.2			
	95.5	528	2.8	15.13	15.8			
	105.4	478	2.9	13.71	15.4			
	129.0	391	2.8	11.20	14.7			
	160.4	314	2.9	9.01	13.9			
	177.0	285	2.8	8.16	13.6			
	191.4	263	3.0	7.55	13.3			
	238.1	212	3.3	6.07	12.5			
	262.7	192	3.6	5.50	12.2			
	40.7	1162	1.2	71.27	18.0	A503 - 112M/2C F503 - 112M/2C	78	130
	51.6	916	1.3	56.21	18.0			
	349.4	141	3.4	8.30	5.0	A/F 601 - 112M/2C A/F 601 - 132S/2A	76	132
	389.0	127	3.8	7.45	4.9			
	115.7	440	1.5	8.30	5.0	A601 - 132M/6B F601 - 132M/6B	90	132
	128.8	396	1.6	7.45	5.0			
	156.0	327	2.0	6.15	5.0			
	184.6	276	2.2	5.20	5.0			
	199.5	255	2.4	4.81	5.0			
	224.4	227	2.7	4.28	5.0			
	263.0	194	3.1	3.65	5.0			
	297.5	171	3.5	3.23	5.0			
	174.1	293	2.2	8.30	5.0	A601 - 132S/4C F601 - 132S/4C	92	132
	193.8	263	2.5	7.45	5.0			
	234.8	217	2.9	6.15	5.0			
	277.9	183	3.4	5.20	5.0			
	300.3	170	3.7	4.81	5.0			
337.8	151	4.0	4.28	5.0				
57.0	848	2.9	50.91	22.0	A/F 602 - 112M/2C A/F 602 - 132S/2A	119	134	
64.1	754	3.3	45.27	22.0				
71.1	680	3.6	40.81	22.0				
76.3	633	3.3	38.00	22.0				
18.9	2674	1.2	50.91	22.0	A602 - 132M/6B F602 - 132M/6B	133	134	
21.2	2378	1.4	45.27	22.0				
23.5	2143	1.5	40.81	22.0				
25.3	1996	1.4	38.00	22.0				
28.4	1775	1.8	33.79	22.0				
31.6	1594	2.0	30.35	22.0				
33.8	1490	2.2	28.36	22.0				
37.5	1343	2.5	25.57	22.0				
40.6	1243	2.7	23.66	22.0				
45.3	1112	2.9	21.17	22.0				
49.0	1029	3.1	19.59	22.0				
54.5	925	3.5	17.60	22.0				
60.5	833	3.8	15.87	22.0				
28.4	1777	1.9	50.91	22.0				A602 - 132S/4C F602 - 132S/4C
31.9	1580	2.1	45.27	22.0				
35.4	1424	2.3	40.81	22.0				
38.0	1326	2.1	38.00	22.0				
42.8	1179	2.7	33.79	22.0				
47.6	1059	3.0	30.35	22.0				
50.9	990	3.3	28.36	22.0				
56.5	892	3.7	25.57	22.0				
61.1	826	4.0	23.66	22.0				
20.2	2340	1.1	143.57	22.0	A603 - 112M/2C F603 - 112M/2C	106	134	
21.6	2188	1.2	134.25	22.0				
24.0	1973	1.3	121.02	22.0				

P_1 [kW]	n_2 [Min ⁻¹]	M_2 [Nm]	f_B	i_{ges}	F_R [kN]	Typ / Type / Tipo / Type / Tipo	 Kg	 mm		
5.50	28.9	1634	1.6	100.21	22.0	A/F 603 - 112M/2C A/F 603 - 132S/2A	119	134		
	31.0	1526	1.7	93.60	22.0					
	34.4	1375	1.9	84.37	22.0					
	36.3	1304	2.0	79.98	22.0					
	41.5	1139	2.3	69.87	22.0					
	13.7	3593	1.0	69.87	22.0	A603 - 132M/6B F603 - 132M/6B	133	134		
	17.2	2867	1.2	55.75	22.0					
	14.4	3424	1.0	100.21	22.0	A603 - 132S/4C F603 - 132S/4C	135	134		
	15.4	3198	1.1	93.60	22.0					
	17.1	2883	1.2	84.37	22.0					
	18.1	2733	1.3	79.98	22.0					
	20.7	2387	1.5	69.87	22.0					
	25.9	1905	1.8	55.75	22.0					
	52.0	909	2.9	55.75	22.0	A603 - 132S/2A F603 - 132S/2A	119	134		
	123.1	414	2.4	7.80	6.0	A701 - 132M/6B F701 - 132M/6B	93	136		
	151.6	336	2.7	6.33	6.0					
	181.6	281	3.1	5.29	6.0					
	197.3	258	3.4	4.87	6.0					
	229.9	222	3.8	4.18	6.0					
	185.3	275	3.6	7.80	6.0	A701 - 132S/4C F701 - 132S/4C	84	136		
	228.2	223	4.0	6.33	6.0					
	21.5	2346	2.1	44.67	30.0	A702 - 132M/6B F702 - 132M/6B	163	138		
	26.2	1922	2.6	36.60	30.0					
	28.7	1756	2.8	33.43	30.0					
	31.7	1590	3.1	30.27	30.0					
	34.4	1464	3.4	27.87	30.0					
	38.7	1303	3.8	24.80	30.0					
	32.3	1559	3.2	44.67	30.0	A702 - 132S/4C F702 - 132S/4C	154	138		
	39.5	1277	3.9	36.60	30.0					
	14.0	3387	1.1	207.78	30.0	A703 - 112M/2C F703 - 112M/2C	135	138		
	15.3	3090	1.2	189.54	30.0					
	16.8	2822	1.3	173.11	30.0					
18.7	2534	1.5	155.48	30.0	A/F 703 - 112M/2C A/F 703 - 132S/2A	149	138			
20.0	2363	1.6	144.94	30.0						
22.6	2092	1.8	128.35	30.0						
24.4	1936	1.9	118.75	30.0						
26.7	1768	2.1	108.46	30.0						
28.9	1636	2.3	100.38	30.0						
32.2	1466	2.6	89.95	30.0						
34.8	1359	2.8	83.35	30.0						
39.3	1201	3.1	73.70	30.0						
43.1	1097	3.4	67.31	30.0						
9.6	5218	1.0	100.38	30.0				A703 - 132M/6B F703 - 132M/6B	163	138
10.7	4675	1.1	89.95	30.0						
11.5	4332	1.2	83.35	30.0						
13.0	3831	1.3	73.70	30.0						
14.3	3499	1.4	67.31	30.0						
17.2	2898	1.7	55.75	30.0						
21.0	2374	2.1	45.67	30.0						
9.3	5313	0.9	155.48	30.0	A703 - 132S/4C F703 - 132S/4C	154	138			
10.0	4952	1.0	144.94	30.0						
11.3	4386	1.1	128.35	30.0						
12.2	4058	1.2	118.75	30.0						
13.3	3706	1.3	108.46	30.0						
14.4	3430	1.5	100.38	30.0						
16.1	3073	1.6	89.95	30.0						
17.3	2848	1.8	83.35	30.0						
19.6	2518	2.0	73.70	30.0						
21.5	2300	2.2	67.31	30.0						
25.9	1905	2.6	55.75	30.0						
31.6	1561	3.2	45.67	30.0						
52.0	949	3.9	55.75	30.0				A703 - 132S/2A F703 - 132S/2A	149	138

P₁ [kW]	n₂ [Min ⁻¹]	M₂ [Nm]	f_B	i_{ges}	F_R [kN]	Typ / Type / Tipo / Type / Tipo	kg ~	mm			
5.50	6.2	7966	1.0	154.07	55.0	A903 - 132M/6B F903 - 132M/6B	238	140			
	6.9	7208	1.1	139.41	55.0						
	7.5	6637	1.2	128.36	55.0						
	8.3	5989	1.3	115.83	55.0						
	9.2	5398	1.5	104.41	55.0						
	10.0	4970	1.6	96.13	55.0						
	11.1	4469	1.8	86.43	55.0						
	12.1	4091	2.0	79.13	55.0						
	13.4	3692	2.2	71.40	55.0						
	15.2	3258	2.5	63.02	55.0						
	16.2	3064	2.6	59.26	55.0						
	17.9	2775	2.9	53.66	55.0						
	7.0	7029	1.1	205.73	55.0				A903 - 132S/4C F903 - 132S/4C	221	140
	7.8	6343	1.3	185.64	55.0						
	9.4	5264	1.5	154.07	55.0						
	10.4	4763	1.7	139.41	55.0						
	11.3	4386	1.8	128.36	55.0						
	12.5	3958	2.0	115.83	55.0						
	13.8	3568	2.2	104.41	55.0						
	15.0	3285	2.4	96.13	55.0						
	16.7	2953	2.7	86.43	55.0						
	18.3	2704	3.0	79.13	55.0						
	20.2	2440	3.3	71.40	55.0						
	22.9	2153	3.7	63.02	55.0						
	24.4	2025	4.0	59.26	55.0						
	14.1	3354	1.8	205.73	55.0	A903 - 132S/2A F903 - 132S/2A	216	140			
	15.6	3026	2.0	185.64	55.0						
	18.8	2511	2.4	154.07	55.0						
	20.8	2273	2.6	139.41	55.0						
	22.6	2092	2.9	128.36	55.0						
	25.0	1888	3.2	115.83	55.0						
	27.8	1702	3.5	104.41	55.0						
	30.2	1567	3.8	96.13	55.0						
7.50	83.5	824	1.0	17.37	10.8	A402 - 132M/4B F402 - 132M/4B	90	126			
	90.6	759	1.1	16.01	10.8						
	100.0	688	1.0	14.50	10.8						
	116.6	590	1.2	12.44	10.6						
	126.5	543	1.2	11.46	10.5						
	157.6	436	1.4	9.20	10.2						
	174.1	395	1.5	8.33	10.1						
	200.8	342	1.6	7.22	9.8						
	250.0	275	2.0	5.80	9.4						
	276.2	249	2.0	5.25	9.2						
	126.6	521	1.2	22.91	10.6				A402 - 132S/2C F402 - 132S/2C	81	126
	145.5	453	1.4	19.94	10.4						
	166.9	395	1.6	17.37	10.2						
	181.1	364	1.6	16.01	10.1						
	200.0	329	1.6	14.50	9.9						
	233.0	283	1.9	12.44	9.6						
	253.1	260	1.9	11.46	9.4						
	315.2	209	2.2	9.20	9.0						
	348.0	189	2.4	8.33	8.8						
	401.7	164	2.5	7.22	8.5						
	500.3	132	3.1	5.80	8.0						
	552.4	119	3.1	5.25	7.8						
	190.8	364	1.0	7.60	4.0	A501 - 132M/4B F501 - 132M/4B	80	128			
	235.0	296	1.2	6.17	4.0						
	258.0	269	1.2	5.62	4.0						
	306.6	227	1.4	4.73	4.0						
	357.1	195	1.6	4.06	3.8						
	383.6	181	1.7	3.78	3.7						
	439.4	158	2.0	3.30	3.6						
	562.0	124	2.3	2.58	3.4						
	736.0	94	2.4	1.97	3.1						
	993.2	70	3.1	1.46	2.8						
	1098.5	63	3.2	1.32	2.8						



P_1 [kW]	n_2 [Min ⁻¹]	M_2 [Nm]	f_B	i_{ges}	F_R [kN]	Typ / Type / Tipo / Type / Tipo	 Kg ~	 mm
7.50	338.8	199	1.3	8.56	3.9	A501 - 132S/2C F501 - 132S/2C	71	128
	381.6	176	1.5	7.60	3.7			
	470.0	143	1.8	6.17	3.5			
	516.0	130	1.9	5.62	3.4			
	613.1	110	2.2	4.73	3.3			
	714.3	94	2.5	4.06	3.1			
	767.2	88	2.6	3.78	3.1			
	878.8	77	3.0	3.30	3.0			
	1124.0	60	3.5	2.58	2.8			
	1472.1	46	3.8	1.97	2.7			
	41.6	1652	1.0	34.83	16.3	A502 - 132M/4B F502 - 132M/4B	107	130
	45.9	1497	1.1	31.57	16.3			
	51.3	1340	1.2	28.26	16.2			
	53.7	1279	1.3	26.98	16.1			
	62.7	1097	1.5	23.14	15.9			
	66.9	1029	1.6	21.69	15.8			
	73.8	932	1.7	19.66	15.5			
	77.1	892	1.7	18.81	15.4			
	86.0	800	1.9	16.86	15.2			
	95.8	717	2.1	15.13	14.9			
	105.8	650	2.2	13.71	14.6			
	129.5	531	2.1	11.20	14.0			
	160.9	427	2.1	9.01	13.4			
	177.7	387	2.1	8.16	13.1			
	192.1	358	2.2	7.55	12.8			
	238.9	288	2.4	6.07	12.1			
263.6	261	2.7	5.50	12.1				
	59.5	1108	1.1	48.77	16.2	A502 - 132S/2C F502 - 132S/2C	98	130
	66.9	984	1.2	43.32	15.9			
	74.0	891	1.3	39.21	15.7			
	83.3	791	1.5	34.83	15.4			
	91.9	717	1.7	31.57	15.1			
	102.6	642	1.9	28.26	14.8			
	107.5	613	2.0	26.98	14.7			
	125.3	526	2.3	23.14	14.2			
	133.7	493	2.4	21.69	14.0			
	147.5	447	2.7	19.66	13.7			
	154.2	427	2.6	18.81	13.6			
	172.0	383	2.9	16.86	13.2			
	191.7	344	3.3	15.13	12.9			
	211.6	311	3.4	13.71	12.6			
	258.8	255	3.2	11.20	11.9			
	321.9	205	3.3	9.01	11.3			
	355.2	186	3.2	8.16	11.0			
	384.2	172	3.5	7.55	10.7			
477.8	138	3.8	6.07	10.1				
	41.5	1657	1.0	23.14	16.2	A502 - 160M/6B F502 - 160M/6B	139	130
	44.3	1554	1.0	21.69	16.2			
	48.8	1408	1.1	19.66	16.2			
	51.0	1347	1.1	18.81	16.1			
	56.9	1208	1.2	16.86	16.0			
	63.5	1083	1.4	15.13	15.9			
	70.0	982	1.4	13.71	15.7			
	85.7	802	1.4	11.20	15.2			
	106.6	645	1.4	9.01	14.7			
	117.6	585	1.4	8.16	14.4			
	127.2	541	1.5	7.55	14.1			
	158.2	435	1.6	6.07	13.5			
	174.5	394	1.8	5.50	13.2			
		174.7	398	1.6	8.30			
194.6		357	1.8	7.45	5.0			
235.8		295	2.2	6.15	5.0			
278.8		249	2.5	5.20	5.0			
301.3		231	2.7	4.81	5.0			
339.0		205	3.0	4.28	5.0			
397.3		175	3.4	3.65	4.8			
449.3		155	3.9	3.23	4.7			

P₁ [kW]	n₂ [Min ⁻¹]	M₂ [Nm]	f_B	i_{ges}	F_R [kN]	Typ / Type / Tipo / Type / Tipo	Kg ~	mm
7.50	349.4	193	2.5	8.30	5.0	A601 - 132S/2C F601 - 132S/2C	83	132
	389.0	173	2.8	7.45	4.9			
	471.3	143	3.4	6.15	4.6			
	557.7	121	3.9	5.20	4.4			
	602.6	112	4.2	4.81	4.5			
	115.7	601	1.1	8.30	5.0	A601 - 160M/6B F601 - 160M/6B	92	132
	128.8	539	1.2	7.45	5.0			
	156.0	445	1.4	6.15	5.0			
	184.6	376	1.6	5.20	5.0			
	199.5	348	1.8	4.81	5.0			
	224.4	310	2.0	4.28	5.0			
	263.0	264	2.3	3.65	5.0			
	297.5	234	2.6	3.23	5.0			
	392.7	177	3.1	2.44	4.8			
	480.0	145	3.1	2.00	4.6			
28.5	2414	1.4	50.91	22.0	A602 - 132M/4B F602 - 132M/4B	135	134	
32.0	2147	1.5	45.27	22.0				
35.5	1935	1.7	40.81	22.0				
38.2	1802	1.6	38.00	22.0				
42.9	1602	2.0	33.79	22.0				
47.8	1439	2.2	30.35	22.0				
51.1	1345	2.5	28.36	22.0				
56.7	1212	2.7	25.57	22.0				
61.3	1122	2.9	23.66	22.0				
68.5	1004	3.2	21.17	22.0				
74.0	929	3.4	19.59	22.0				
82.4	835	3.8	17.60	22.0				
57.0	1157	2.1	50.91	22.0	A602 - 132S/2C F602 - 132S/2C	126	134	
64.1	1029	2.4	45.27	22.0				
71.1	927	2.7	40.81	22.0				
76.3	863	2.4	38.00	22.0				
85.8	768	3.1	33.79	22.0				
95.5	690	3.5	30.35	21.9				
102.2	644	3.8	28.36	21.6				
21.2	3243	1.0	45.27	22.0	A602 - 160M/6B F602 - 160M/6B	169	134	
23.5	2923	1.1	40.81	22.0				
25.3	2722	1.0	38.00	22.0				
28.4	2420	1.3	33.79	22.0				
31.6	2174	1.5	30.35	22.0				
33.8	2032	1.6	28.36	22.0				
37.5	1831	1.8	25.57	22.0				
40.6	1695	1.9	23.66	22.0				
45.3	1516	2.1	21.17	22.0				
49.0	1403	2.3	19.59	22.0				
54.5	1261	2.5	17.60	22.0				
60.5	1137	2.8	15.87	22.0				
73.1	941	3.3	13.14	22.0				
88.0	781	3.8	10.91	22.0				
97.6	704	4.0	9.83	21.8				
18.1	3714	0.9	79.98	22.0	A603 - 132M/4B F603 - 132M/4B	135	134	
20.8	3244	1.1	69.87	22.0				
26.0	2589	1.4	55.75	22.0				
28.9	2228	1.2	100.21	22.0	A603 - 132S/2C F603 - 132S/2C	126	134	
31.0	2081	1.3	93.60	22.0				
34.4	1875	1.4	84.37	22.0				
36.3	1778	1.5	79.98	22.0				
41.5	1553	1.7	69.87	22.0				
52.0	1239	2.1	55.75	22.0				
185.9	374	2.7	7.80	6.0	A701 - 132M/4B F701 - 132M/4B	95	136	
228.9	303	3.0	6.33	6.0				
274.3	253	3.5	5.29	6.0				
297.9	233	3.7	4.87	6.0				



P_1 [kW]	n_2 [Min ⁻¹]	M_2 [Nm]	f_B	i_{ges}	F_R [kN]	Typ / Type / Tipo / Type / Tipo	 Kg	 mm			
7.50	123.1	564	1.8	7.80	6.0	A701 - 160M/6B F701 - 160M/6B	129	136			
	151.6	458	2.0	6.33	6.0						
	181.6	383	2.3	5.29	6.0						
	197.3	352	2.5	4.87	6.0						
	229.9	302	2.8	4.18	6.0						
	264.3	263	3.2	3.63	6.0						
	300.9	231	3.6	3.19	6.0						
	320.0	217	3.7	3.00	6.0						
	32.5	2118	2.4	44.67	30.0				A702 - 132M/4B F702 - 132M/4B	165	138
	39.6	1736	2.9	36.60	30.0						
43.4	1585	3.2	33.43	30.0							
47.9	1436	3.5	30.27	30.0							
52.0	1322	3.8	27.87	30.0							
64.9	1015	3.7	44.67	30.0	A702 - 132S/2C F702 - 132S/2C	156	138				
21.5	3200	1.6	44.67	30.0	A702 - 160M/6B F702 - 160M/6B	199	138				
26.2	2621	1.9	36.60	30.0							
28.7	2394	2.1	33.43	30.0							
31.7	2168	2.3	30.27	30.0							
34.4	1996	2.5	27.87	30.0							
38.7	1776	2.8	24.80	30.0							
42.0	1636	3.1	22.84	30.0							
46.0	1494	3.3	20.86	30.0							
49.0	1404	3.6	19.60	30.0							
55.9	1231	3.9	17.18	30.0							
13.4	5036	1.0	108.46	30.0	A703 - 132M/4B F703 - 132M/4B	165	138				
14.4	4661	1.1	100.38	30.0							
16.1	4177	1.2	89.95	30.0							
17.4	3870	1.3	83.35	30.0							
19.7	3422	1.5	73.70	30.0							
21.5	3125	1.6	67.31	30.0							
26.0	2588	1.9	55.75	30.0							
31.7	2121	2.4	45.67	30.0							
18.7	3456	1.1	155.48	30.0	A703 - 132S/2C F703 - 132S/2C	156	138				
20.0	3222	1.2	144.94	30.0							
22.6	2853	1.3	128.35	30.0							
24.4	2640	1.4	118.75	30.0							
26.7	2411	1.6	108.46	30.0							
28.9	2231	1.7	100.38	30.0							
32.2	2000	1.9	89.95	30.0							
34.8	1853	2.0	83.35	30.0							
39.3	1638	2.3	73.70	30.0							
43.1	1496	2.5	67.31	30.0							
52.0	1239	3.0	55.75	30.0							
63.5	1015	3.7	45.67	30.0							
13.0	5169	1.0	73.70	30.0				A703 - 160M/6B F703 - 160M/6B	199	138	
14.3	4721	1.1	67.31	30.0							
17.2	3910	1.3	55.75	30.0							
21.0	3203	1.6	45.67	30.0							
22.6	3042	2.6	42.47	55.0	A902 - 160M/6B F902 - 160M/6B	266	140				
25.0	2745	2.9	38.33	55.0							
30.2	2278	3.5	31.81	55.0							
9.4	7154	1.1	154.07	55.0	A903 - 132M/4B F903 - 132M/4B	227	140				
10.4	6473	1.2	139.41	55.0							
11.3	5960	1.3	128.36	55.0							
12.5	5378	1.5	115.83	55.0							
13.9	4848	1.7	104.41	55.0							
15.1	4464	1.8	96.13	55.0							
16.8	4013	2.0	86.43	55.0							
18.3	3674	2.2	79.13	55.0							
20.3	3315	2.4	71.40	55.0							
23.0	2926	2.7	63.02	55.0							
24.5	2751	2.9	59.26	55.0							
27.0	2492	3.2	53.66	55.0							

P₁ [kW]	n₂ [Min ⁻¹]	M₂ [Nm]	f_B	i_{ges}	F_R [kN]	Typ / Type / Tipo / Type / Tipo	Kg ~	mm			
7.50	14.1	4573	1.3	205.73	55.0	A903 - 132S/2C F903 - 132S/2C	223	140			
	15.6	4126	1.5	185.64	55.0						
	18.8	3425	1.8	154.07	55.0						
	20.8	3099	1.9	139.41	55.0						
	22.6	2853	2.1	128.36	55.0						
	25.0	2575	2.3	115.83	55.0						
	27.8	2321	2.6	104.41	55.0						
	30.2	2137	2.8	96.13	55.0						
	33.6	1921	3.1	86.43	55.0						
	36.6	1759	3.4	79.13	55.0						
	40.6	1587	3.8	71.40	55.0						
	8.3	8210	1.0	115.83	55.0				A903 - 160M/6B F903 - 160M/6B	266	140
	9.2	7400	1.1	104.41	55.0						
	10.0	6813	1.2	96.13	55.0						
	11.1	6126	1.3	86.43	55.0						
	12.1	5608	1.4	79.13	55.0						
	13.4	5061	1.6	71.40	55.0						
	15.2	4467	1.8	63.02	55.0						
	16.2	4200	1.9	59.26	55.0						
17.9	3803	2.1	53.66	55.0							
19.8	3437	2.3	48.50	55.0							
9.20	181.1	446	1.3	16.01	9.6	A402 - 132M/2 F402 - 132M/2	90	126			
	200.0	404	1.3	14.50	9.4						
	233.0	347	1.5	12.44	9.2						
	253.1	319	1.5	11.46	9.1						
	315.2	256	1.8	9.20	8.7						
	348.0	232	1.9	8.33	8.5						
	401.7	201	2.1	7.22	8.2						
	500.3	162	2.6	5.80	7.8						
	552.4	146	2.6	5.25	7.6						
	116.5	724	1.0	12.44	9.8				A402 - 132M/4 F402 - 132M/4	90	126
	126.5	667	1.0	11.46	9.8						
	157.6	535	1.1	9.20	9.6						
	174.1	485	1.2	8.33	9.5						
	200.8	420	1.3	7.22	9.3						
	250.0	337	1.6	5.80	9.0						
	276.2	305	1.6	5.25	8.8						
	339.0	244	1.1	8.56	3.8	A501 - 132M/2 F501 - 132M/2	80	128			
	381.6	216	1.2	7.60	3.7						
	470.3	176	1.5	6.17	3.4						
	516.4	160	1.5	5.62	3.3						
	612.7	135	1.8	4.73	3.2						
	714.5	116	2.1	4.06	3.1						
	767.6	108	2.2	3.78	3.0						
	878.8	94	2.5	3.30	2.9						
	1122.6	74	2.9	2.58	2.7						
	1475.4	56	3.1	1.97	2.6						
	1990.2	41	4.0	1.46	2.4						
	2189.8	38	4.0	1.32	2.3						
	235.0	363	0.9	6.17	4.0	A501 - 132M/4 F501 - 132M/4	80	128			
	258.0	330	1.0	5.62	4.0						
	306.6	278	1.2	4.73	3.8						
	357.1	239	1.3	4.06	3.7						
	383.6	222	1.4	3.78	3.6						
	439.4	194	1.6	3.30	3.5						
	562.0	152	1.8	2.58	3.3						
	736.0	116	2.0	1.97	3.1						
	993.2	86	2.6	1.46	2.8						
	1098.5	78	2.6	1.32	2.7						
	74.0	1093	1.1	39.21	14.7				A502 - 132M/2 F502 - 132M/2	107	130
	83.3	971	1.2	34.83	14.6						
	91.9	880	1.4	31.57	14.4						
	102.6	788	1.5	28.26	14.1						
107.5	752	1.6	26.98	14.0							
125.3	645	1.9	23.14	13.7							
133.7	605	2.0	21.69	13.5							
147.5	548	2.2	19.66	13.3							
154.2	524	2.1	18.81	13.1							
172.0	470	2.4	16.86	12.8							



P_1 [kW]	n_2 [Min ⁻¹]	M_2 [Nm]	f_B	i_{ges}	F_R [kN]	Typ / Type / Tipo / Type / Tipo	Kg	mm			
9.20	191.7	422	2.7	15.13	12.5	A502 - 132M/2 F502 - 132M/2	107	130			
	211.6	382	2.7	13.71	12.3						
	258.8	312	2.6	11.20	11.7						
	321.9	251	2.7	9.01	11.0						
	355.2	228	2.6	8.16	10.8						
	384.2	210	2.9	7.55	10.5						
	477.8	169	3.1	6.07	9.9						
	527.2	153	3.4	5.50	9.7						
	51.3	1644	1.0	28.26	14.8				A502 - 132M/4 F502 - 132M/4	107	130
	53.7	1569	1.0	26.98	14.8						
62.7	1346	1.2	23.14	14.7							
66.9	1262	1.3	21.69	14.7							
73.8	1144	1.4	19.66	14.6							
77.1	1094	1.4	18.81	14.5							
86.0	981	1.5	16.86	14.3							
95.8	880	1.7	15.13	14.1							
105.8	798	1.8	13.71	13.9							
129.5	651	1.7	11.20	13.5							
160.9	524	1.7	9.01	12.9							
177.7	475	1.7	8.16	12.7							
192.1	439	1.8	7.55	12.4							
238.9	353	2.0	6.07	11.8							
263.6	320	2.2	5.50	11.6							
349.4	236	2.1	8.30	5.0	A601 - 132M/2 F601 - 132M/2	92	132				
389.3	212	2.3	7.45	4.8							
471.5	175	2.7	6.15	4.6							
557.7	148	3.1	5.20	4.3							
602.9	137	3.4	4.81	4.2							
677.9	122	3.8	4.28	4.0							
174.7	488	1.3	8.30	5.0	A601 - 132M/4 F601 - 132M/4	92	132				
194.6	438	1.5	7.45	5.0							
235.8	361	1.8	6.15	5.0							
278.8	306	2.0	5.20	5.0							
301.5	283	2.2	4.81	5.0							
339.0	251	2.4	4.28	5.0							
397.3	215	2.8	3.65	4.8							
449.3	190	3.2	3.23	4.6							
593.2	144	3.8	2.44	4.3							
725.0	118	3.8	2.00	4.2							
57.0	1419	1.7	50.91	22.0	A602 - 132M/2 F602 - 132M/2	135	134				
64.1	1262	2.0	45.27	22.0							
71.1	1137	2.2	40.81	22.0							
76.3	1059	2.0	38.00	22.0							
85.8	942	2.5	33.79	21.8							
95.6	846	2.8	30.35	21.3							
102.3	790	3.1	28.36	21.0							
113.4	713	3.5	25.57	20.5							
122.6	660	3.8	23.66	20.1							
137.0	590	4.1	21.17	19.6							
28.5	2961	1.1	50.91	22.0	A602 - 132M/4 F602 - 132M/4	135	134				
32.0	2633	1.3	45.27	22.0							
35.5	2374	1.4	40.81	22.0							
38.2	2210	1.3	38.00	22.0							
42.9	1966	1.6	33.79	22.0							
47.8	1765	1.8	30.35	22.0							
51.1	1650	2.0	28.36	22.0							
56.7	1487	2.2	25.57	22.0							
61.3	1376	2.4	23.66	22.0							
68.5	1232	2.6	21.17	22.0							
74.0	1140	2.8	19.59	22.0							
82.4	1024	3.1	17.60	21.9							
91.4	923	3.5	15.87	21.4							
110.4	764	4.1	13.14	20.5							
34.4	2301	1.1	84.37	22.0	A603 - 132M/2 F603 - 132M/2	135	134				
36.3	2181	1.2	79.98	22.0							
41.5	1905	1.4	69.87	22.0							
52.0	1520	1.7	55.75	22.0							

P₁ [kW]	n₂ [Min ⁻¹]	M₂ [Nm]	f_B	i_{ges}	F_R [kN]	Typ / Type / Tipo / Type / Tipo	kg 	mm 	
9.20	26.0	3175	1.1	55.75	22.0	A603 - 132M/4 F603 - 132M/4	135	134	
	371.8 458.1	222 180	3.4 3.7	7.80 6.33	6.0 5.8	A701 - 132M/2 F701 - 132M/2	95	136	
	185.9 229.1 274.3 297.9 347.2 399.3	458 372 311 286 245 213	2.2 2.4 2.8 3.0 3.5 4.0	7.80 6.33 5.29 4.87 4.18 3.63	6.0 6.0 6.0 6.0 6.0 6.0	A701 - 132M/4 F701 - 132M/4	95	136	
	64.9 79.2 86.8	1245 1020 932	3.0 3.7 4.0	44.67 36.60 33.43	30.0 30.0 30.0	A702 - 132M/2 F702 - 132M/2	165	138	
	32.5 39.6 43.4 47.9 52.0 58.5 63.5	2598 2129 1945 1761 1621 1443 1328	1.9 2.3 2.6 2.8 3.1 3.5 3.8	44.67 36.60 33.43 30.27 27.87 24.80 22.84	30.0 30.0 30.0 30.0 30.0 30.0 30.0	A702 - 132M/4 F702 - 132M/4	165	138	
	22.6 24.4 26.7 28.9 32.2 34.8 39.3 43.1 52.0 63.5	3500 3238 2957 2737 2453 2273 2010 1835 1520 1245	1.1 1.2 1.3 1.4 1.5 1.7 1.9 2.0 2.5 3.0	128.35 118.75 108.46 100.38 89.95 83.35 73.70 67.31 55.75 45.67	30.0 30.0 30.0 30.0 30.0 30.0 30.0 30.0 30.0 30.0	A703 - 132M/2 F703 - 132M/2	165	138	
	16.1 17.4 19.7 21.5 26.0 31.7	5123 4747 4198 3834 3175 2601	1.0 1.1 1.2 1.3 1.6 1.9	89.95 83.35 73.70 67.31 55.75 45.67	30.0 30.0 30.0 30.0 30.0 30.0	A703 - 132M/4 F703 - 132M/4	165	138	
	14.1 15.6 18.8 20.8 22.6 25.0 27.8 30.2 33.6 36.6 40.6 46.0 48.9 54.0	5610 5062 4201 3801 3500 3158 2847 2621 2357 2158 1947 1718 1616 1463	1.1 1.2 1.4 1.6 1.7 1.9 2.1 2.3 2.5 2.8 3.1 3.5 3.7 4.1	205.73 185.64 154.07 139.41 128.36 115.83 104.41 96.13 86.43 79.13 71.40 63.02 59.26 53.66	55.0 55.0 55.0 55.0 55.0 55.0 55.0 55.0 55.0 55.0 55.0 54.4 53.5 52.1	A903 - 132M/2 F903 - 132M/2	227	140	
	10.4 11.3 12.5 13.9 15.1 16.8 18.3 20.3 23.0 24.5 27.0	7940 7311 6597 5947 5475 4923 4507 4067 3589 3375 3056	1.0 1.1 1.2 1.3 1.5 1.6 1.8 2.0 2.2 2.4 2.6	139.41 128.36 115.83 104.41 96.13 86.43 79.13 71.40 63.02 59.26 53.66	55.0 55.0 55.0 55.0 55.0 55.0 55.0 55.0 55.0 55.0 55.0	A903 - 132M/4 F903 - 132M/4	227	140	



P_1 [kW]	n_2 [Min ⁻¹]	M_2 [Nm]	f_B	i_{ges}	F_R [kN]	Typ / Type / Tipo / Type / Tipo	Kg	mm
11.0	315.2	307	1.5	9.20	8.4	A402 - 132M/2A F402 - 132M/2A	86	126
	348.0	278	1.6	8.33	8.2			
	401.7	241	1.7	7.22	7.6			
	500.3	193	2.1	5.80	7.5			
	174.0	580	1.0	8.33	8.9	A402 - 132M/4C F402 - 132M/4C	89	126
	200.9	502	1.1	7.22	8.8			
	250.1	403	1.4	5.80	8.6			
	276.2	365	1.4	5.25	8.5			
	470.3	210	1.2	6.17	3.4	A501 - 132M/2A F501 - 132M/2A	75	128
	516.4	191	1.3	5.62	3.3			
612.7	161	1.5	4.73	3.2				
714.5	138	1.7	4.06	3.1				
767.6	129	1.8	3.78	3.0				
878.8	112	2.1	3.30	2.9				
1122.6	88	2.4	2.58	2.7				
1475.4	67	2.6	1.97	2.5				
1990.2	50	3.3	1.46	2.3				
2189.8	45	3.3	1.32	2.2				
306.3	333	1.0	4.73	3.7	A501 - 132M/4C F501 - 132M/4C	78	128	
357.2	285	1.1	4.06	3.6				
383.8	265	1.2	3.78	3.6				
439.4	232	1.3	3.30	3.4				
561.3	182	1.5	2.58	3.2				
737.7	138	1.7	1.97	3.0				
995.1	102	2.1	1.46	2.8				
1094.9	93	2.1	1.32	2.7				
83.3	1161	1.0	34.83	13.7	A502 - 132M/2A F502 - 132M/2A	102	130	
91.9	1052	1.1	31.57	13.6				
102.6	942	1.3	28.26	13.4				
107.5	899	1.3	26.98	13.3				
125.3	771	1.6	23.14	13.1				
133.7	723	1.7	21.69	13.0				
147.5	655	1.8	19.66	12.8				
154.2	627	1.8	18.81	12.7				
172.0	562	2.0	16.86	12.4				
191.7	504	2.2	15.13	12.1				
211.6	457	2.3	13.71	11.9				
258.8	373	2.2	11.20	11.4				
321.9	300	2.2	9.01	10.8				
355.2	272	2.2	8.16	10.6				
384.2	252	2.4	7.55	10.3				
477.8	202	2.6	6.07	9.8				
527.2	183	2.9	5.50	9.5				
62.7	1609	1.0	23.14	13.5	A/F 502 - 132M/4C A/F 502 - 160M/4B	139	130	
66.9	1509	1.1	21.69	13.5				
73.8	1367	1.2	19.66	13.5				
77.1	1308	1.1	18.81	13.5				
86.0	1173	1.3	16.86	13.4				
95.8	1052	1.4	15.13	13.3				
105.8	954	1.5	13.71	13.2				
129.5	779	1.4	11.20	12.9				
160.9	627	1.4	9.01	12.4				
177.7	568	1.4	8.16	12.2				
192.1	525	1.5	7.55	12.0				
238.9	422	1.7	6.07	11.5				
263.6	383	1.8	5.50	11.3				
63.5	1589	0.9	15.13	13.4	A502 - 160L/6B F502 - 160L/6B	152	130	
70.0	1440	1.0	13.71	13.4				
85.7	1177	0.9	11.20	13.4				
106.5	947	1.0	9.01	13.2				
117.6	857	0.9	8.16	13.1				
127.2	793	1.0	7.55	12.9				
158.2	638	1.1	6.07	12.5				
174.5	578	1.2	5.50	12.3				

P_1 [kW]	n_2 [Min ⁻¹]	M_2 [Nm]	f_B	i_{ges}	F_R [kN]	Typ / Type / Tipo / Type / Tipo	 Kg	 mm			
11.0	349.4	283	1.7	8.30	4.9	A601 - 132M/2A F601 - 132M/2A	87	132			
	389.3	254	1.9	7.45	4.8						
	471.5	209	2.3	6.15	4.6						
	557.7	177	2.6	5.20	4.3						
	602.9	164	2.8	4.81	4.2						
	677.6	146	3.1	4.28	4.0						
	794.5	124	3.6	3.65	3.9						
	898.6	110	4.1	3.23	3.9						
	174.7	583	1.1	8.30	5.0				A/F 601 - 132M/4C A/F 601 - 160M/4B	126	132
	194.6	524	1.2	7.45	5.0						
235.8	432	1.5	6.15	5.0							
278.8	365	1.7	5.20	5.0							
301.5	338	1.8	4.81	5.0							
338.8	301	2.0	4.28	4.9							
397.3	257	2.3	3.65	4.7							
449.3	227	2.6	3.23	4.6							
593.2	172	3.2	2.44	4.2							
725.0	141	3.2	2.00	4.0							
156.0	653	1.0	6.15	5.0	A601 - 160L/6B F601 - 160L/6B	139	132				
184.6	552	1.1	5.20	5.0							
199.5	511	1.2	4.81	5.0							
224.4	454	1.3	4.28	5.0							
263.0	387	1.5	3.65	5.0							
297.5	343	1.8	3.23	5.0							
392.7	259	2.1	2.44	4.7							
480.0	212	2.1	2.00	4.5							
693.3	147	3.1	1.38	4.0							
756.9	135	3.0	1.27	3.9							
57.0	1697	1.5	50.91	22.0	A602 - 132M/2A F602 - 132M/2A	130	134				
64.1	1509	1.6	45.27	22.0							
71.1	1360	1.8	40.81	21.8							
76.3	1266	1.7	38.00	21.5							
85.8	1126	2.1	33.79	21.1							
95.5	1011	2.4	30.35	20.6							
102.2	945	2.6	28.36	20.3							
113.4	852	2.9	25.57	19.9							
122.6	789	3.1	23.66	19.6							
137.0	706	3.4	21.17	19.1							
148.0	653	3.7	19.59	18.7							
164.7	587	4.1	17.60	18.3							
38.2	2643	1.1	38.00	22.0				A602 - 132M/4C F602 - 132M/4C	169	134	
32.0	3149	1.0	45.27	22.0				A/F 602 - 132M/4C A/F 602 - 160M/4B	169	134	
35.5	2838	1.2	40.81	22.0							
42.9	2350	1.4	33.79	22.0							
47.8	2111	1.5	30.35	22.0							
51.1	1972	1.7	28.36	22.0							
56.7	1778	1.9	25.57	22.0							
61.3	1646	2.0	23.66	22.0							
68.5	1472	2.2	21.17	21.7							
74.0	1362	2.3	19.59	21.4							
82.4	1224	2.6	17.60	21.1							
91.4	1104	2.9	15.87	20.7							
110.4	914	3.4	13.14	19.9							
132.9	759	4.0	10.91	19.1							
147.5	684	4.1	9.83	18.7							

P_1 [kW]	n_2 [Min ⁻¹]	M_2 [Nm]	f_B	i_{ges}	F_R [kN]	Typ / Type / Tipo / Type / Tipo	Kg	mm
11.0	31.6	3188	1.0	30.35	22.0	A602 - 160L/6B F602 - 160L/6B	182	134
	33.8	2980	1.1	28.36	22.0			
	37.5	2686	1.2	25.57	22.0			
	40.6	2486	1.3	23.66	22.0			
	45.3	2224	1.4	21.17	22.0			
	49.0	2058	1.6	19.59	22.0			
	54.5	1849	1.7	17.60	22.0			
	60.5	1667	1.9	15.87	22.0			
	73.1	1380	2.2	13.14	21.5			
	88.0	1146	2.6	10.91	20.9			
	97.6	1033	2.7	9.83	20.5			
	117.9	855	2.9	8.14	19.7			
	138.8	727	3.2	6.92	19.1			
	154.0	655	3.1	6.24	18.6			
	185.9	542	3.3	5.16	17.8			
41.5	2278	1.2	69.87	22.0	A603 - 132M/2A F603 - 132M/2A	130	134	
52.0	1818	1.4	55.75	22.0				
371.8	266	2.8	7.80	6.0	A701 - 132M/2A F701 - 132M/2A	90	136	
458.1	216	3.1	6.33	5.8				
548.2	180	3.7	5.29	5.5				
595.9	166	3.9	4.87	5.7				
185.9	548	1.8	7.80	6.0	A/F 701 - 132M/4C A/F 701 - 160M/4B	128.5	136	
229.1	445	2.0	6.33	6.0				
274.1	372	2.4	5.29	6.0				
297.9	342	2.5	4.87	6.0				
347.2	294	2.9	4.18	6.0				
399.3	255	3.3	3.63	6.0				
454.5	224	3.7	3.19	5.8				
483.3	211	3.8	3.00	5.7				
123.1	828	1.2	7.80	6.0	A701 - 160L/6B F701 - 160L/6B	129	136	
151.6	672	1.3	6.33	6.0				
181.6	561	1.6	5.29	6.0				
197.3	517	1.7	4.87	6.0				
229.9	443	1.9	4.18	6.0				
264.3	385	2.2	3.63	6.0				
300.9	339	2.4	3.19	6.0				
320.0	318	2.5	3.00	6.0				
381.0	267	3.0	2.52	6.0				
471.9	216	3.5	2.03	5.7				
522.1	195	3.6	1.84	5.9				
64.9	1489	2.5	44.67	30.0				A702 - 132M/2A F702 - 132M/2A
79.2	1220	3.1	36.60	30.0				
86.7	1114	3.4	33.43	30.0				
95.8	1009	3.7	30.27	30.0				
104.0	929	4.0	27.87	30.0				
32.5	3107	1.6	44.67	30.0	A/F 702 - 132M/4C A/F 702 - 160M/4B	199	138	
39.6	2546	2.0	36.60	30.0				
43.4	2325	2.2	33.43	30.0				
47.9	2105	2.4	30.27	30.0				
52.0	1939	2.6	27.87	30.0				
58.5	1725	2.9	24.80	30.0				
63.5	1588	3.1	22.84	30.0				
69.5	1451	3.4	20.86	30.0				
74.0	1363	3.7	19.60	30.0				
84.4	1195	4.0	17.18	30.0				
21.5	4693	1.1	44.67	30.0	A702 - 160L/6B F702 - 160L/6B	199	138	
26.2	3845	1.3	36.60	30.0				
28.7	3512	1.4	33.43	30.0				
31.7	3180	1.6	30.27	30.0				
34.4	2928	1.7	27.87	30.0				
38.7	2605	1.9	24.80	30.0				
42.0	2399	2.1	22.84	30.0				
46.0	2191	2.3	20.86	30.0				
49.0	2059	2.4	19.60	30.0				
55.9	1805	2.7	17.18	30.0				
68.2	1479	3.1	14.08	30.0				
74.7	1351	3.3	12.86	30.0				
91.2	1106	3.6	10.53	30.0				

P_1 [kW]	n_2 [Min ⁻¹]	M_2 [Nm]	f_B	i_{ges}	F_R [kN]	Typ / Type / Tipo / Type / Tipo	 Kg	 mm			
11.0	26.7	3536	1.1	108.46	30.0	A703 - 132M/2A F703 - 132M/2A	160	138			
	28.9	3272	1.1	100.38	30.0						
	32.2	2933	1.3	89.95	30.0						
	34.8	2717	1.4	83.35	30.0						
	39.3	2403	1.6	73.70	30.0						
	43.1	2194	1.7	67.31	30.0						
	52.0	1817	2.1	55.75	30.0						
	63.5	1489	2.5	45.67	30.0						
	19.7	5019	1.0	73.70	30.0				A/F 703 - 132M/4C A/F 703 - 160M/4B	199	138
	21.5	4584	1.1	67.31	30.0						
	26.0	3797	1.3	55.75	30.0						
	31.7	3110	1.6	45.67	30.0						
	21.0	4798	1.0	45.67	30.0	A703 - 160L/6B F703 - 160L/6B	212	138			
	22.6	4462	1.8	42.47	55.0	A902 - 160L/6B F902 - 160L/6B	284	140			
	25.0	4026	2.0	38.33	55.0						
	30.2	3341	2.4	31.81	55.0						
	36.4	2771	2.9	26.38	55.0						
	40.3	2500	3.2	23.80	55.0						
	48.6	2075	3.9	19.75	52.8						
	34.1	2954	2.7	42.47	55.0	A902 - 160M/4B F902 - 160M/4B	266	140			
	37.8	2666	3.0	38.33	55.0						
	45.6	2212	3.6	31.81	53.3						
	18.8	5023	1.2	154.07	55.0	A903 - 132M/2A F903 - 132M/2A	237	140			
	20.8	4545	1.3	139.41	55.0						
	22.6	4185	1.4	128.36	55.0						
	25.0	3776	1.6	115.83	55.0						
	27.8	3404	1.8	104.41	55.0						
30.2	3134	1.9	96.13	55.0							
33.6	2818	2.1	86.43	55.0							
36.6	2580	2.3	79.13	55.0							
40.6	2328	2.6	71.40	55.0							
46.0	2055	2.9	63.02	55.0							
48.9	1932	3.1	59.26	55.0							
54.0	1749	3.4	53.66	55.0							
12.5	7888	1.0	115.83	55.0	A/F 903 - 132M/4C A/F 903 - 160M/4B				266	140	
13.9	7110	1.1	104.41	55.0							
15.1	6547	1.2	96.13	55.0							
16.8	5886	1.4	86.43	55.0							
18.3	5389	1.5	79.13	55.0							
20.3	4862	1.6	71.40	55.0							
23.0	4292	1.9	63.02	55.0							
24.5	4036	2.0	59.26	55.0							
27.0	3654	2.2	53.66	55.0							
12.1	8226	1.0	79.13	55.0	A903 - 160L/6B F903 - 160L/6B	284	140				
13.4	7422	1.1	71.40	55.0							
15.2	6551	1.2	63.02	55.0							
16.2	6160	1.3	59.26	55.0							
17.9	5578	1.4	53.66	55.0							
19.8	5042	1.6	48.50	55.0							
29.9	3303	2.4	48.50	55.0	A903 - 160M/4B F903 - 160M/4B	266	140				
15.0	86.0	1599	0.9	16.86	11.4	A502 - 160L/4A F502 - 160L/4A	148	130			
	95.8	1435	1.0	15.13	11.6						
	105.8	1300	1.1	13.71	11.6						
	129.5	1062	1.0	11.20	11.6						
	160.9	855	1.1	9.01	11.4						
	177.7	774	1.0	8.16	11.3						
	192.1	716	1.1	7.55	11.2						
	238.9	576	1.2	6.07	10.8						
	263.6	522	1.3	5.50	10.6						



P_1 [kW]	n_2 [Min ⁻¹]	M_2 [Nm]	f_B	i_{ges}	F_R [kN]	Typ / Type / Tipo / Type / Tipo	Kg ~	mm
15.0	235.8	589	1.1	6.15	5.0	A601 - 160L/4A F601 - 160L/4A	135	132
	278.8	498	1.2	5.20	5.0			
	301.5	461	1.3	4.81	4.9			
	338.8	410	1.5	4.28	4.7			
	397.3	350	1.7	3.65	4.6			
	448.9	310	1.9	3.23	4.4			
	593.2	234	2.3	2.44	4.1			
	725.0	192	2.3	2.00	3.9			
	1047.2	133	3.4	1.38	3.5			
	1143.3	122	3.3	1.27	3.4			
	225.6	616	1.0	4.28	5.0	A601 - 180L/6A F601 - 180L/6A	167	132
	264.4	526	1.1	3.65	5.0			
	299.0	465	1.3	3.23	4.9			
	394.8	352	1.6	2.44	4.6			
	482.5	288	1.6	2.00	4.3			
	696.9	199	2.3	1.38	3.9			
	760.9	183	2.2	1.27	3.8			
		42.9	3205	1.0	33.79			
47.8		2878	1.1	30.35	19.6			
51.1		2690	1.2	28.36	19.6			
56.7		2425	1.4	25.57	19.7			
61.3		2244	1.5	23.66	19.7			
68.5		2008	1.6	21.17	19.6			
74.0		1858	1.7	19.59	19.5			
82.4		1669	1.9	17.60	19.3			
91.4		1505	2.1	15.87	19.1			
110.4		1246	2.5	13.14	18.6			
132.9		1035	2.9	10.91	18.0			
147.5		932	3.0	9.83	17.7			
178.1		772	3.2	8.14	17.0			
209.5		656	3.5	6.92	16.5			
232.4		592	3.4	6.24	16.1			
281.0	489	3.7	5.16	15.4				
	40.8	3372	1.0	23.66	19.0	A602 - 180L/6A F602 - 180L/6A	210	134
	45.6	3017	1.1	21.17	19.3			
	49.3	2792	1.1	19.59	19.5			
	54.8	2508	1.3	17.60	19.6			
	60.8	2262	1.4	15.87	19.6			
	73.4	1873	1.7	13.14	19.4			
	88.5	1555	1.9	10.91	19.1			
	98.2	1401	2.0	9.83	18.9			
	118.6	1160	2.2	8.14	18.4			
	139.5	986	2.3	6.92	18.0			
	154.6	889	2.2	6.24	17.6			
	187.0	735	2.4	5.16	17.0			
		185.9	747	1.3	7.80			
229.1		607	1.5	6.33	6.0			
274.1		507	1.7	5.29	6.0			
297.7		467	1.9	4.87	6.0			
346.9		401	2.1	4.18	6.0			
399.3		348	2.4	3.63	5.9			
454.5		306	2.7	3.19	5.7			
483.3		287	2.8	3.00	5.6			
575.4		241	3.3	2.52	5.3			
712.7		195	3.8	2.03	5.3			
788.6		176	4.0	1.84	5.1			
	152.4	912	1.0	6.33	6.0	A701 - 180L/6A F701 - 180L/6A	170	136
	182.6	761	1.2	5.29	6.0			
	198.3	701	1.2	4.87	6.0			
	231.1	601	1.4	4.18	6.0			
	265.7	523	1.6	3.63	6.0			
	302.5	459	1.8	3.19	6.0			
	321.7	432	1.9	3.00	6.0			
	382.9	363	2.2	2.52	6.0			
	474.3	293	2.6	2.03	5.6			
	524.8	265	2.6	1.84	5.5			
	668.1	208	3.4	1.44	5.1			
	768.1	181	3.6	1.26	5.2			

P_1 [kW]	n_2 [Min ⁻¹]	M_2 [Nm]	f_B	i_{ges}	F_R [kN]	Typ / Type / Tipo / Type / Tipo	 Kg	 mm				
15.0	32.5	4237	1.2	44.67	30.0	A702 - 160L/4A F702 - 160L/4A	208	138				
	39.6	3471	1.4	36.60	30.0							
	43.4	3171	1.6	33.43	30.0							
	47.9	2871	1.7	30.27	30.0							
	52.0	2643	1.9	27.87	30.0							
	58.5	2352	2.1	24.80	30.0							
	63.5	2166	2.3	22.84	30.0							
	69.5	1978	2.5	20.86	30.0							
	74.0	1859	2.7	19.60	30.0							
	84.4	1630	2.9	17.18	30.0							
	103.0	1335	3.4	14.08	29.8							
	112.8	1219	3.6	12.86	29.2							
	137.7	999	4.0	10.53	27.8							
	15.0	26.4	5216	1.0	36.60				30.0	A702 - 180L/6A F702 - 180L/6A	240	138
		28.9	4764	1.0	33.43				30.0			
31.9		4314	1.2	30.27	30.0							
34.6		3972	1.3	27.87	30.0							
38.9		3535	1.4	24.80	30.0							
42.3		3254	1.5	22.84	30.0							
46.3		2972	1.7	20.86	30.0							
49.2		2793	1.8	19.60	30.0							
56.2		2449	2.0	17.18	30.0							
68.6		2006	2.3	14.08	30.0							
75.1		1832	2.4	12.86	30.0							
91.6		1501	2.7	10.53	30.0							
111.8		1230	3.1	8.63	29.5							
122.5		1123	3.3	7.88	28.8							
134.1		1025	3.5	7.20	28.2							
15.0	163.7	840	3.8	5.90	26.8	A703 - 160L/4A F703 - 160L/4A	208	138				
	179.2	767	3.9	5.38	26.2							
	26.0	5177	1.0	55.75	30.0							
	31.7	4241	1.2	45.67	30.0							
	15.0	34.1	4028	2.0	42.47				53.6	A902 - 160L/4A F902 - 160L/4A	284	140
		37.8	3635	2.2	38.33				52.6			
		45.6	3017	2.7	31.81				50.7			
		55.0	2502	3.2	26.38				48.7			
		60.9	2257	3.5	23.80				47.6			
	15.0	22.7	6052	1.3	42.47				55.0	A902 - 180L/6A F902 - 180L/6A	305	140
		25.2	5462	1.5	38.33				55.0			
		30.3	4533	1.8	31.81				54.8			
		36.6	3759	2.1	26.38				53.1			
		40.5	3392	2.4	23.80				52.2			
		48.9	2815	2.8	19.75				50.3			
56.2		2448	3.2	17.18	48.8							
15.0	62.3	2209	3.5	15.50	47.7	A903 - 160L/4A F903 - 160L/4A	284	140				
	75.0	1833	4.0	12.86	45.7							
	16.8	8026	1.0	86.43	55.0							
	18.3	7348	1.1	79.13	55.0							
	20.3	6631	1.2	71.40	55.0							
	23.0	5852	1.4	63.02	55.0							
	24.5	5503	1.5	59.26	55.0							
15.0	27.0	4983	1.6	53.66	55.0	A903 - 180L/6A F903 - 180L/6A	305	140				
	29.9	4504	1.8	48.50	54.9							
	16.3	8269	1.0	59.26	55.0							
18.5	18.0	7488	1.1	53.66	55.0	A601 - 180M/4B F601 - 180M/4B	171	132				
	19.9	6768	1.2	48.50	55.0							
	278.8	615	1.0	5.20	4.8							
	301.5	568	1.1	4.81	4.8							
	338.8	506	1.2	4.28	4.6							
	397.3	431	1.4	3.65	4.5							
	448.9	382	1.6	3.23	4.3							
	594.3	288	1.9	2.44	4.0							
	725.0	236	1.9	2.00	3.8							
	1050.7	163	2.8	1.38	3.5							
1141.7	150	2.7	1.27	3.4								

P_1 [kW]	n_2 [Min ⁻¹]	M_2 [Nm]	f_B	i_{ges}	F_R [kN]	Typ / Type / Tipo / Type / Tipo	Kg	mm				
18.5	51.1	3317	1.0	28.36	17.1	A602 - 180M/4B F602 - 180M/4B	214	134				
	56.7	2991	1.1	25.57	17.4							
	61.3	2768	1.2	23.66	17.6							
	68.5	2476	1.3	21.17	17.7							
	74.0	2291	1.4	19.59	17.7							
	82.4	2059	1.6	17.60	17.7							
	91.4	1856	1.7	15.87	17.7							
	110.4	1537	2.0	13.14	17.4							
	132.9	1276	2.4	10.91	17.1							
	147.5	1150	2.4	9.83	16.8							
	178.1	952	2.6	8.14	16.3	A701 - 180M/4B F701 - 180M/4B	174	136				
	209.5	809	2.8	6.92	15.8							
	232.4	730	2.7	6.24	15.5							
	281.0	604	3.0	5.16	14.9							
	185.9	922	1.1	7.80	6.0							
	229.1	748	1.2	6.33	6.0							
	274.1	625	1.4	5.29	6.0							
	297.7	576	1.5	4.87	6.0							
	346.9	494	1.7	4.18	6.0							
	399.4	429	2.0	3.63	5.9							
	454.5	377	2.2	3.19	5.6	A701 - 200L/6B F701 - 200L/6B	219	136				
	483.3	355	2.3	3.00	5.5							
	575.4	298	2.7	2.52	5.3							
	712.7	240	3.1	2.03	4.9							
	788.6	217	3.2	1.84	4.8							
	199.3	860	1.0	4.87	6.0							
	232.3	738	1.2	4.18	6.0							
	267.1	642	1.3	3.63	6.0							
	304.0	564	1.5	3.19	6.0							
	323.3	530	1.5	3.00	6.0							
	384.9	445	1.8	2.52	5.9	A702 - 180M/4B F702 - 180M/4B	244	138				
	476.8	359	2.1	2.03	5.6							
	527.5	325	2.2	1.84	5.4							
	671.5	255	2.7	1.44	5.0							
	772.0	222	2.9	1.26	4.8							
	32.5	5225	1.0	44.67	30.0							
	39.6	4281	1.2	36.60	30.0							
	43.4	3910	1.3	33.43	30.0							
	47.9	3541	1.4	30.27	30.0							
	52.0	3260	1.5	27.87	30.0							
	58.5	2901	1.7	24.80	30.0	A702 - 200L/6B F702 - 200L/6B	289	138				
	63.5	2672	1.9	22.84	30.0							
	69.5	2440	2.0	20.86	30.0							
	74.0	2293	2.2	19.60	30.0							
	84.4	2010	2.4	17.18	30.0							
	103.0	1647	2.8	14.08	28.8							
	112.8	1504	2.9	12.86	28.3							
	137.7	1232	3.2	10.53	27.0							
	168.0	1009	3.8	8.63	25.8							
		184.0	922	4.0	7.88				25.2	A703 - 180M/4B F703 - 180M/4B	244	138
34.8		4873	1.0	27.87	30.0							
42.5		3994	1.3	22.84	30.0							
46.5		3647	1.4	20.86	30.0							
49.5		3427	1.5	19.60	30.0							
56.5		3004	1.6	17.18	30.0							
68.9		2462	1.9	14.08	30.0							
75.4		2249	2.0	12.86	30.0							
		92.1	1841	2.2	10.53	29.6	A703 - 180M/4B F703 - 180M/4B	244	138			
		112.4	1509	2.5	8.63	28.5						
	123.1	1378	2.7	7.88	27.9							
	134.7	1259	2.9	7.20	27.4							
	164.4	1032	3.1	5.90	26.1							
	180.3	941	3.2	5.38	25.6							
	31.7	5231	1.0	45.67	30.0							

P₁ [kW]	n₂ [Min ⁻¹]	M₂ [Nm]	f_B	i_{ges}	F_R [kN]	Typ / Type / Tipo / Type / Tipo	Kg ~	mm			
18.5	34.1	4968	1.6	42.47	50.6	A902 - 180M/4B F902 - 180M/4B	309	140			
	37.8	4483	1.8	38.33	49.9						
	45.6	3721	2.2	31.81	48.5						
	55.0	3085	2.6	26.38	46.9						
	60.9	2784	2.9	23.80	46.0						
	73.4	2310	3.5	19.75	44.2						
	84.4	2009	3.9	17.18	42.8						
	22.8	7427	1.1	42.47	52.1				A902 - 200L/6B F902 - 200L/6B	360	140
	25.3	6701	1.2	38.33	51.9						
	30.5	5562	1.4	31.81	51.3						
	36.8	4612	1.7	26.38	50.3						
	40.8	4162	1.9	23.80	49.6						
	49.1	3454	2.3	19.75	48.1						
	56.5	3004	2.6	17.18	46.9						
	62.6	2710	2.9	15.50	46.0						
	75.4	2249	3.2	12.86	44.3						
	94.4	1797	4.0	10.28	42.1						
	104.6	1622	4.0	9.28	41.1						
	126.0	1346	3.9	7.70	39.2						
	140.8	1205	4.2	6.89	38.2						
	20.3	8178	1.0	71.40	52.9	A903 - 180M/4B F903 - 180M/4B	309	140			
	23.0	7218	1.1	63.02	52.7						
	24.5	6787	1.2	59.26	52.6						
	27.0	6146	1.3	53.66	52.2						
	29.9	5555	1.4	48.50	51.7						
	22.0	398.6	511	1.2	3.65	4.4	A601 - 180L/4B F601 - 180L/4B	179	132		
		450.8	452	1.3	3.23	4.2					
		596.3	342	1.6	2.44	4.0					
		727.5	280	1.6	2.00	3.8					
		1054.3	193	2.3	1.38	3.4					
		1145.7	178	2.2	1.27	3.3					
		61.5	3280	1.0	23.66	15.5	A602 - 180L/4B F602 - 180L/4B	222	134		
		68.7	2935	1.1	21.17	15.8					
74.3		2716	1.2	19.59	16.0						
82.7		2440	1.3	17.60	16.2						
91.7		2200	1.5	15.87	16.3						
110.7		1822	1.7	13.14	16.3						
133.4		1512	2.0	10.91	16.1						
148.0		1363	2.1	9.83	16.0						
178.7		1128	2.2	8.14	15.6						
210.3		959	2.4	6.92	15.2						
233.2		865	2.3	6.24	15.0						
282.0		715	2.5	5.16	14.5						
229.9		887	1.0	6.33	6.0	A701 - 180L/4B F701 - 180L/4B	182	136			
275.0		741	1.2	5.29	6.0						
298.8		682	1.3	4.87	6.0						
348.1		585	1.5	4.18	6.0						
400.8		508	1.7	3.63	5.8						
456.1		447	1.8	3.19	5.6						
485.0		420	1.9	3.00	5.5						
577.4		353	2.3	2.52	5.2						
716.7		284	2.6	2.03	4.9						
790.8		258	2.7	1.84	4.8						
1007.3		202	3.5	1.44	4.4						
1158.1		176	3.7	1.26	4.2						
232.3		877	1.0	4.18	6.0				A701 - 200L/6C F701 - 200L/6C	229	136
267.1		763	1.1	3.63	6.0						
304.0		670	1.2	3.19	6.0						
323.3	630	1.3	3.00	6.0							
384.9	529	1.5	2.52	5.8							
476.8	427	1.8	2.03	5.5							
527.5	386	1.8	1.84	5.3							
671.5	303	2.3	1.44	5.0							
772.0	264	2.5	1.26	4.8							

P₁ [kW]	n₂ [Min ⁻¹]	M₂ [Nm]	f_B	i_{ges}	F_R [kN]	Typ / Type / Tipo / Type / Tipo	Kg ~	mm					
22.0	39.8	5074	1.0	36.60	30.0	A702 - 180L/4B F702 - 180L/4B	252	138					
	43.5	4634	1.1	33.43	30.0								
	48.1	4196	1.2	30.27	30.0								
	52.2	3863	1.3	27.87	30.0								
	58.7	3438	1.5	24.80	29.9								
	63.7	3166	1.6	22.84	29.7								
	69.8	2892	1.7	20.86	29.4								
	74.2	2717	1.8	19.60	29.2								
	84.7	2382	2.0	17.18	28.7								
	103.3	1952	2.4	14.08	27.8								
	113.1	1783	2.5	12.86	27.3								
	138.2	1460	2.7	10.53	26.3								
	168.6	1196	3.2	8.63	25.2								
	184.6	1092	3.4	7.88	24.7								
	202.1	998	3.6	7.20	24.1								
	246.6	818	3.9	5.90	23.0								
	270.4	746	4.0	5.38	22.4								
		42.5	4749	1.1	22.84	30.0	A702 - 200L/6C F702 - 200L/6C	299	138				
		46.5	4338	1.2	20.86	30.0							
		49.5	4076	1.2	19.60	30.0							
		56.5	3572	1.3	17.18	30.0							
		68.9	2928	1.6	14.08	29.5							
		75.4	2674	1.6	12.86	29.2							
		92.1	2190	1.8	10.53	28.4							
		112.4	1794	2.1	8.63	27.5							
		123.1	1639	2.3	7.88	27.0							
		134.7	1497	2.4	7.20	26.5							
		164.4	1227	2.6	5.90	25.5							
		180.3	1119	2.7	5.38	25.0							
			34.3	5888	1.4	42.47				47.7	A902 - 180L/4B F902 - 180L/4B	317	140
			38.0	5313	1.5	38.33				47.3			
	45.7		4410	1.8	31.81	46.3							
	55.2		3657	2.2	26.38	45.1							
	61.1		3299	2.4	23.80	44.3							
73.7	2738		2.9	19.75	42.8								
84.7	2381		3.3	17.18	41.6								
93.9	2149		3.6	15.50	40.7								
113.1	1783		4.1	12.86	39.1								
	25.3		7970	1.0	38.33	47.3	A902 - 200L/6C F902 - 200L/6C	370	140				
	30.5	6614	1.2	31.81	46.3								
	36.8	5485	1.5	26.38	45.1								
	40.8	4949	1.6	23.80	44.3								
	49.1	4107	1.9	19.75	46.0								
	56.5	3572	2.2	17.18	45.1								
	62.6	3223	2.4	15.50	44.3								
	75.4	2675	2.7	12.86	42.9								
	94.4	2137	3.4	10.28	41.0								
	104.6	1929	3.4	9.28	40.1								
	126.0	1601	3.3	7.70	38.4								
	140.8	1433	3.5	6.89	37.4								
	156.0	1293	3.8	6.22	36.5								
		23.1	8554	0.9	63.02	48.5				A903 - 180L/4B F903 - 180L/4B	317	140	
24.6		8044	1.0	59.26	48.6								
27.1		7284	1.1	53.66	48.6								
30.0		6583	1.2	48.50	48.4								
30.0	299.8	927	0.9	4.87	6.0	A701 - 200L/4C F701 - 200L/4C	240	136					
	349.3	796	1.1	4.18	5.8								
	402.2	691	1.2	3.63	5.6								
	457.7	607	1.4	3.19	5.4								
	486.7	571	1.4	3.00	5.3								
	579.4	480	1.7	2.52	5.1								
	719.2	386	1.9	2.03	4.8								
	793.5	350	2.0	1.84	4.7								
	1013.9	274	2.6	1.44	4.3								
	1158.7	240	2.7	1.26	4.2								

P_1 [kW]	n_2 [Min ⁻¹]	M_2 [Nm]	f_B	i_{ges}	F_R [kN]	Typ / Type / Tipo / Type / Tipo	 Kg	 mm			
30.0	52.4	5250	1.0	27.87	25.5	A702 - 200L/4C F702 - 200L/4C	310	138			
	63.9	4303	1.2	22.84	25.9						
	70.0	3930	1.3	20.86	26.0						
	74.5	3692	1.4	19.60	26.0						
	85.0	3236	1.5	17.18	25.8						
	103.7	2652	1.7	14.08	25.5						
	113.5	2423	1.8	12.86	25.2						
	138.7	1984	2.0	10.53	24.5						
	169.2	1626	2.3	8.63	23.7						
	185.3	1484	2.5	7.88	23.3						
	202.8	1356	2.7	7.20	22.9						
	247.5	1111	2.9	5.90	22.0						
	271.4	1014	3.0	5.38	21.5						
	34.4	8001	1.0	42.47	40.9				A902 - 200L/4C F902 - 200L/4C	381	140
	38.1	7221	1.1	38.33	41.2						
	45.9	5992	1.3	31.81	41.3						
	55.3	4970	1.6	26.38	40.9						
	61.3	4484	1.8	23.80	40.5						
	73.9	3721	2.2	19.75	39.7						
	85.0	3236	2.4	17.18	38.9						
94.2	2920	2.7	15.50	38.3							
113.5	2423	3.0	12.86	37.0							
142.0	1936	3.7	10.28	35.4							
157.4	1747	3.7	9.28	34.6							
189.7	1450	3.7	7.70	33.1							
211.9	1298	3.9	6.89	32.3							
234.8	1171	4.2	6.22	31.5							
37.0	45.9	7391	1.1	31.81	36.8	A902 - 225S/4A F902 - 225S/4A	431	140			
	55.3	6129	1.3	26.38	37.2						
	61.3	5530	1.4	23.80	37.2						
	73.9	4589	1.7	19.75	36.9						
	85.0	3992	2.0	17.18	36.5						
	94.2	3601	2.2	15.50	36.1						
	113.5	2988	2.4	12.86	35.2						
	142.0	2388	3.0	10.28	33.9						
	157.3	2156	3.0	9.28	33.3						
	189.6	1789	3.0	7.70	32.1						
	211.9	1601	3.1	6.89	31.3						
	234.7	1445	3.4	6.22	30.6						
	282.9	1199	3.8	5.16	29.3						
	45.0	55.3	7454	1.1	26.38				33.0	A902 - 225M/4C F902 - 225M/4C	468
61.3		6725	1.2	23.80	33.4						
73.9		5581	1.4	19.75	33.8						
85.0		4855	1.6	17.18	33.8						
94.2		4380	1.8	15.50	33.6						
113.5		3634	2.0	12.86	33.2						
142.0		2905	2.5	10.28	32.3						
157.3		2622	2.5	9.28	31.8						
189.6		2176	2.4	7.70	30.8						
211.9		1947	2.6	6.89	30.2						
234.7		1758	2.8	6.22	29.6						
282.9		1458	3.2	5.16	28.5						



A large area of the page is filled with horizontal dotted lines, providing a template for writing or drawing.

Maßtabelle

Dimension Tables

Dimensione Tabelle

Tables De Dimension

Tablas De Dimensiones

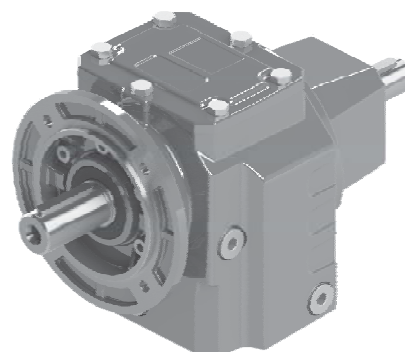
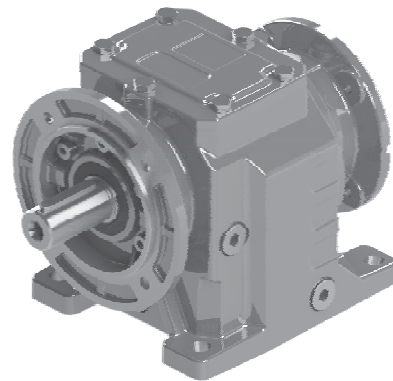
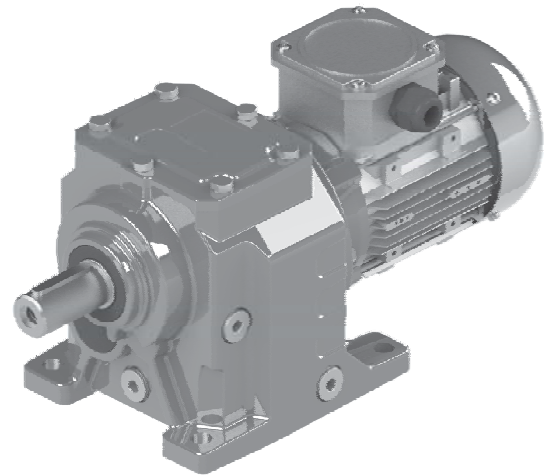

A/F 301 ... 701

A/F 202 ... 902

A/F 253 ... 903

A/F

A 202

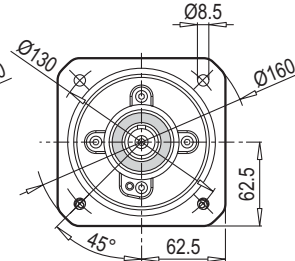
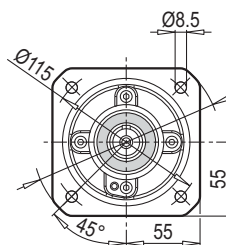
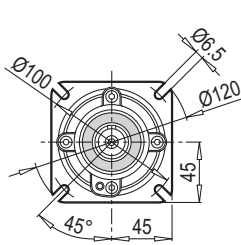
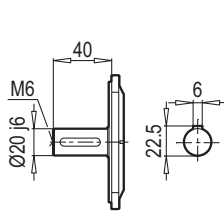
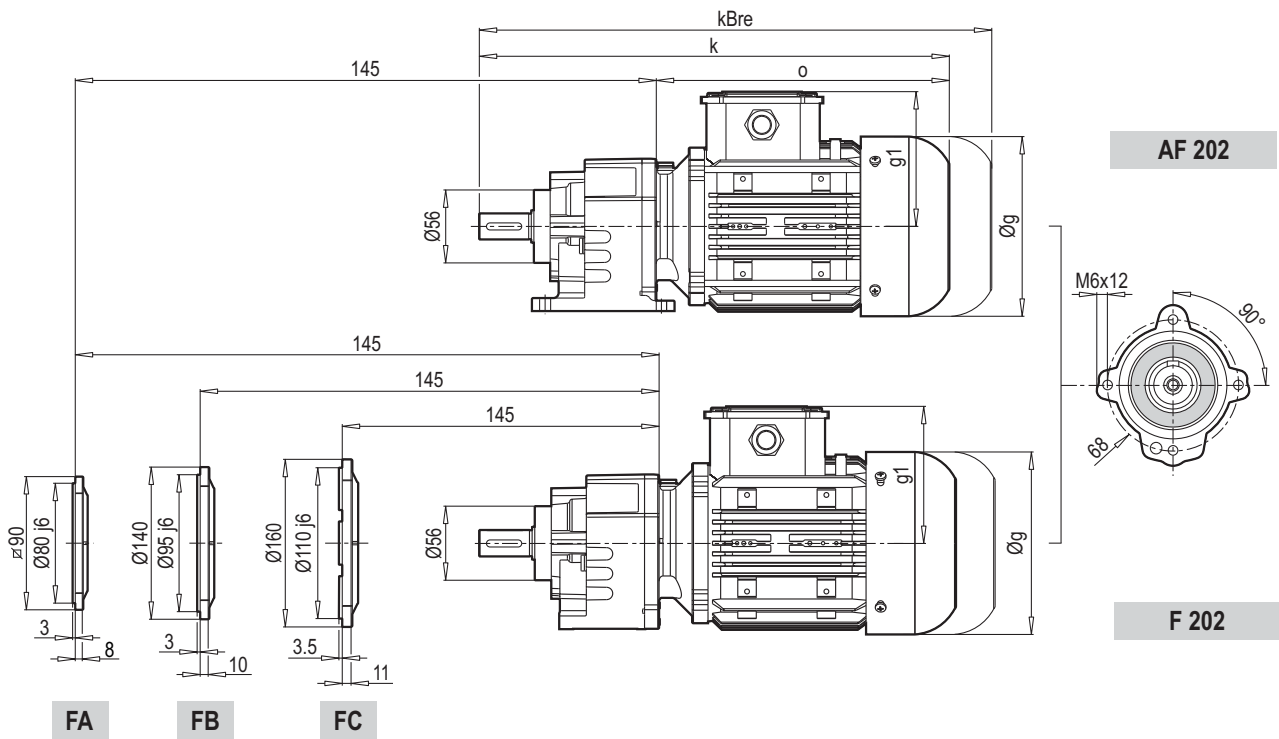
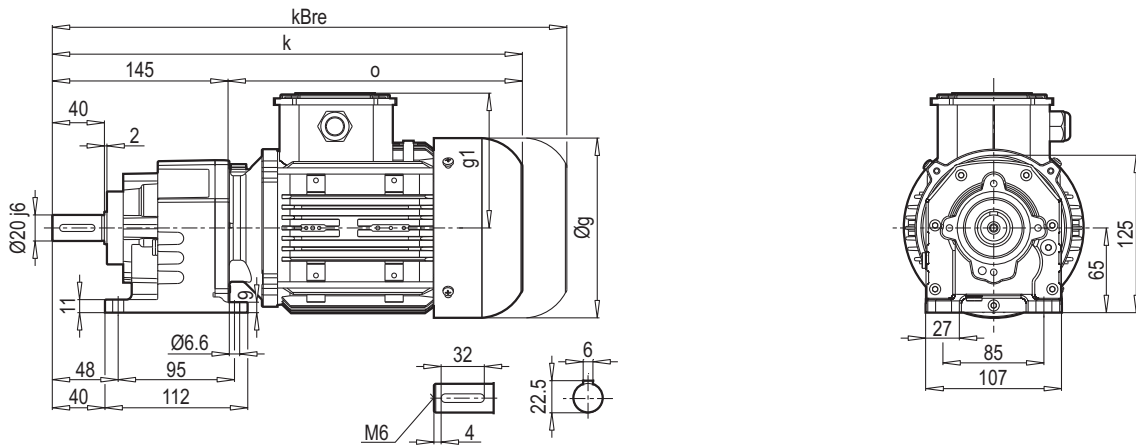

(A/F 202 - F202) **FA**

(F202) **FB**

(F202) **FC**

	63 M	71 M					
g	124	140					
g1	111	119					
k	342	368					
kBre	394	428					
o	197	223					

A 202 PAM B5/B14

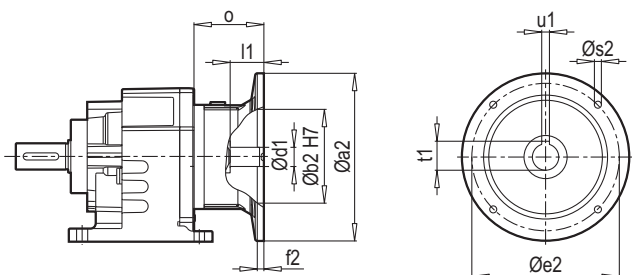

F 202 PAM B5/B14

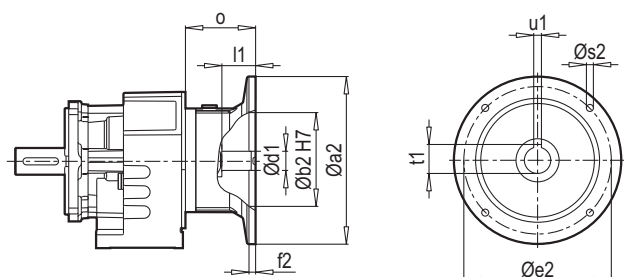

AF 202 PAM B5/B14

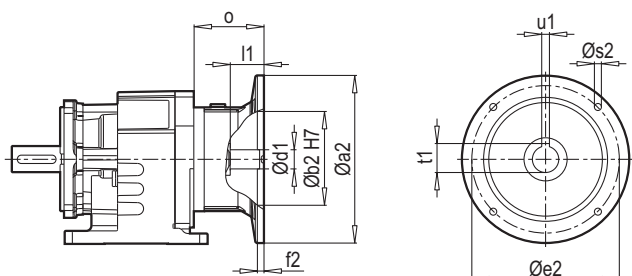

Typ / Type / Tipo Type / Tipo	PAM B5	Øa2	Øb2	Øe2	f2	Øs2	Ød1	l1	t1	u1	o
A/F 202	56	120	80	100	3.5	M6	9	20	10.2	3	29.5
	63	140	95	115	3.5	M8	11	23	12.8	4	59.5

~ kg	
PAM B5	A/F 202
56	5
63	5

Typ / Type / Tipo Type / Tipo	PAM B14	Øa2	Øb2	Øe2	f2	Øs2	Ød1	l1	t1	u1	o
A/F 202	56	80	50	65	3	6	9	20	10.4	3	32.5
	63	90	60	75	2.5	6	11	23	12.8	4	59.5
	71	105	70	85	2.5	7	14	30	16.3	5	59.5

~ kg	
PAM B14	A/F 202
56	4
63	4
71	5

A 202 G

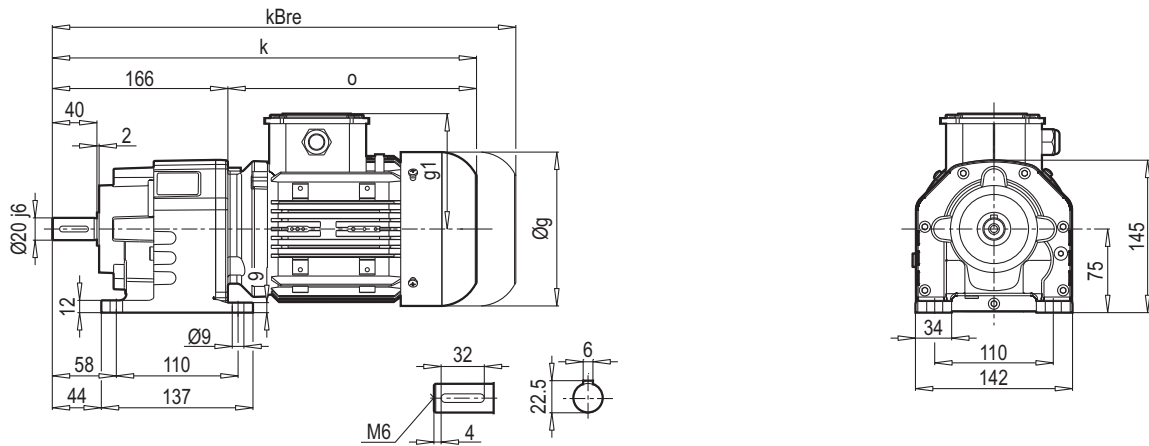

AF 202 G

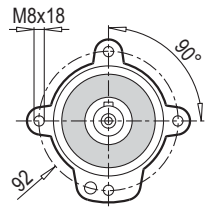
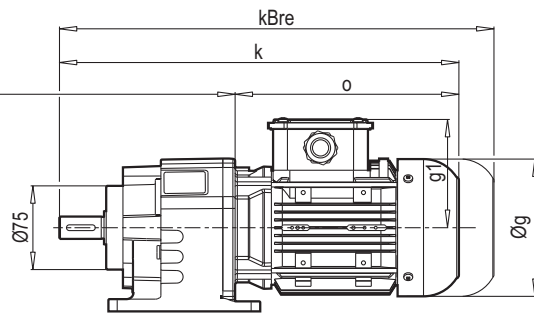

F 202 G

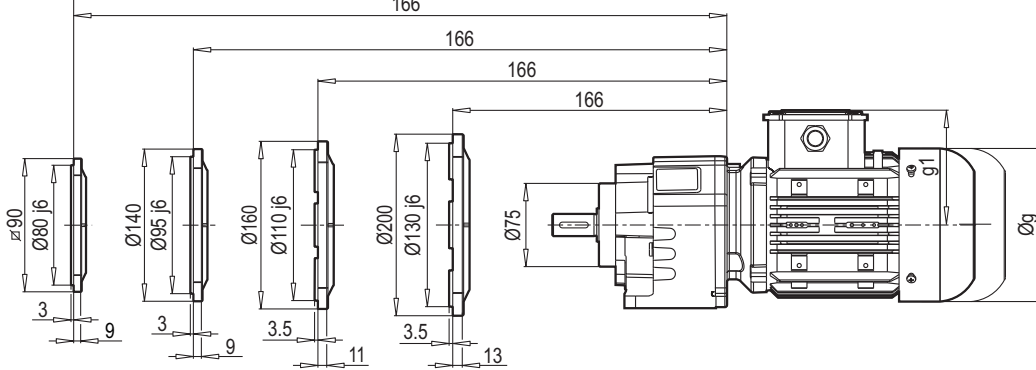

FA

FB

FC

FD

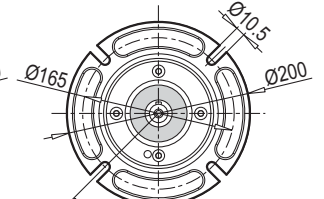
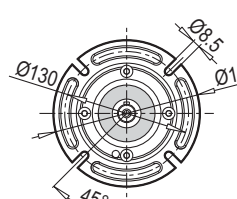
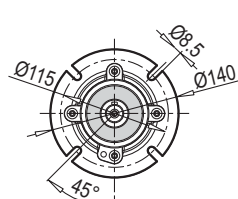
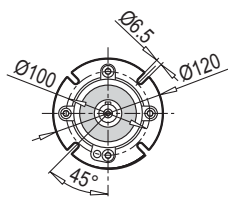
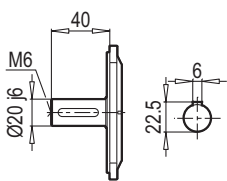

FA

FB

FC

FD

	63 M	71 M	80 M	90 S	90 L			
g	124	140	159	193	193			
g1	111	119	127	151	151			
k	378	407	433	479	499			
kBre	430	467	495	552	572			
o	212	241	267	313	333			

A 202 G PAM B5/B14

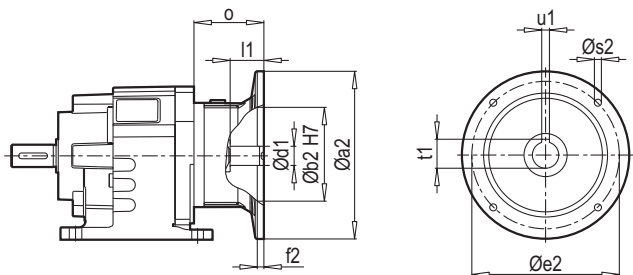

A 202 G W

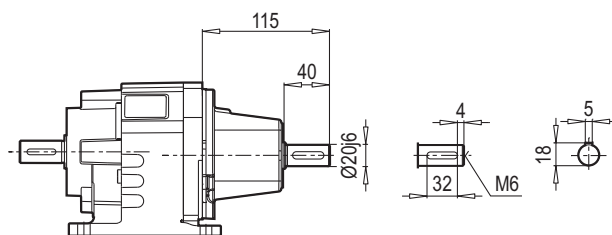

F 202 G PAM B5/B14

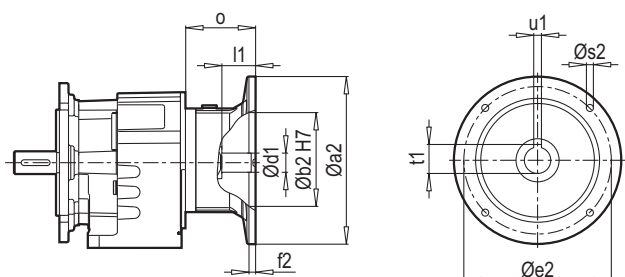

F 202 G W

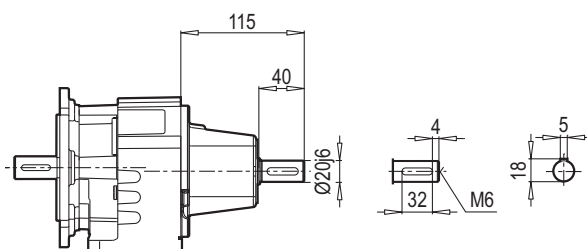

AF 202 G PAM B5/B14

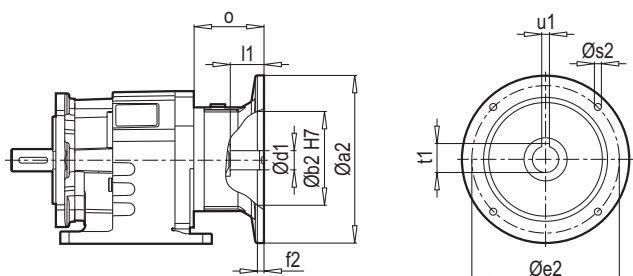

AF 202 G W

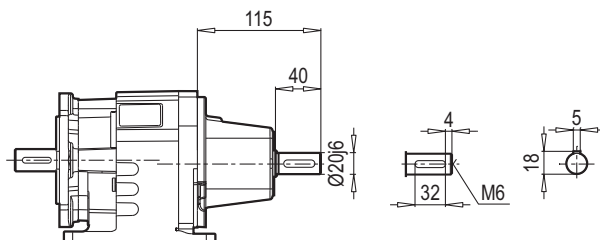

Typ / Type / Tipo Type / Tipo	PAM B5	Øa2	Øb2	Øe2	f2	Øs2	Ød1	l1	t1	u1	o
A/F 202 G	56	120	80	100	3.5	M6	9	20	10.2	3	29.5
	63	140	95	115	3.5	M8	11	23	12.8	4	74.5
	71	160	110	130	4	M8	14	30	16.3	5	74.5
	80	200	130	165	4	M10	19	40	21.8	6	74.5
	90	200	130	165	4	M10	24	50	27.3	8	87.5

~ Kg	
PAM B5	A/F 202 G
56	8
63	8
71	8
80	8
90	8

Typ / Type / Tipo Type / Tipo	PAM B14	Øa2	Øb2	Øe2	f2	Øs2	Ød1	l1	t1	u1	o
A/F 202 G	56	80	50	65	3	6	9	20	10.4	3	32.5
	63	90	60	75	2.5	6	11	23	12.8	4	74.5
	71	105	70	85	2.5	7	14	30	16.3	5	74.5
	80	120	80	100	3	7	19	40	21.8	6	74.5
	90	140	95	115	3	9	24	50	27.3	8	87.5

~ Kg	
PAM B14	A/F 202 G
56	6
63	6
71	7
80	8
90	8

A 252-253

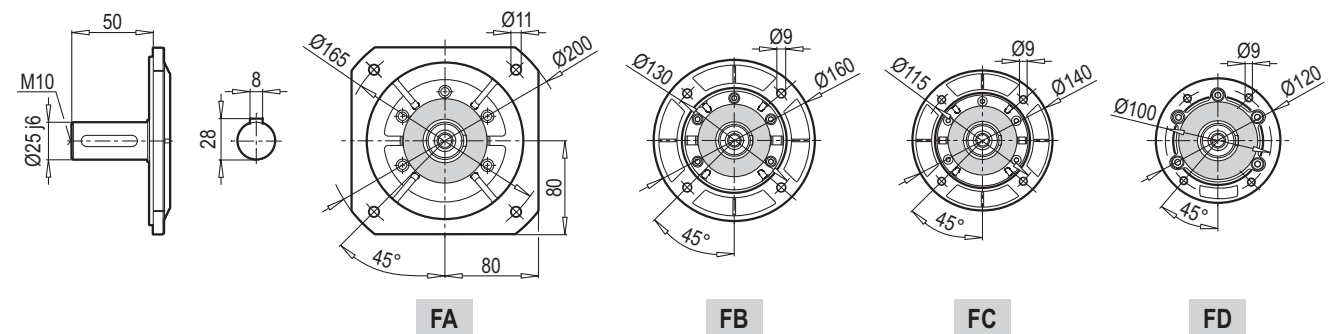
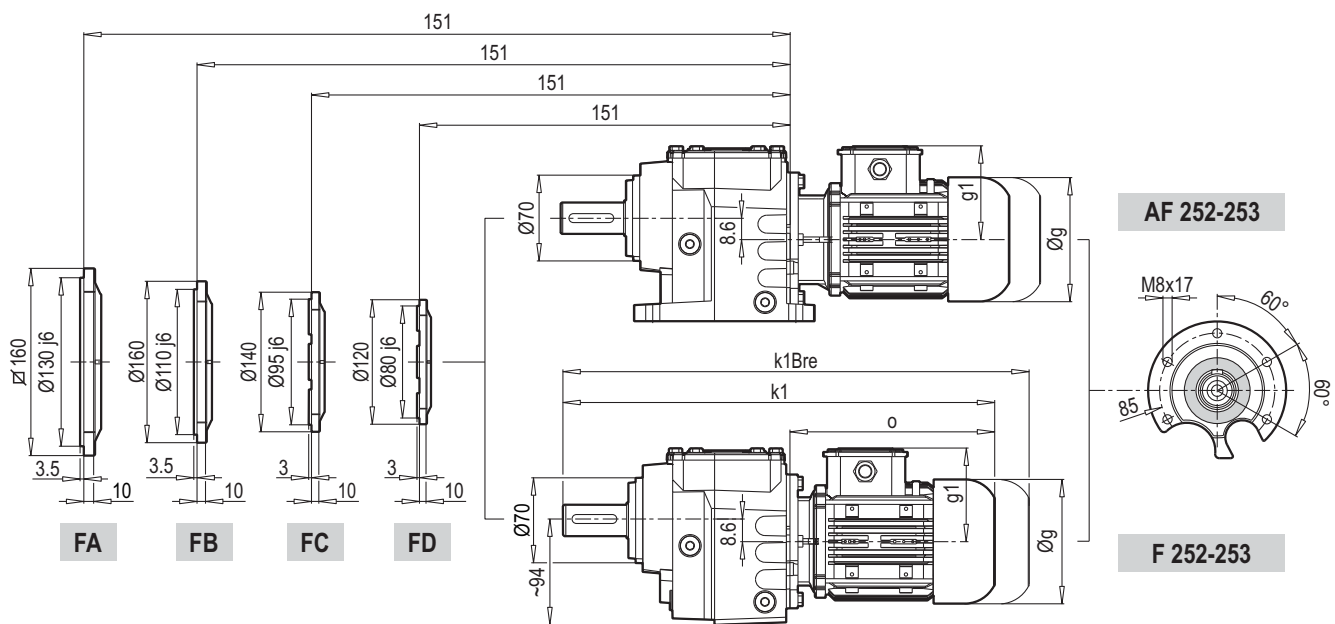
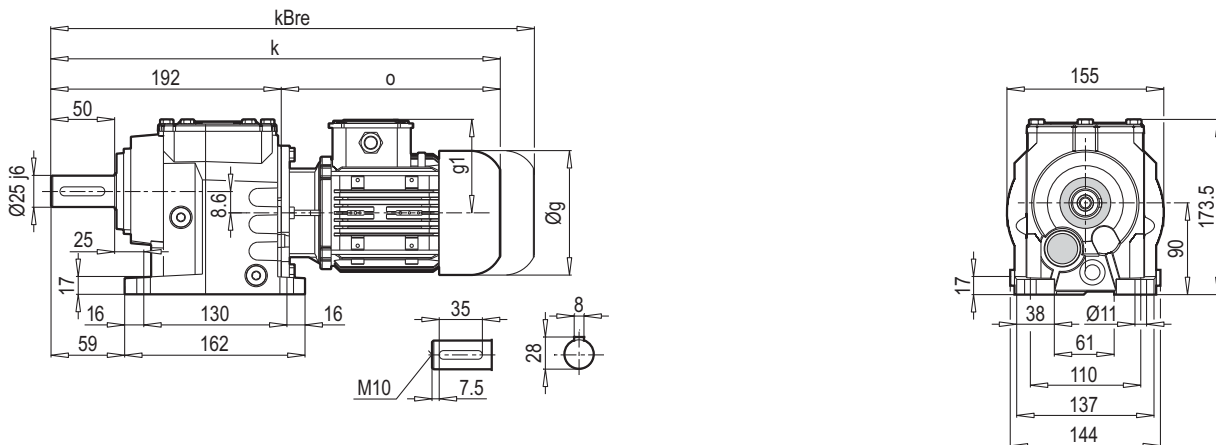

	63 M	71 M	80 M	90 S	90 L	100 L	112 M
g	124	140	159	193	193	217	232
g1	111	119	127	151	151	160	168
k	404	433	459	505	525	526	585
kBre	456	493	521	578	598	607	665
o	212	241	267	313	333	334	393
k1	413	442	468	514	534	535	594
k1Bre	465	502	590	587	607	616	674

A 252-253 PAM B5/B14

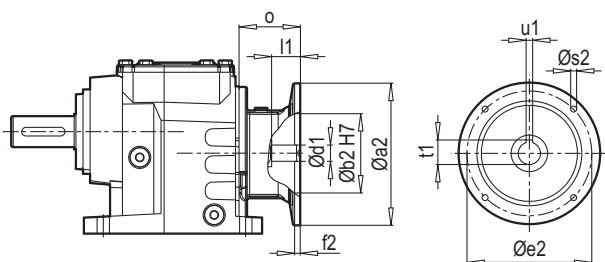

A 252-253 W

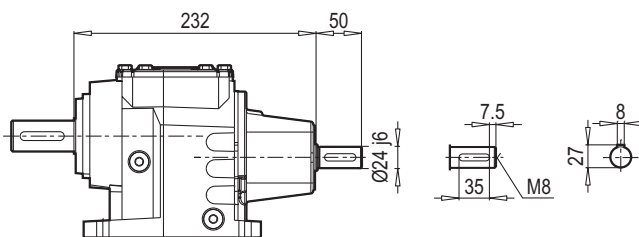

F 252-253 PAM B5/B14

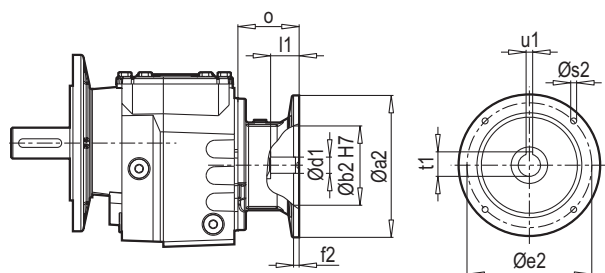

F 252-253 W

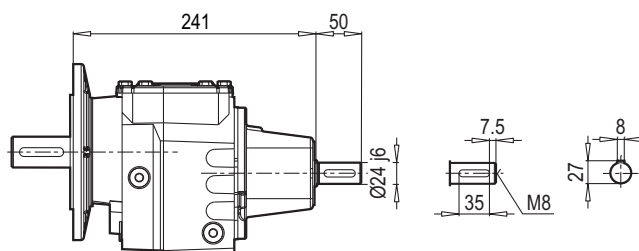

AF 252-253 PAM B5/B14

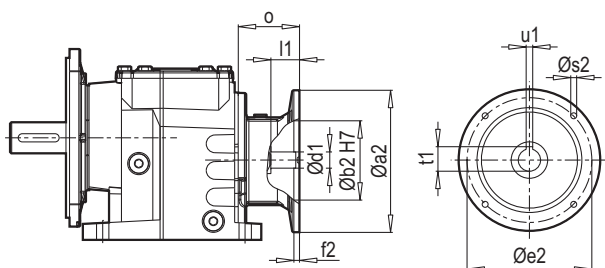

AF 252-253 W

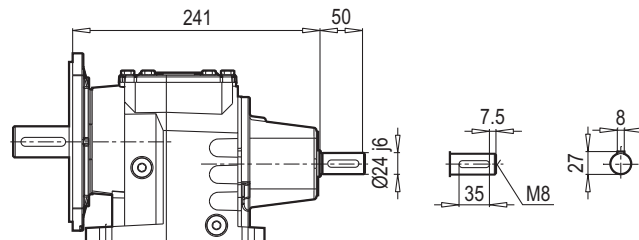

W ~ Kg	
A/F 252 - 253	14

Typ / Type / Tipo Type / Tipo	PAM B5	Øa2	Øb2	Øe2	f2	Øs2	Ød1	l1	t1	u1	o
A/F 252 A/F 253	63	140	95	115	4.5	M8	11	25	12.8	4	57
	71	160	110	130	5	M8	14	32	16.3	5	69
	80	200	130	165	5	M10	19	42	21.8	6	90
	90	200	130	165	5	M10	24	52	27.3	8	90
	100	250	180	215	5.5	M12	28	62	31.3	8	105
	112	250	180	215	5.5	M12	28	62	31.3	8	105

~ Kg	
PAM B5	A/F 252 - 253
63	12
71	13
80	14
90	14
100	18
112	18

Typ / Type / Tipo Type / Tipo	PAM B14	Øa2	Øb2	Øe2	f2	Øs2	Ød1	l1	t1	u1	o
A/F 252 A/F 253	63	90	60	75	2.5	6	11	25	12.8	4	57
	71	105	70	85	2.5	7	14	32	16.3	5	69
	80	120	80	100	3	7	19	42	21.8	6	90
	90	140	95	115	3	9	24	52	27.3	8	90
	100	160	110	130	3.5	9	28	62	31.3	8	105
	112	160	110	130	3.5	9	28	62	31.3	8	105

~ Kg	
PAM B14	A/F 252 - 253
63	11
71	12
80	13
90	13
100	14
112	14

A 301

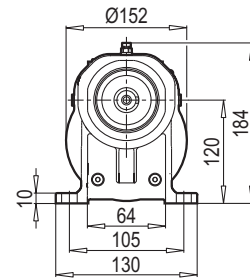
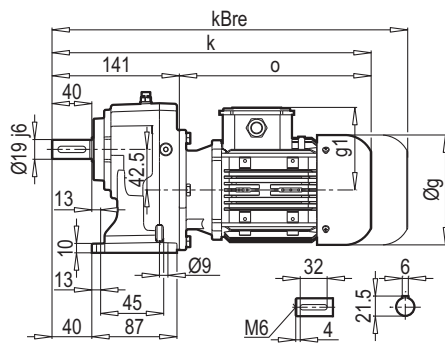

AF-M 301

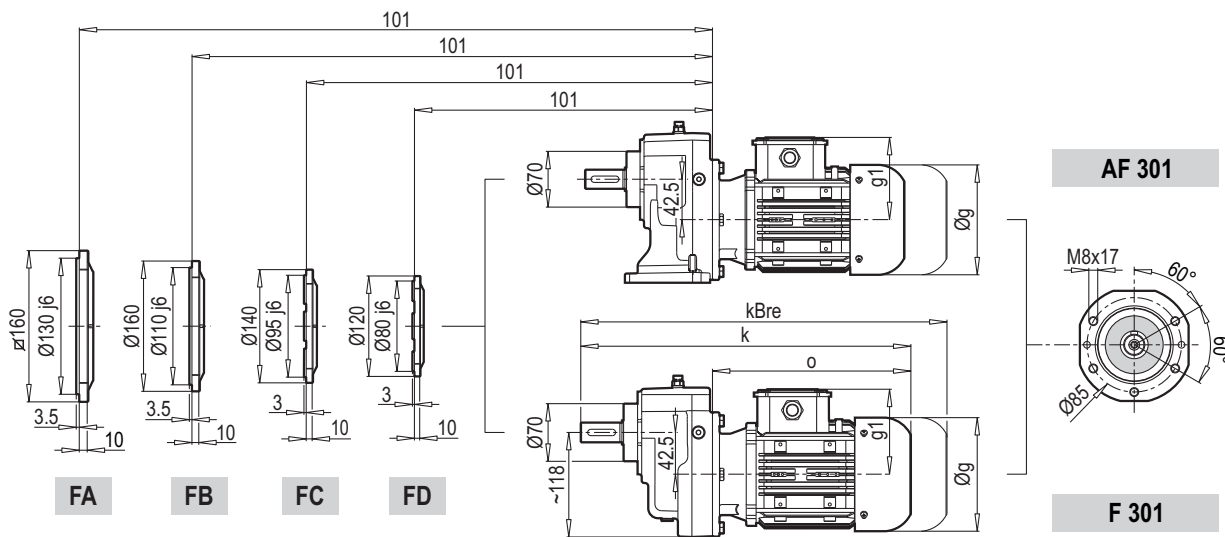
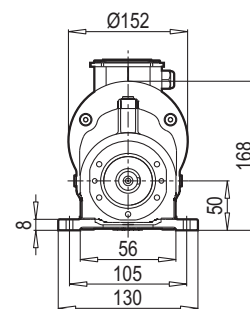
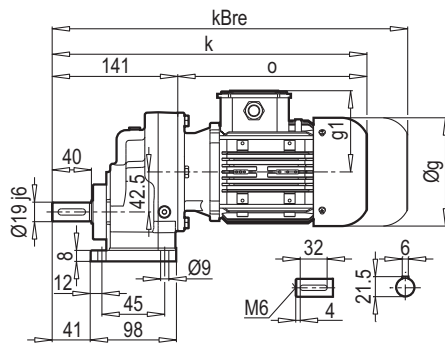

AF 301

F 301

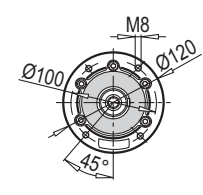
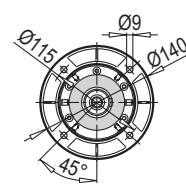
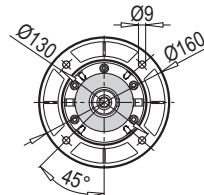
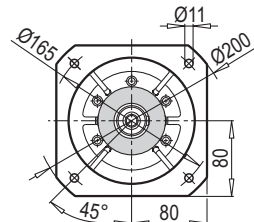
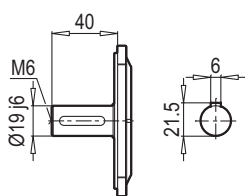

FA

FB

FC

FD

	71 M	80 M	90 S	90 L				
g	140	159	193	193				
g1	119	127	151	151				
k	382	408	454	474				
kBre	442	470	527	547				
o	241	267	313	333				

A 301 PAM B5/B14

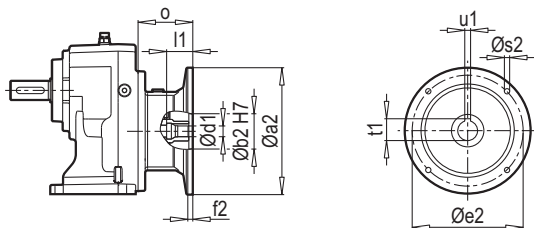

A 301 W

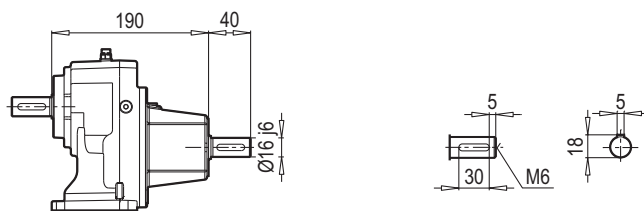

F 301 PAM B5/B14

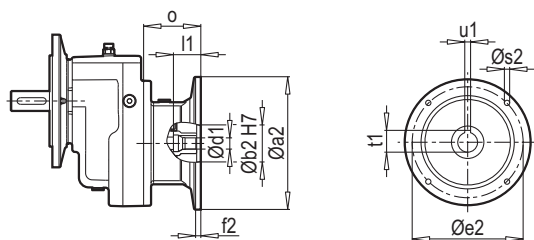

F 301 W

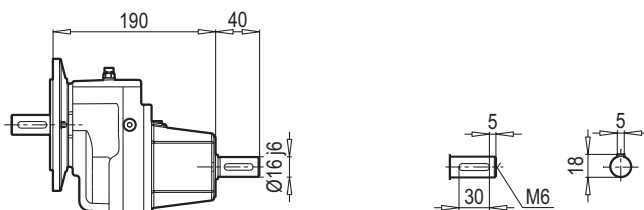

AF 301 PAM B5/B14

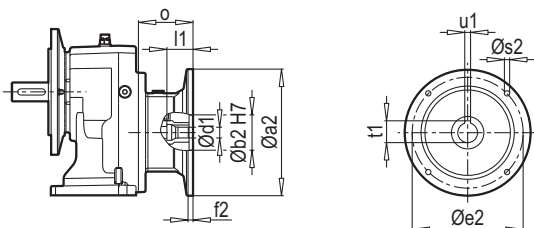

AF 301 W

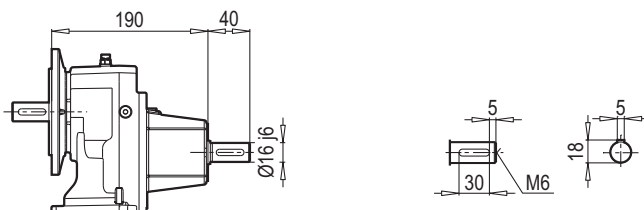

W ~ Kg	
A/F 301	10

AF-M 301 PAM B5/B14

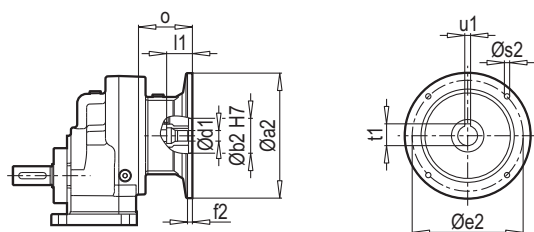

AF-M 301 W

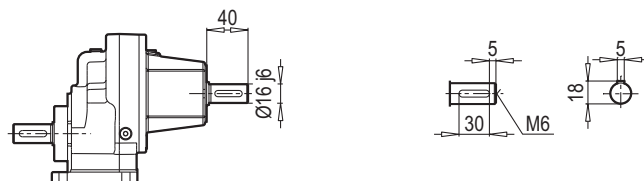

Typ / Type / Tipo Type / Tipo	PAM B5	Øa2	Øb2	Øe2	f2	Øs2	Ød1	l1	t1	u1	o
A/F 301	71	160	110	130	5	M8	14	32	16.3	5	69
	80	200	130	165	5	M10	19	42	21.8	6	90
	90	200	130	165	5	M10	24	52	27.3	8	90

~ Kg	
PAM B5	A/F 301
71	6
80	6.5
90	6.5

Typ / Type / Tipo Type / Tipo	PAM B14	Øa2	Øb2	Øe2	f2	Øs2	Ød1	l1	t1	u1	o
A/F 301	63	90	60	75	2.5	6	11	32	16.3	5	69
	71	105	70	85	2.5	7	14	42	21.8	6	90
	80	120	80	100	3	7	19	52	27.3	8	90

~ Kg	
PAM B14	A/F 301
63	5
71	5.5
80	5.5

A 302-303

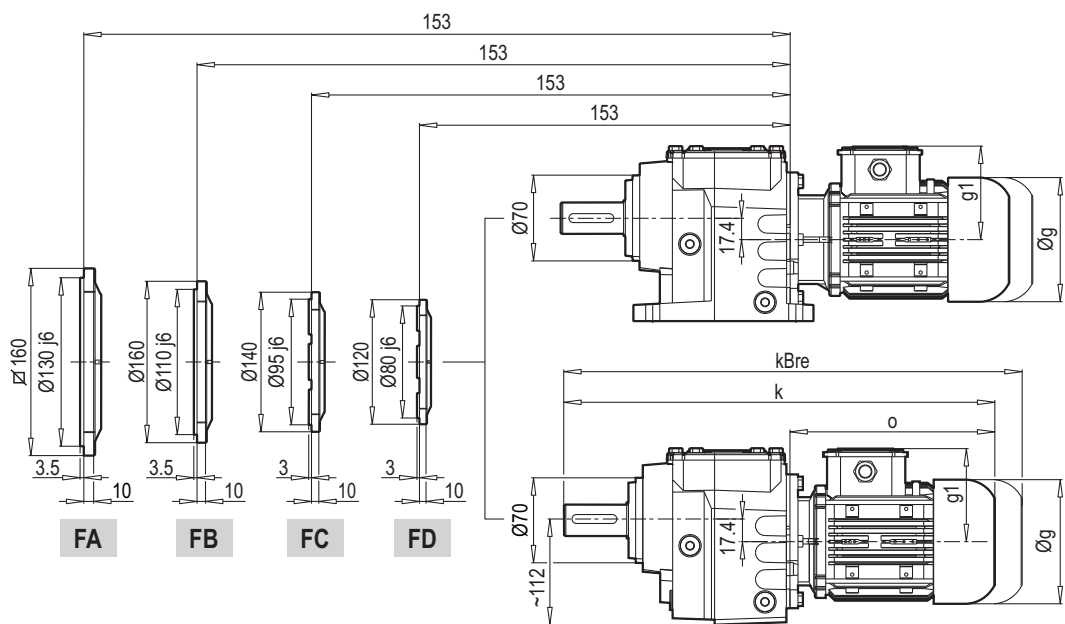
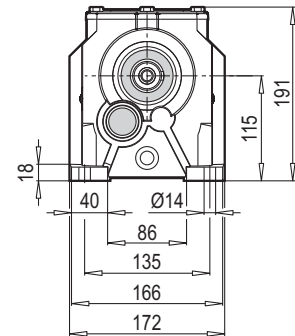
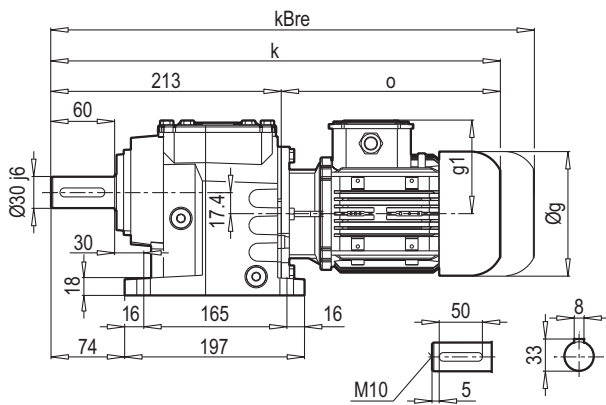

AF 302-303

F 302-303

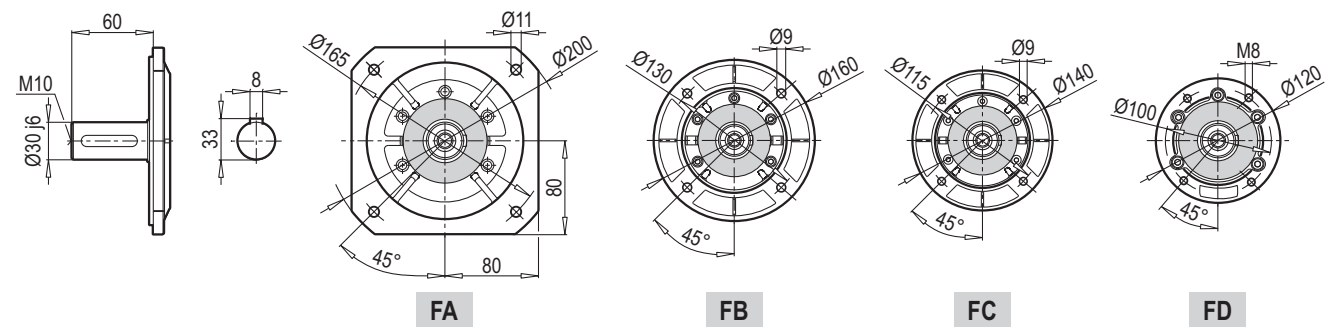

	63 M	71 M	80 M	90 S	90 L	100 L	112 M	
g	124	140	159	193	193	217	232	
g1	111	119	127	151	151	160	168	
k	425	454	480	526	546	547	606	
kBre	477	514	542	599	619	628	686	
o	212	241	267	313	333	334	393	

A 302-303 PAM B5/B14

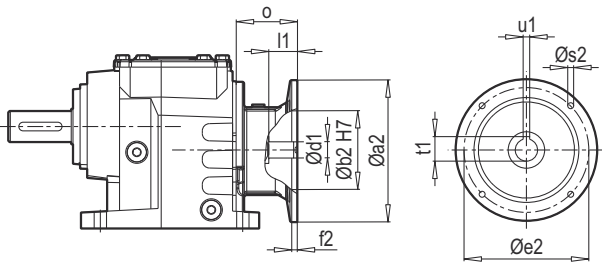

A 302-303 W

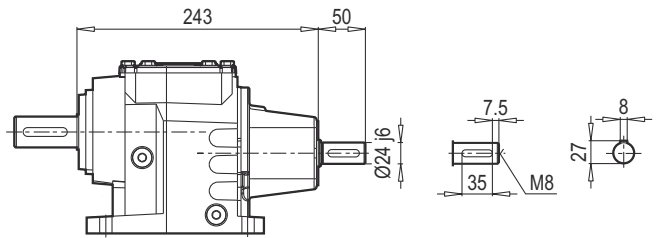

F 302-303 PAM B5/B14

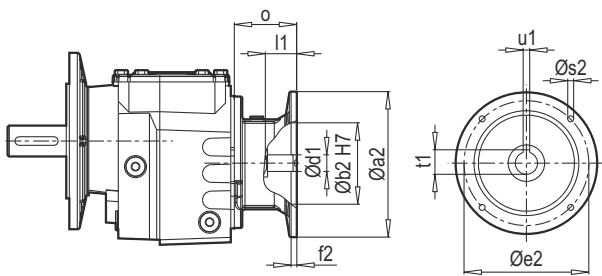

F 302-303 W

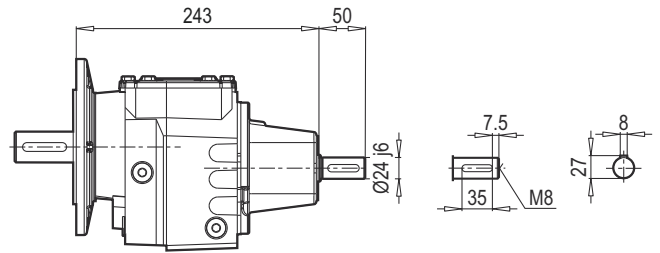

AF 302-303 PAM B5/B14

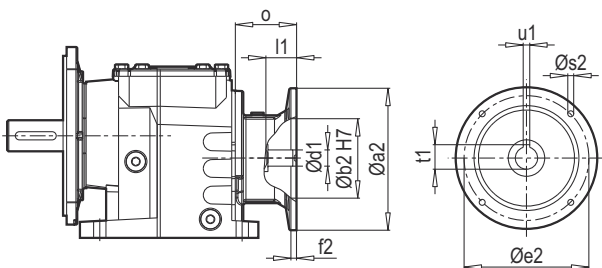

AF 302-303 W

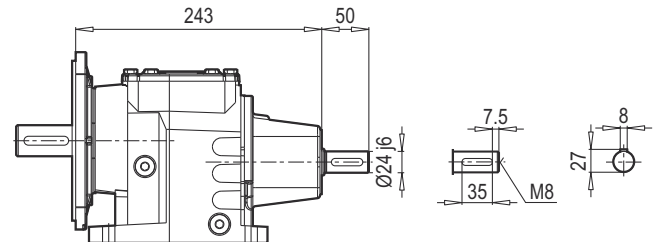

W ~ Kg	
A/F 302-303	17

Typ / Type / Tipo Type / Tipo	PAM B5	Øa2	Øb2	Øe2	f2	Øs2	Ød1	l1	t1	u1	o
A/F 302 A/F 303	63	140	95	115	4.5	M8	11	25	12.8	4	57
	71	160	110	130	5	M8	14	32	16.3	5	69
	80	200	130	165	5	M10	19	42	21.8	6	90
	90	200	130	165	5	M10	24	52	27.3	8	90
	100	250	180	215	5.5	M12	28	62	31.3	8	105
	112	250	180	215	5.5	M12	28	62	31.3	8	105

~ Kg	
PAM B5	A/F 302-303
63	15
71	16
80	17
90	17
100	21
112	21

Typ / Type / Tipo Type / Tipo	PAM B14	Øa2	Øb2	Øe2	f2	Øs2	Ød1	l1	t1	u1	o
A/F 302 A/F 303	63	90	60	75	2.5	6	11	25	12.8	4	57
	71	105	70	85	2.5	7	14	32	16.3	5	69
	80	120	80	100	3	7	19	42	21.8	6	90
	90	140	95	115	3	9	24	52	27.3	8	90
	100	160	110	130	3.5	9	28	62	31.3	8	105
	112	160	110	130	3.5	9	28	62	31.3	8	105

~ Kg	
PAM B14	A/F 302-303
63	14
71	15
80	16
90	16
100	17
112	17

A 351

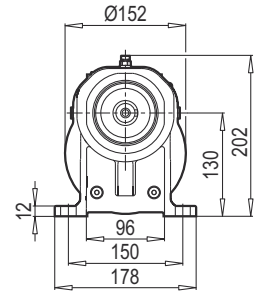
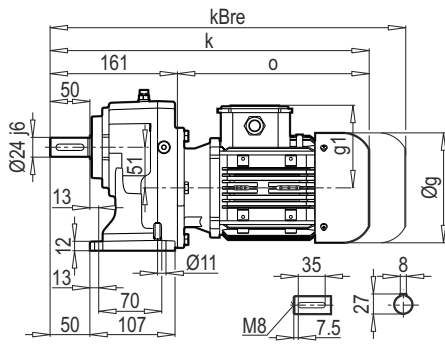

AF-M 351

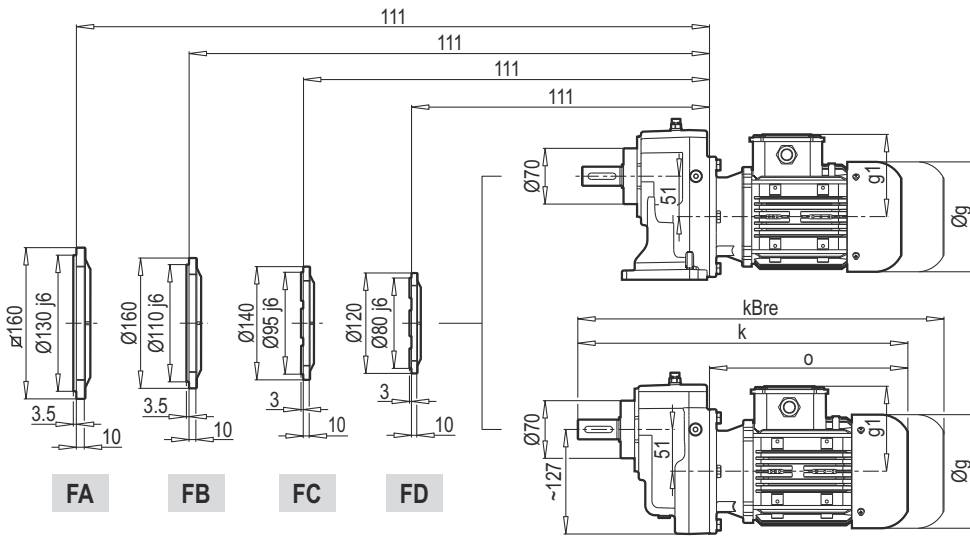
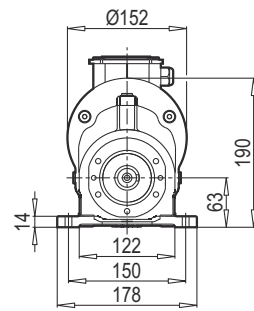
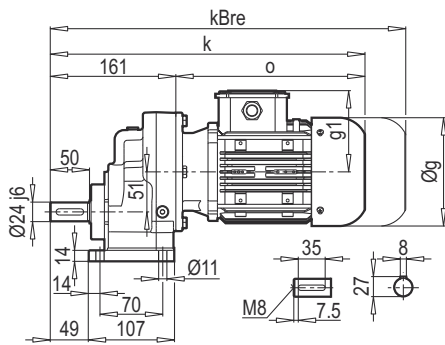

AF 351

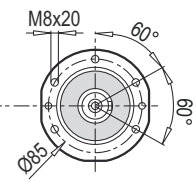

F 351

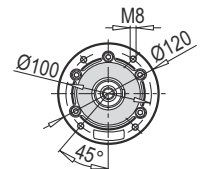
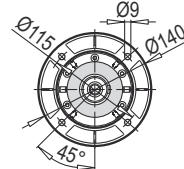
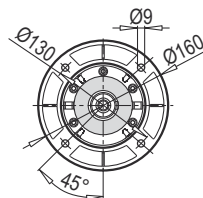
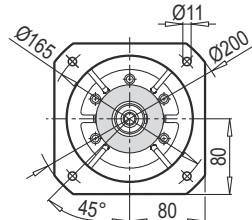
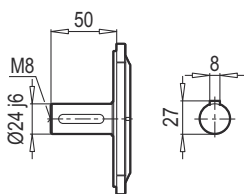

FA

FB

FC

FD

	71 M	80 M	90 S	90 L	100 L	112 M		
g	140	159	193	193	217	232		
g1	119	127	151	151	160	168		
k	402	428	474	494	495	554		
kBre	462	490	547	567	576	634		
o	241	267	313	333	334	393		

A 351 PAM B5/B14

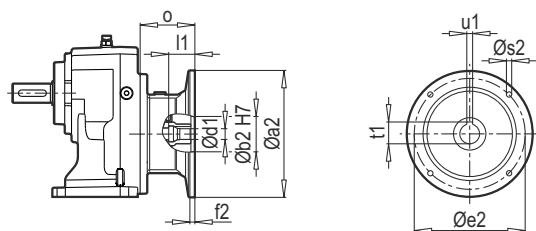

A 351 W

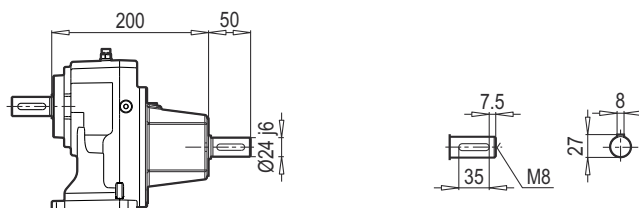

F 351 PAM B5/B14

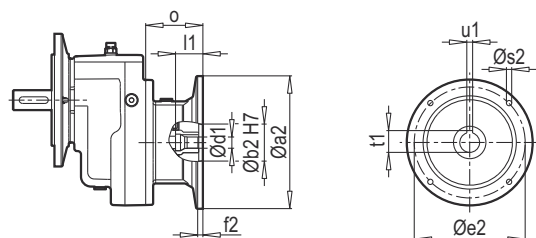

F 351 W

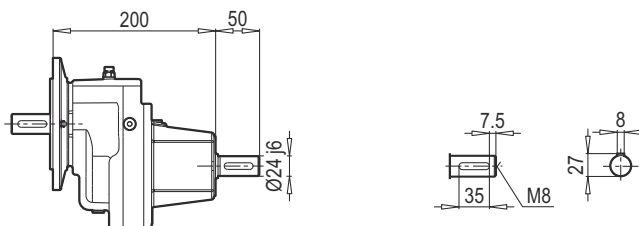

AF 351 PAM B5/B14

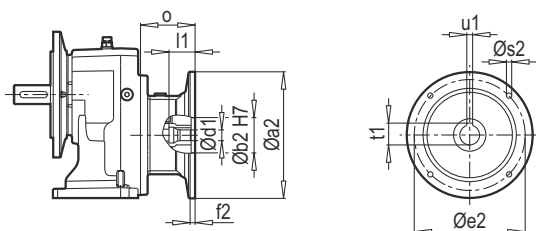

AF 351 W

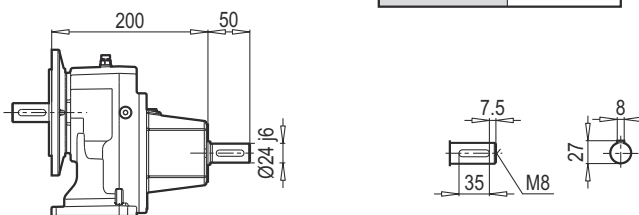

AF-M 351 PAM B5/B14

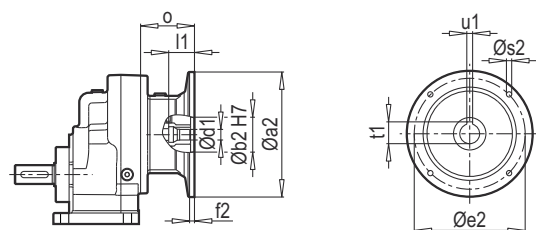

AF-M 351 W

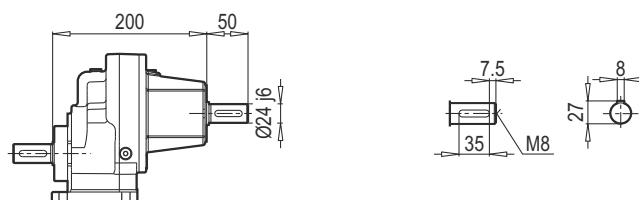

W ~ Kg	
A/F 351	12

Typ / Type / Tipo Type / Tipo	PAM B5	Øa2	Øb2	Øe2	f2	Øs2	Ød1	l1	t1	u1	o
A/F 351	71	160	110	130	5	M8	14	32	16.3	5	69
	80	200	130	165	5	M10	19	42	21.8	6	90
	90	200	130	165	5	M10	24	52	27.3	8	90
	100	250	180	215	5.5	M12	28	62	31.3	8	105
	112	250	180	215	5.5	M12	28	62	31.3	8	105

~ Kg	
PAM B5	A/F 351
71	8
80	8.5
90	8.5
100	13
112	13

Typ / Type / Tipo Type / Tipo	PAM B14	Øa2	Øb2	Øe2	f2	Øs2	Ød1	l1	t1	u1	o
A/F 351	71	105	70	85	2.5	7	14	32	16.3	5	69
	80	120	80	100	3	7	19	42	21.8	6	90
	90	140	95	115	3	9	24	52	27.3	8	90
	100	160	110	130	3.5	9	28	62	31.3	8	105
	112	160	110	130	3.5	9	28	62	31.3	8	105

~ Kg	
PAM B14	A/F 351
71	7
80	7.5
90	7.5
100	9.5
112	9.5

A 352-353

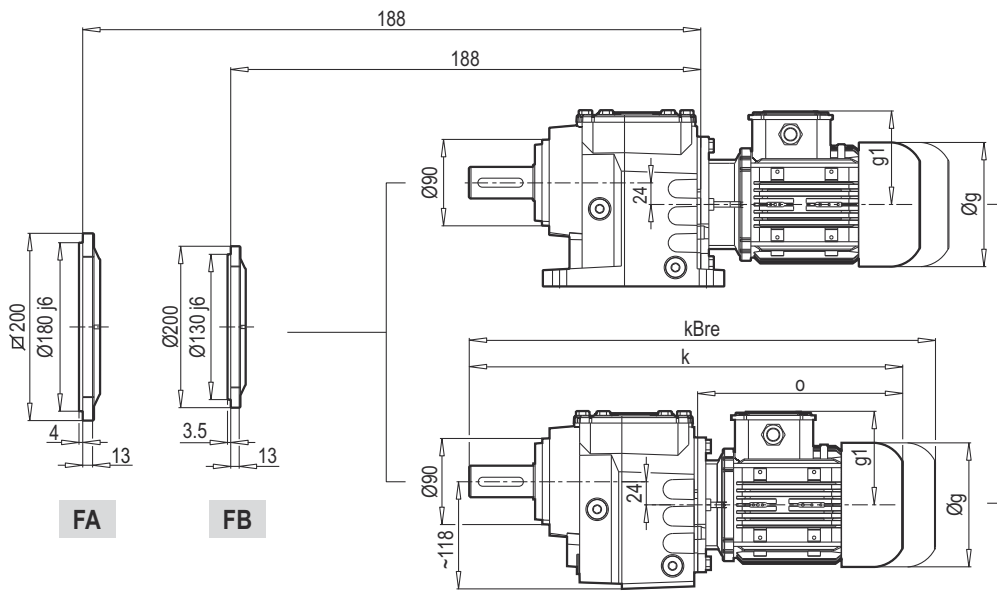
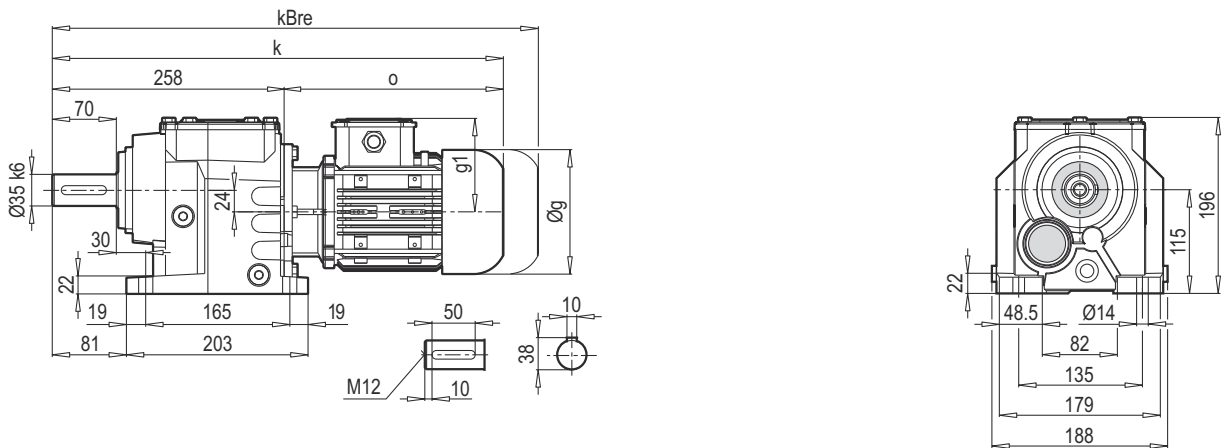

AF 352-353

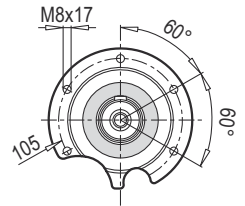

F 352-353

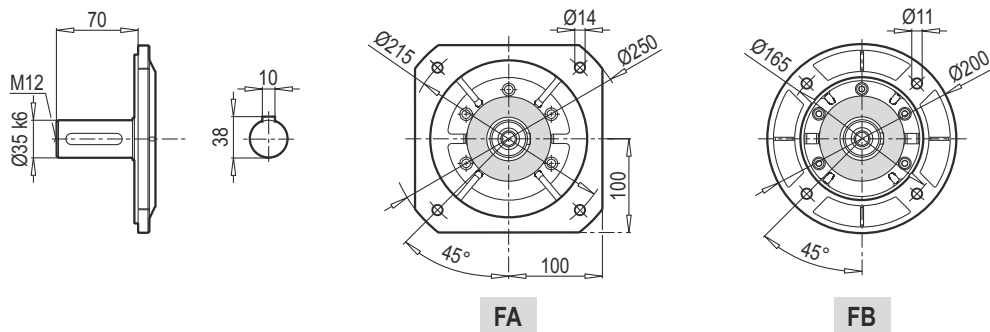

FA

FB

	63 M	71 M	80 M	90 S	90 L	100 L	112 M
g	124	140	159	193	193	217	232
g1	111	119	127	151	151	160	168
k	470	499	525	571	591	592	651
kBre	522	559	587	644	664	673	731
o	212	241	267	313	333	334	393

A 352-353 PAM B5/B14

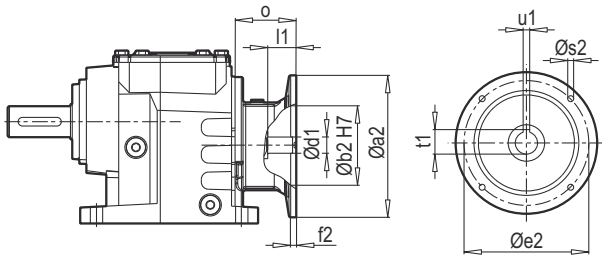

A 352-353 W

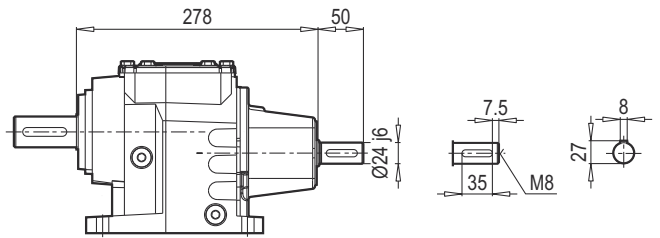

F 352-353 PAM B5/B14

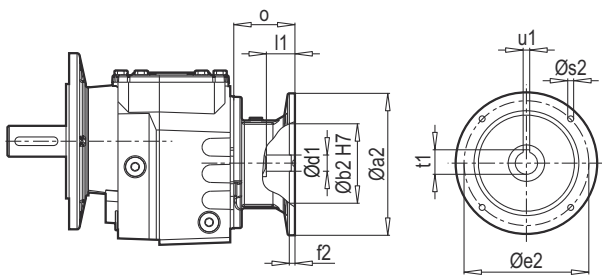

F 352-353 W

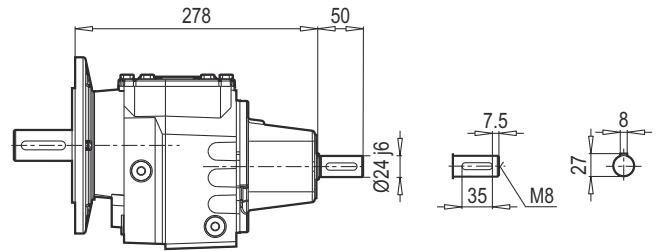

AF 352-353 PAM B5/B14

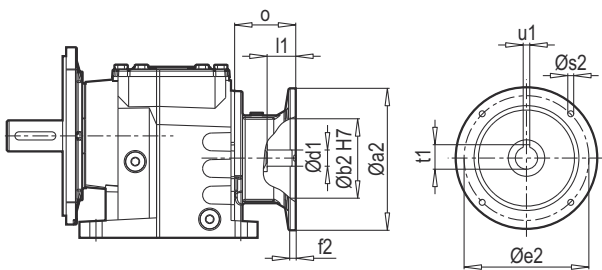

AF 352-353 W

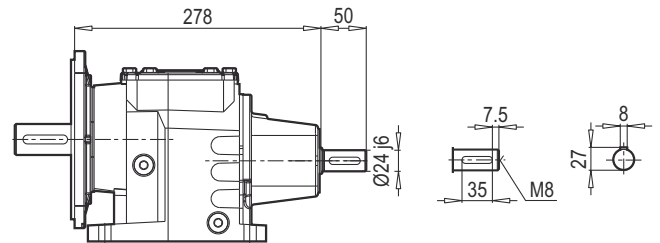

W ~ Kg	
A/F 352-353	22

Typ / Type / Tipo Type / Tipo	PAM B5	Øa2	Øb2	Øe2	f2	Øs2	Ød1	l1	t1	u1	o
71	160	110	130	5	M8	14	32	16.3	5	69	
80	200	130	165	5	M10	19	42	21.8	6	90	
90	200	130	165	5	M10	24	52	27.3	8	90	
100	250	180	215	5.5	M12	28	62	31.3	8	105	
112	250	180	215	5.5	M12	28	62	31.3	8	105	

~ Kg	
PAM B5	A/F 352-353
63	20
71	21
80	22
90	22
100	26
112	26

Typ / Type / Tipo Type / Tipo	PAM B14	Øa2	Øb2	Øe2	f2	Øs2	Ød1	l1	t1	u1	o
71	105	70	85	2.5	7	14	32	16.3	5	69	
80	120	80	100	3	7	19	42	21.8	6	90	
90	140	95	115	3	9	24	52	27.3	8	90	
100	160	110	130	3.5	9	28	62	31.3	8	105	
112	160	110	130	3.5	9	28	62	31.3	8	105	

~ Kg	
PAM B14	A/F 352-353
63	19
71	20
80	21
90	21
100	23
112	23

A 401

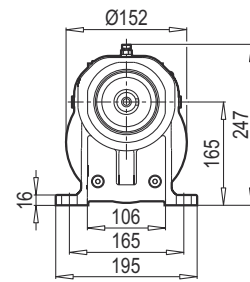
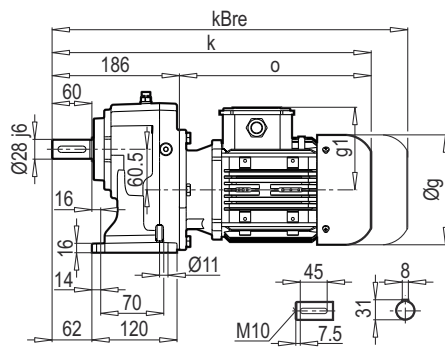

AF-M 401

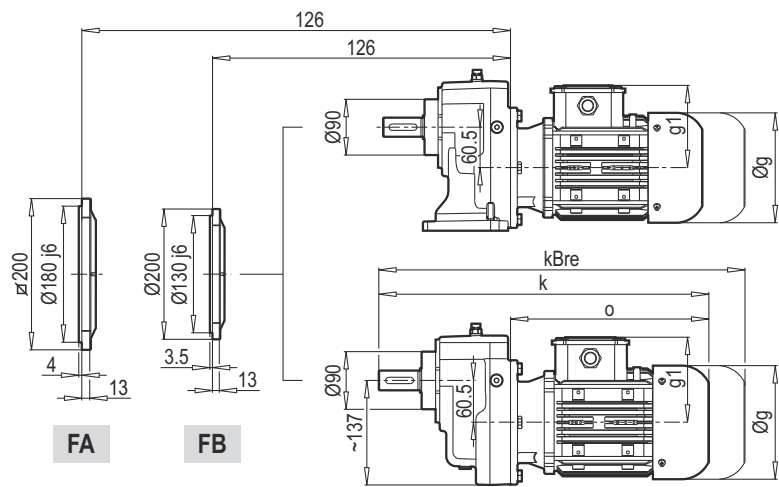
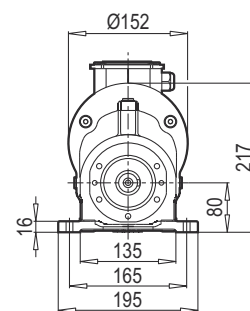
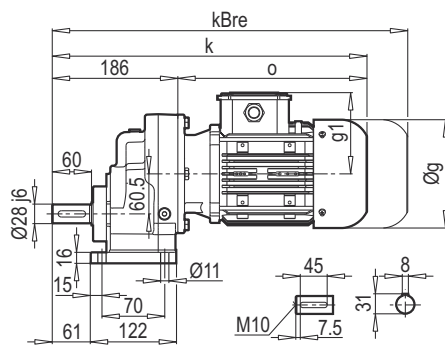

AF 401

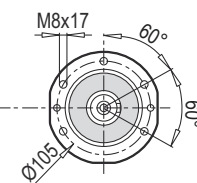

F 401

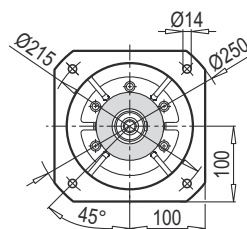
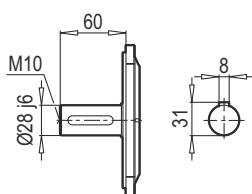

FA

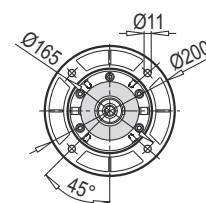

FB

	80 M	90 S	90 L	100 L	112 M			
g	159	193	193	217	232			
g1	127	151	151	160	168			
k	453	499	519	520	579			
kBre	515	572	592	601	659			
o	267	313	333	334	393			

A 401 PAM B5/B14

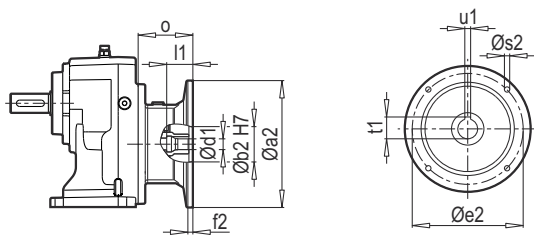

A 401 W

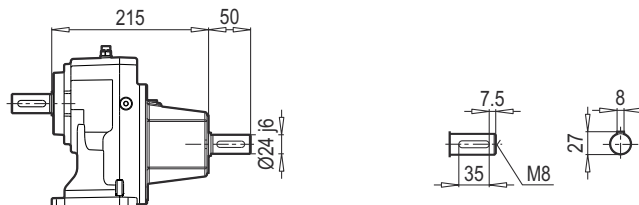

F 401 PAM B5/B14

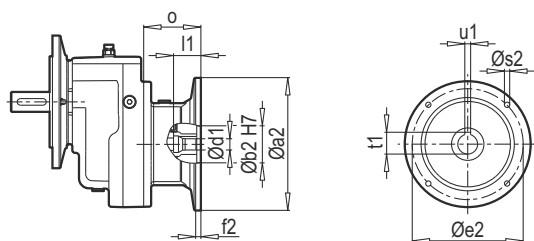

F 401 W

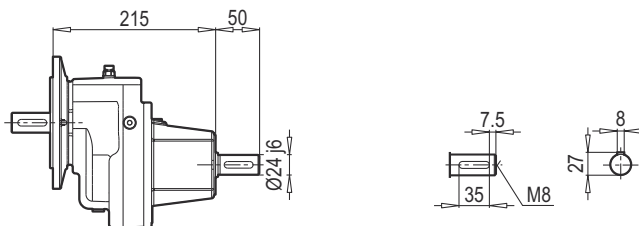

AF 401 PAM B5/B14

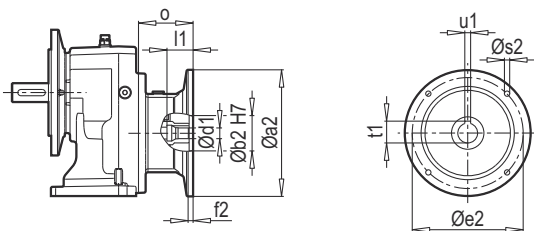

AF 401 W

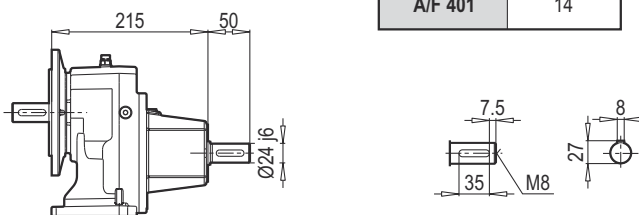

W ~ Kg	
A/F 401	14

AF-M 401 PAM B5/B14

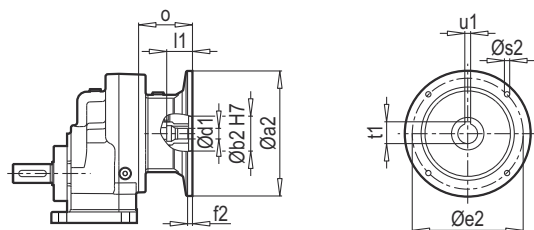

AF-M 401 W

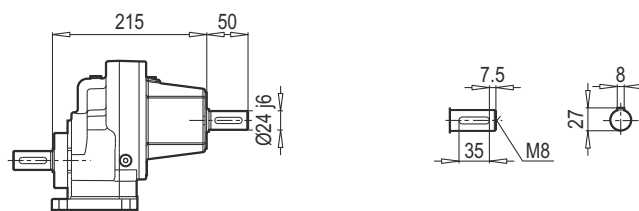

Typ / Type / Tipo Type / Tipo	PAM B5	Øa2	Øb2	Øe2	f2	Øs2	Ød1	l1	t1	u1	o
A/F 401	80	200	130	165	5	M10	19	42	21.8	6	90
	90	200	130	165	5	M10	24	52	27.3	8	90
	100	250	180	215	5.5	M12	28	62	31.3	8	105
	112	250	180	215	5.5	M12	28	62	31.3	8	105

~ Kg	
PAM B5	A/F 401
80	11
90	11
100	15.5
112	15.5

Typ / Type / Tipo Type / Tipo	PAM B14	Øa2	Øb2	Øe2	f2	Øs2	Ød1	l1	t1	u1	o
A/F 401	80	120	80	100	3	7	19	42	21.8	6	90
	90	140	95	115	3	9	24	52	27.3	8	90
	100	160	110	130	3.5	9	28	62	31.3	8	105
	112	160	110	130	3.5	9	28	62	31.3	8	105

~ Kg	
PAM B14	A/F 401
80	10
90	10
100	12
112	12

A 402-403

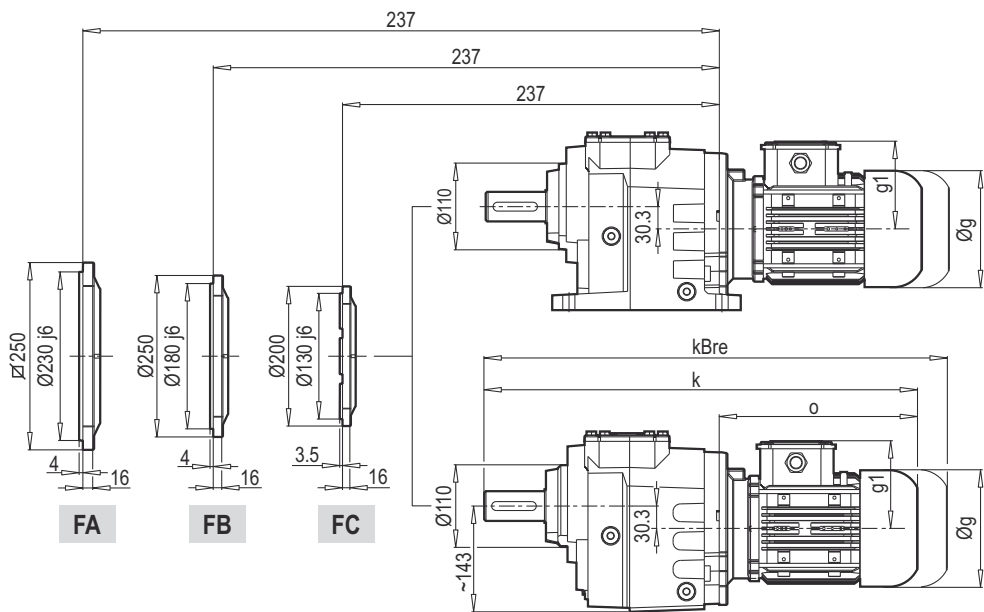
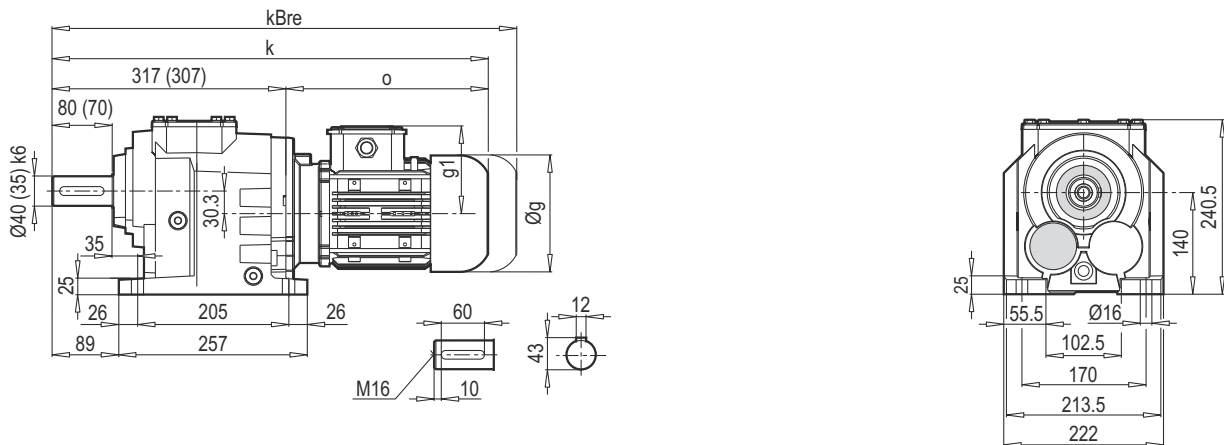

AF 402-403

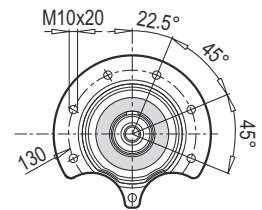

F 402-403

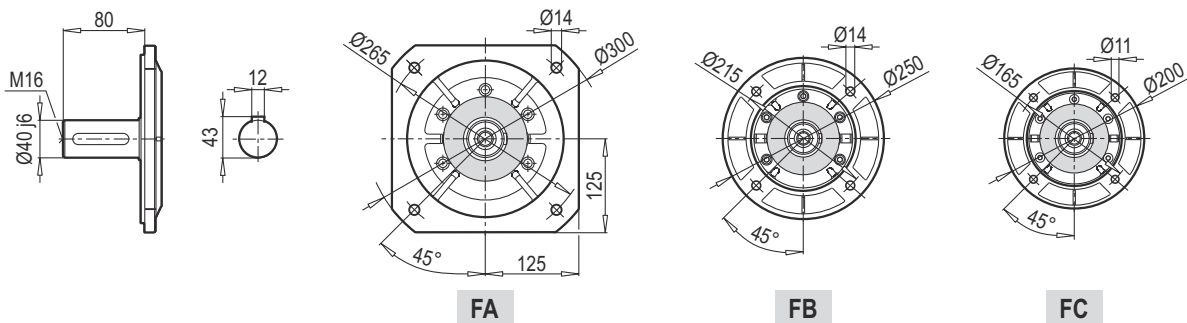

	71 M	80 M	90 S	90 L	100 L	112 M	132 S	132 M
g	140	159	193	193	217	232	279	279
g1	119	127	151	151	160	168	182	182
k	538 (528)	564 (554)	610 (600)	630 (620)	653 (643)	706 (696)	713 (703)	748 (738)
kBre	598 (588)	626 (616)	683 (673)	703 (693)	734 (724)	786 (776)	821 (811)	889 (879)
o	221	247	293	313	336	389	396	431

A 402-403 PAM B5/B14

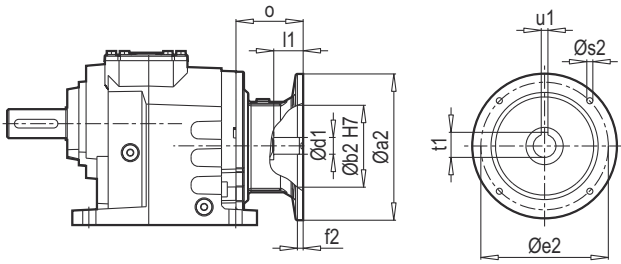

A 402-403 W

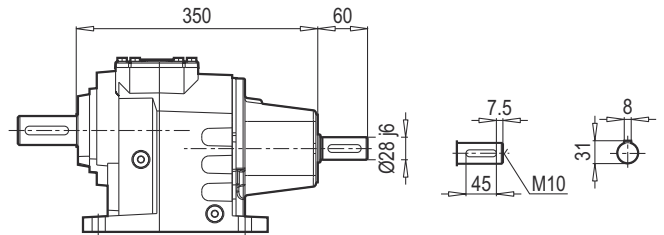

F 402-403 PAM B5/B14

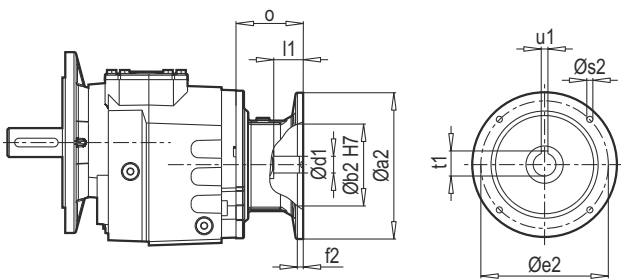

F 402-403 W

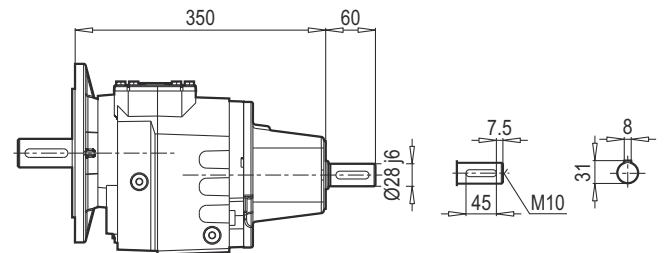

AF 402-403 PAM B5/B14

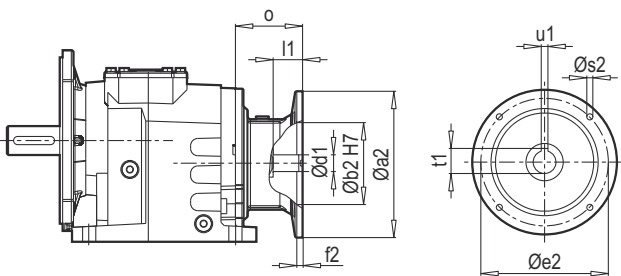

AF 402-403 W

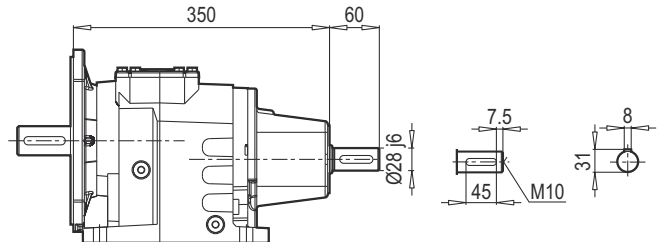

W ~ Kg	
A/F 402-403	37

Typ / Type / Tipo Type / Tipo	PAM B5	Øa2	Øb2	Øe2	f2	Øs2	Ød1	l1	t1	u1	o
A/F 402 A/F 403	71	160	110	130	5	M8	14	32	16.3	5	49
	80	200	130	165	5	M10	19	42	21.8	6	70
	90	200	130	165	5	M10	24	52	27.3	8	70
	100	250	180	215	5.5	M12	28	62	31.3	8	85
	112	250	180	215	5.5	M12	28	62	31.3	8	85
	132	300	230	265	5.5	M12	38	82	41.3	10	110

~ Kg	
PAM B5	A/F 402-403
71	32
80	35
90	35
100	37
112	37
132	41

Typ / Type / Tipo Type / Tipo	PAM B14	Øa2	Øb2	Øe2	f2	Øs2	Ød1	l1	t1	u1	o
A/F 402 A/F 403	71	105	70	85	2.5	7	14	32	16.3	5	49
	80	120	80	100	3	7	19	42	21.8	6	70
	90	140	95	115	3	9	24	52	27.3	8	70
	100	160	110	130	3.5	9	28	62	31.3	8	85
	112	160	110	130	3.5	9	28	62	31.3	8	85
	132	200	130	165	3.5	11	38	82	41.3	10	110

~ Kg	
PAM B14	A/F 402-403
71	30
80	31
90	31
100	32
112	32
132	38

A 501

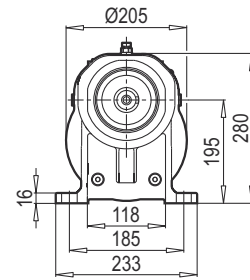
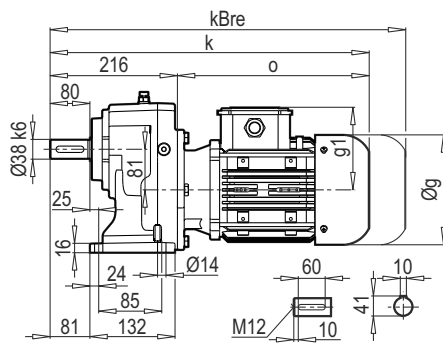

AF-M 501

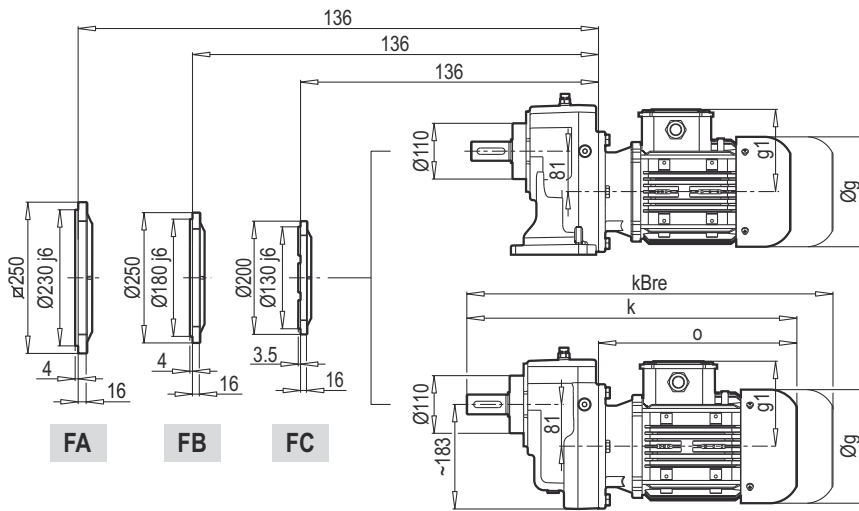
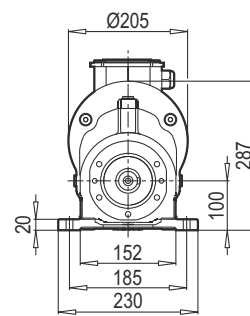
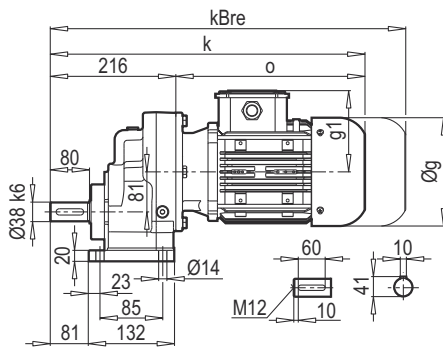

AF 501

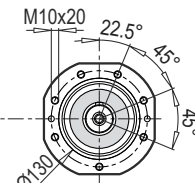

F 501

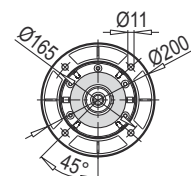
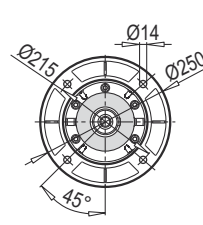
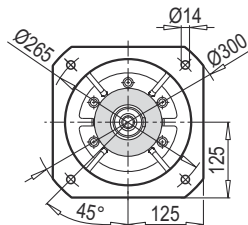
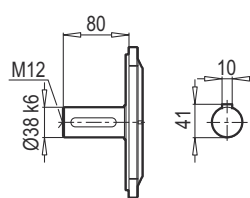

FA

FB

FC

	80 M	90 S	90 L	100 L	112 M	132 S	132 M	
g	159	193	193	217	232	279	279	
g1	127	151	151	160	168	182	182	
k	463	509	529	552	605	612	647	
kBre	525	582	602	633	685	720	788	
o	247	293	313	336	389	396	431	

A 501 PAM B5/B14

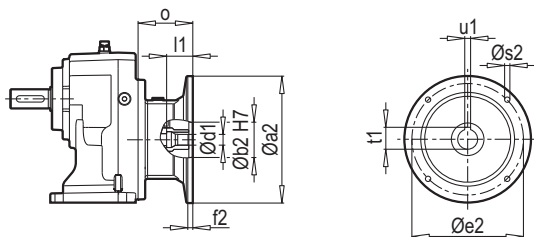

A 501 W

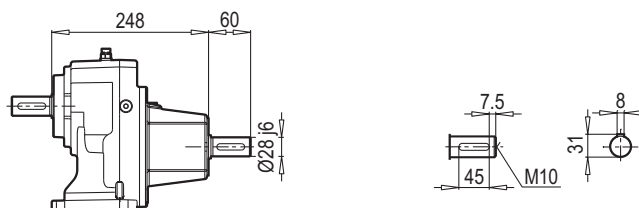

F 501 PAM B5/B14

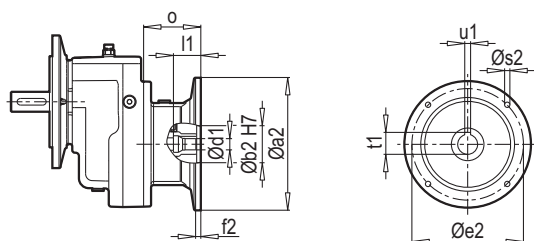

F 501 W

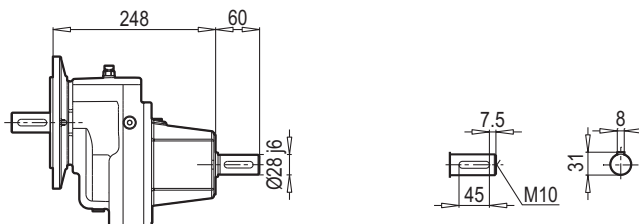

AF 501 PAM B5/B14

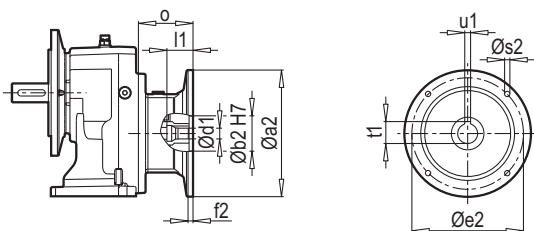

AF 501 W

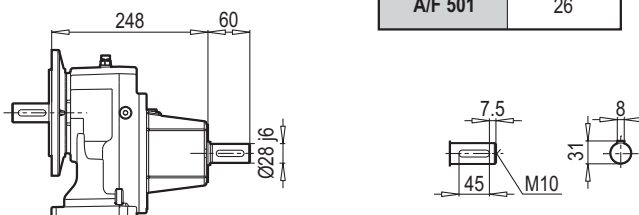

W ~ Kg	
A/F 501	26

AF-M 501 PAM B5/B14

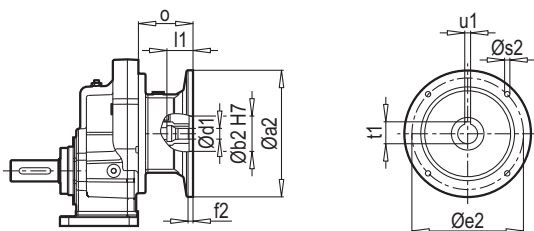

AF-M 501 W

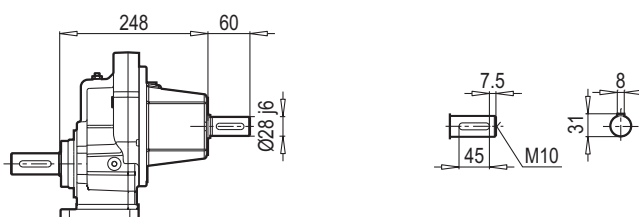

Typ / Type / Tipo Type / Tipo	PAM B5	Øa2	Øb2	Øe2	f2	Øs2	Ød1	l1	t1	u1	o
A/F 501	80	200	130	165	5	M10	19	42	21.8	6	70
	90	200	130	165	5	M10	24	52	27.3	8	70
	100	250	180	215	5.5	M12	28	62	31.3	8	85
	112	250	180	215	5.5	M12	28	62	31.3	8	85
	132	300	230	265	5.5	M12	38	82	41.3	10	110

~ Kg	
PAM B5	A/F 501
80	22
90	22
100	25
112	25
132	27

Typ / Type / Tipo Type / Tipo	PAM B14	Øa2	Øb2	Øe2	f2	Øs2	Ød1	l1	t1	u1	o
A/F 501	80	120	80	100	3	7	19	42	21.8	6	70
	90	140	95	115	3	9	24	52	27.3	8	70
	100	160	110	130	3.5	9	28	62	31.3	8	85
	112	160	110	130	3.5	9	28	62	31.3	8	85
	132	200	130	165	3.5	11	38	82	41.3	10	110

~ Kg	
PAM B14	A/F 501
80	18.5
90	18.5
100	21
112	21
132	24

A 502-503

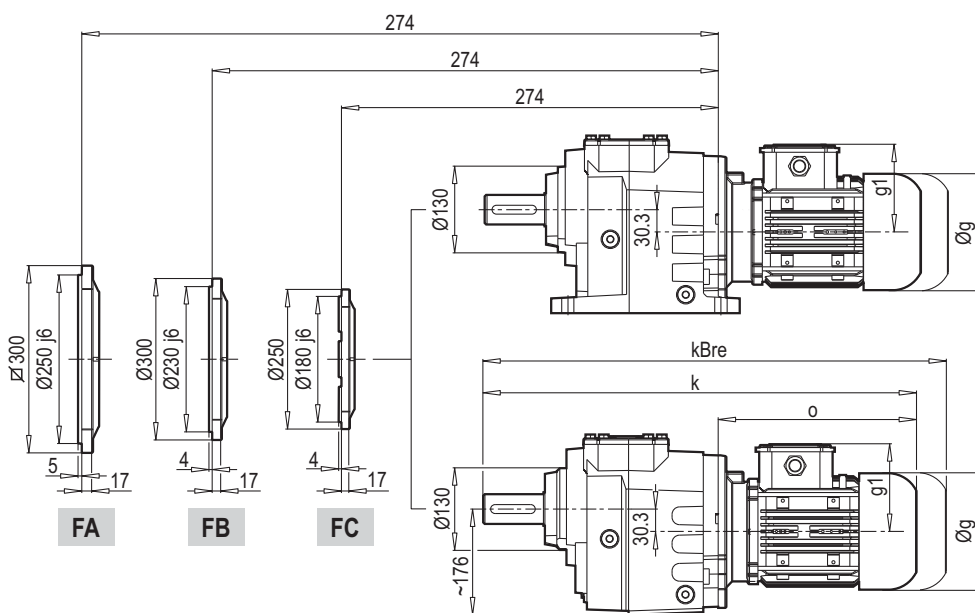
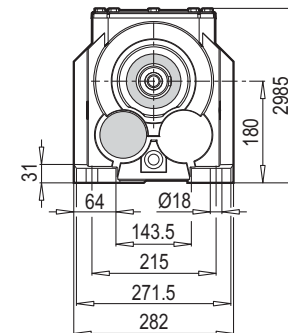
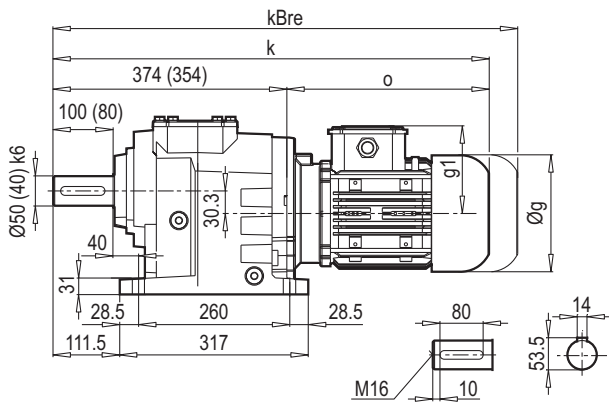

AF 502-503

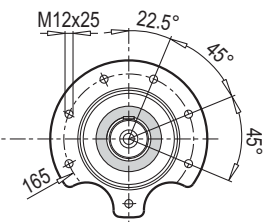

F 502-503

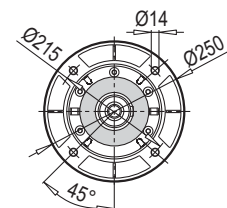
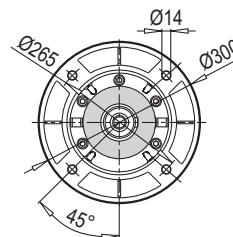
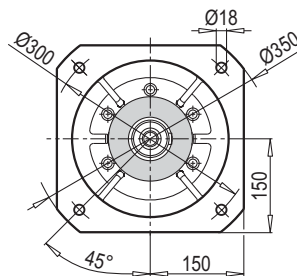
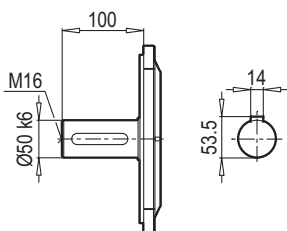

FA

FB

FC

	80 M	90 S	90 L	100 L	112 M	132 S	132 M	160 M/L
g	159	193	193	217	232	279	279	323
g1	127	151	151	160	168	182	182	200
k	621 (601)	667 (647)	687 (667)	710 (690)	763 (743)	770 (750)	805 (785)	892 (872)
kBre	683 (663)	740 (720)	760 (740)	791 (771)	843 (823)	878 (858)	946 (926)	1044 (1024)
o	247	293	313	336	389	396	431	518

A 502-503 PAM B5/B14

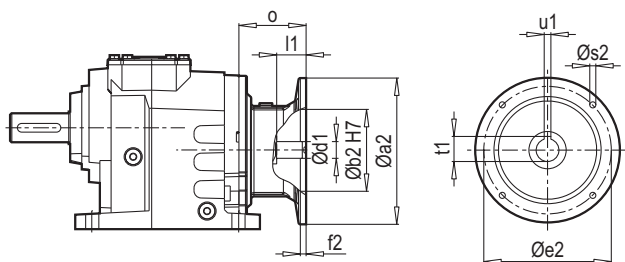

A 502-503 W

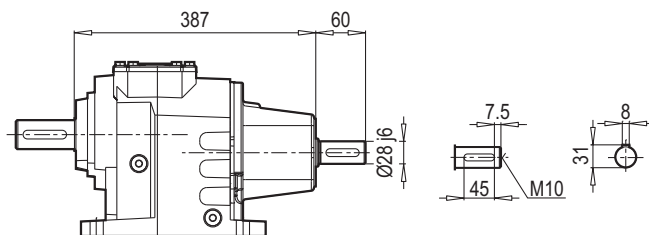

F 502-503 PAM B5/B14

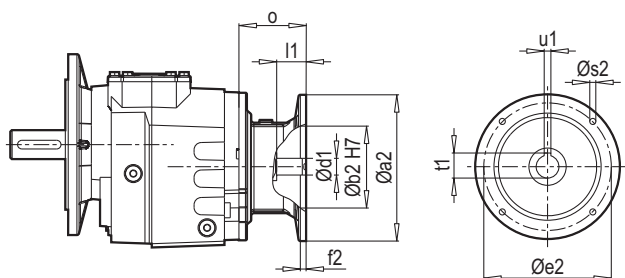

F 502-503 W

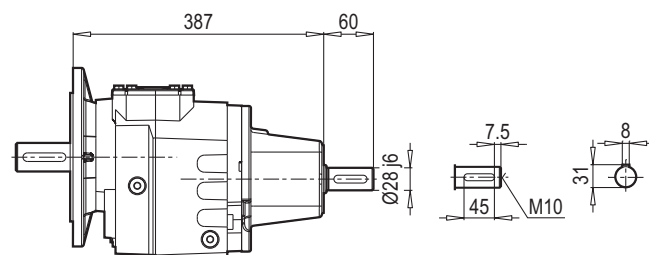

AF 502-503 PAM B5/B14

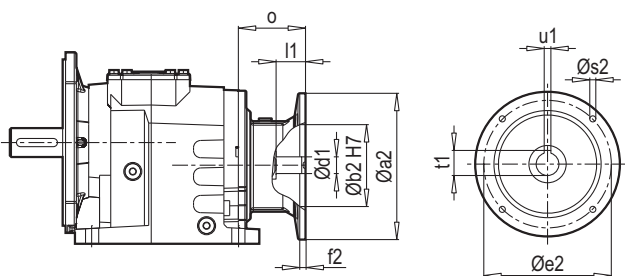

AF 502-503 W

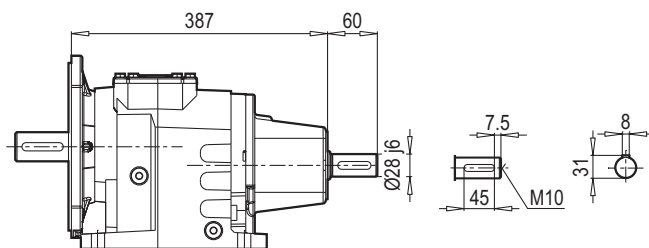

W ~ Kg	
A/F 502-503	54

Typ / Type / Tipo Type / Tipo	PAM B5	Øa2	Øb2	Øe2	f2	Øs2	Ød1	l1	t1	u1	o
	90	200	130	165	5	M10	24	52	27.3	8	70
	100	250	180	215	5.5	M12	28	62	31.3	8	85
	112	250	180	215	5.5	M12	28	62	31.3	8	85
	132	300	230	265	5.5	M12	38	82	41.3	10	110
	160	350	250	300	7	M16	42	112	45.3	12	158

~ Kg	
PAM B5	A/F 502-503
80	52
90	52
100	54
112	54
132	58
160	65

Typ / Type / Tipo Type / Tipo	PAM B14	Øa2	Øb2	Øe2	f2	Øs2	Ød1	l1	t1	u1	o
	90	140	95	115	3	9	24	52	27.3	8	70
	100	160	110	130	3.5	9	28	62	31.3	8	85
	112	160	110	130	3.5	9	28	62	31.3	8	85
	132	200	130	165	3.5	11	38	82	41.3	10	110

~ Kg	
PAM B14	A/F 502-503
80	48
90	48
100	50
112	50
132	55

A 601

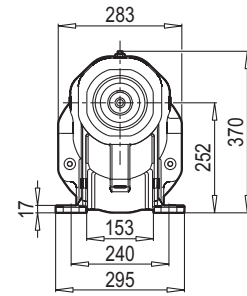
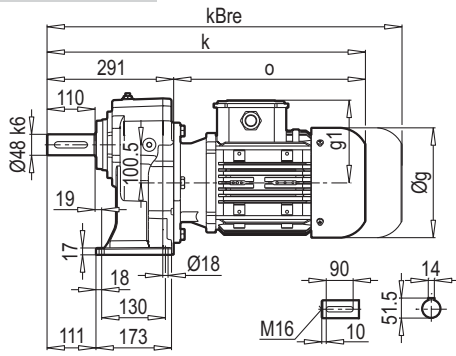

AF-M 601

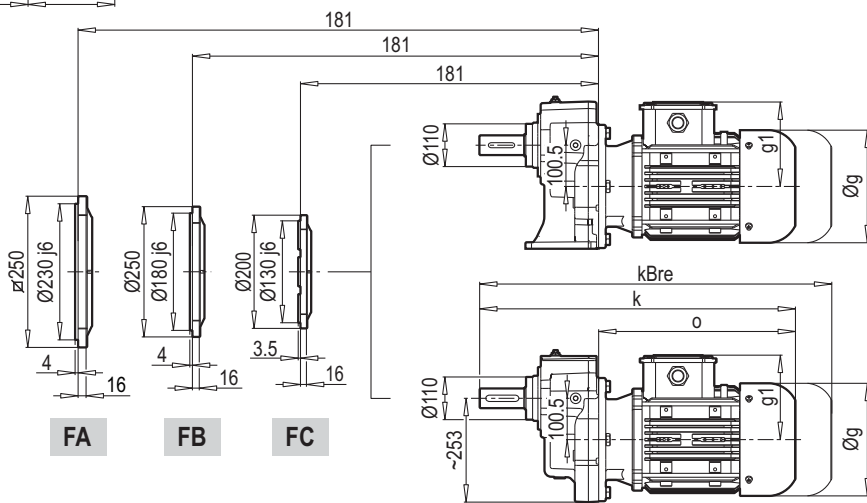
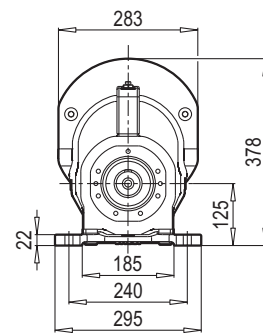
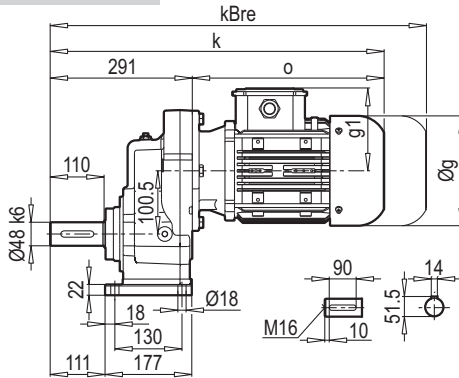

AF 601

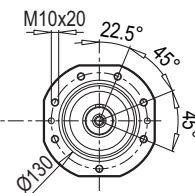

F 601

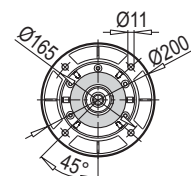
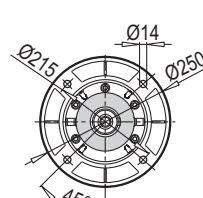
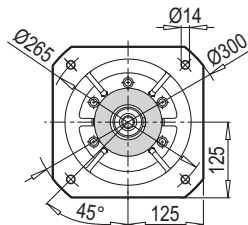
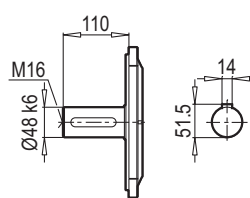

FA

FB

FC

	100 L	112 M	132 S	132 M	160 M/L	180 M/L		
g	217	232	279	279	323	370		
g1	160	168	182	182	200	248		
k	617	671	677	712	799	864		
kBre	698	751	785	853	951	1026		
o	326	380	386	421	508	573		

A 601 PAM B5/B14

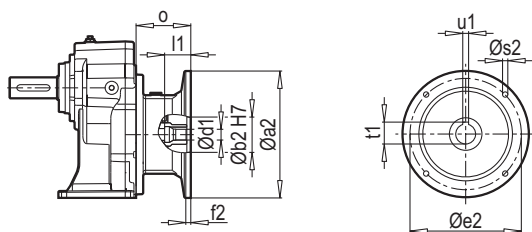

A 601 W

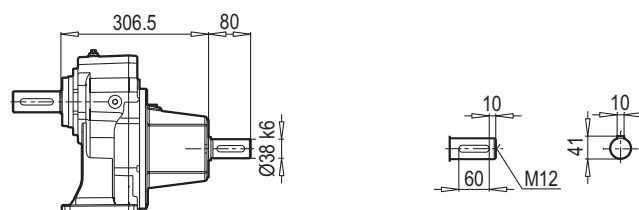

F 601 PAM B5/B14

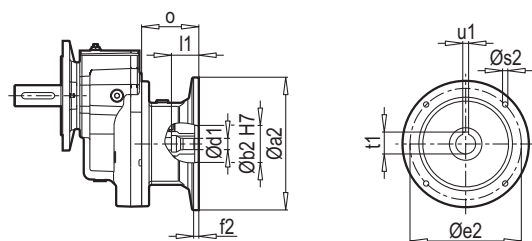

F 601 W

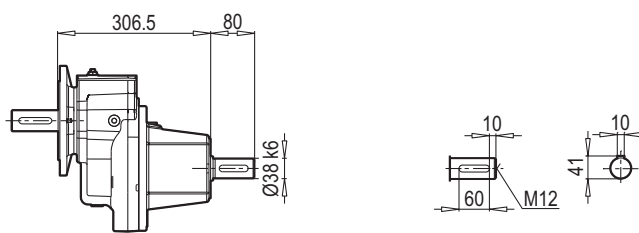

AF 601 PAM B5/B14

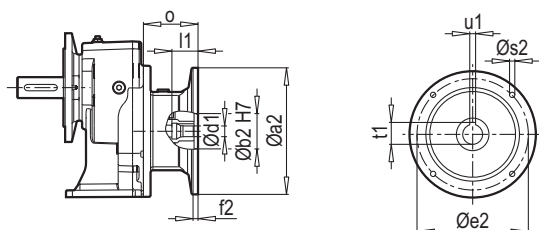

AF 601 W

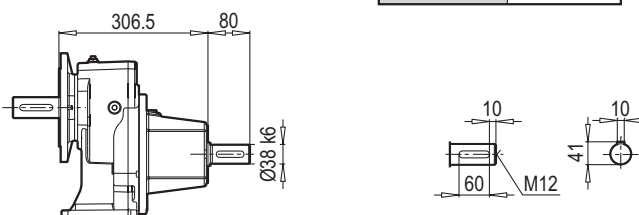

W ~ Kg	
A/F 601	45

AF-M 601 PAM B5/B14

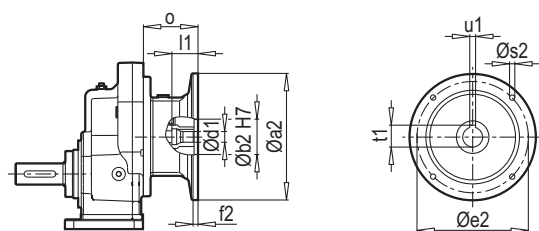

AF-M 601 W

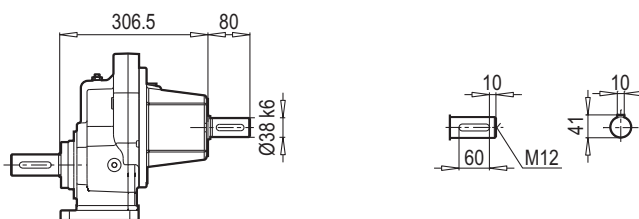

Typ / Type / Tipo Type / Tipo	PAM B5	Øa2	Øb2	Øe2	f2	Øs2	Ød1	l1	t1	u1	o
A/F 601	100	250	180	215	5.5	M12	28	62	31.3	8	76
	112	250	180	215	5.5	M12	28	62	31.3	8	76
	132	300	230	265	5.5	M12	38	82	41.3	10	101
	160	350	250	300	7	M16	42	112	45.3	12	148
	180	350	250	300	7	M16	48	112	51.8	14	148

~ Kg	
PAM B5	A/F 601
100	37
112	37
132	40
160	47
180	47

Typ / Type / Tipo Type / Tipo	PAM B14	Øa2	Øb2	Øe2	f2	Øs2	Ød1	l1	t1	u1	o
A/F 601	100	160	110	130	3.5	9	28	62	31.3	8	76
	112	160	110	130	3.5	9	28	62	31.3	8	76
	132	200	130	165	3.5	11	38	82	41.3	10	101

~ Kg	
PAM B14	A/F 601
100	34.5
112	34.5
132	38

A 602 - 603

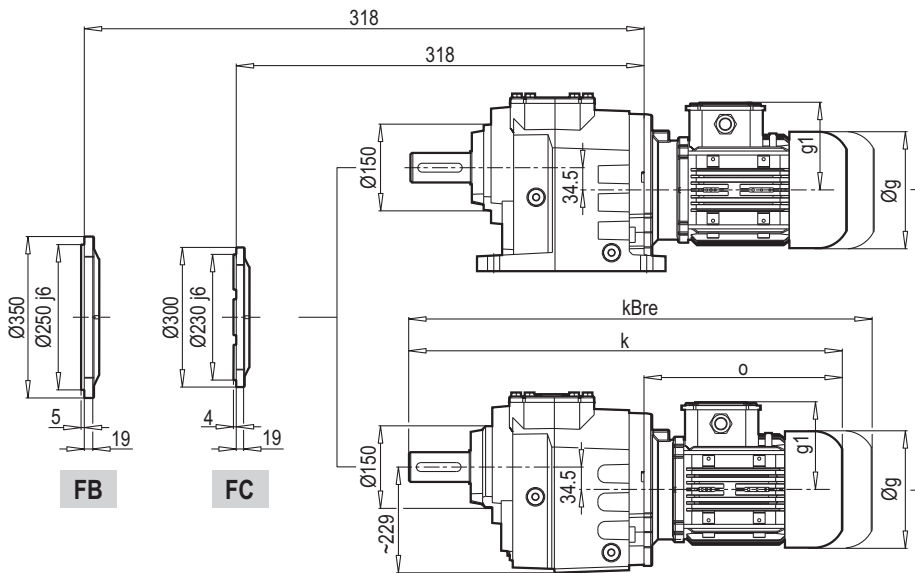
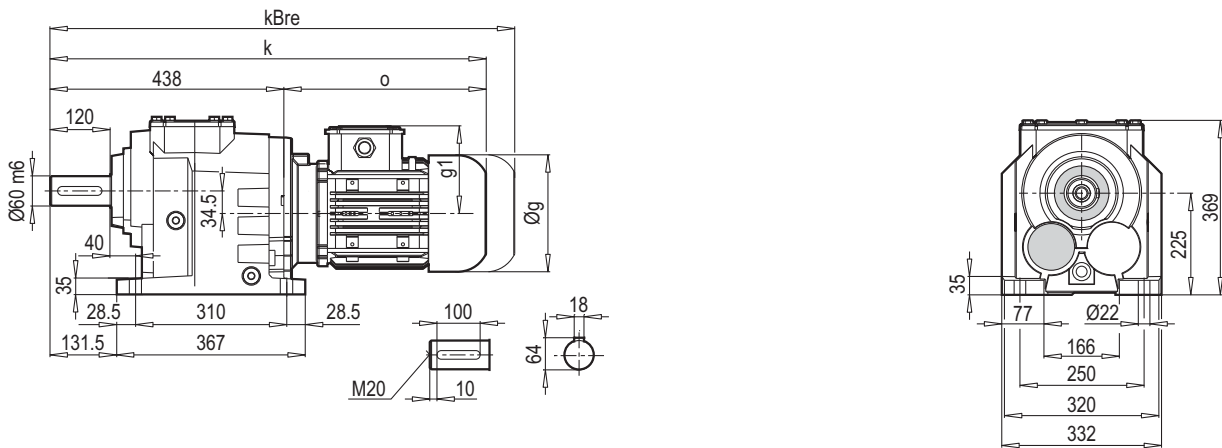

AF 602 - 603

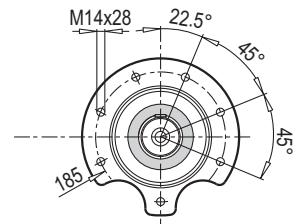

F 602 - 603

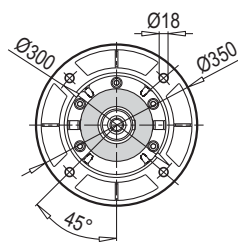
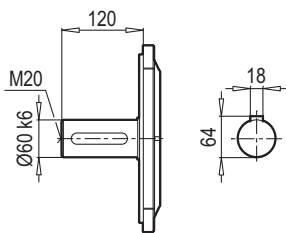

FB

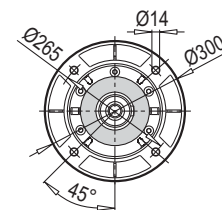

FC

	90 L	100 L	112 M	132 S	132 M	160 M/L	180 M/L	
g	193	217	232	279	279	323	370	
g1	151	160	168	182	182	200	248	
k	741	764	818	824	859	946	1011	
kBre	814	845	898	932	1000	1098	1173	
o	303	326	380	386	421	508	573	

A 602-603 PAM B5/B14

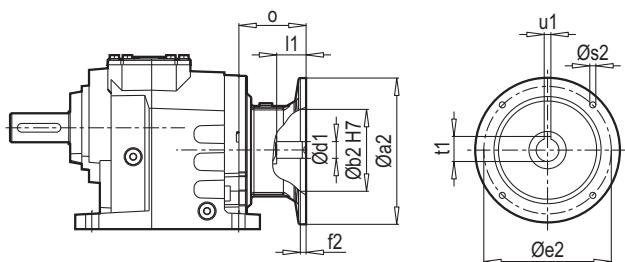

A 602-603 W

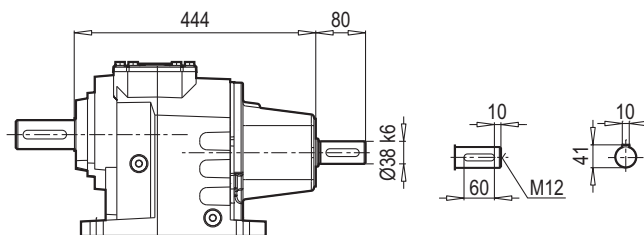

F 602-603 PAM B5/B14

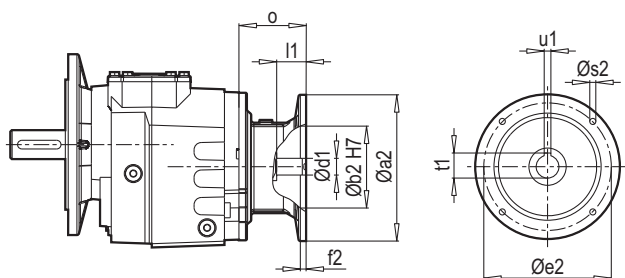

F 602-603 W

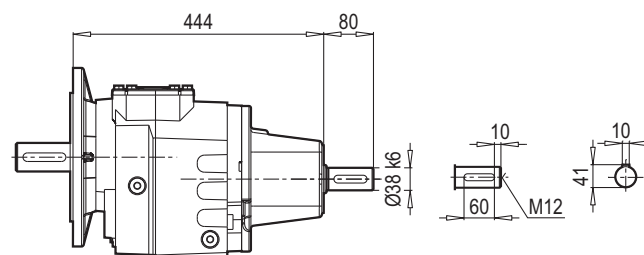

AF 602-603 PAM B5/B14

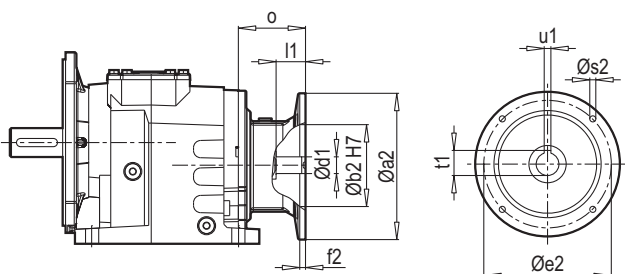

AF 602-603 W

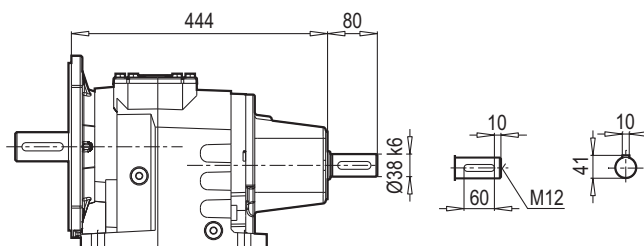

W ~ Kg	
A/F 602-603	90

Typ / Type / Tipo Type / Tipo	PAM B5	Øa2	Øb2	Øe2	f2	Øs2	Ød1	l1	t1	u1	o
A/F 602 A/F 603	90	200	130	165	5	M10	24	52	27.3	8	61
	100	250	180	215	5.5	M12	28	62	31.3	8	76
	112	250	180	215	5.5	M12	28	62	31.3	8	76
	132	300	230	265	5.5	M12	38	82	41.3	10	101
	160	350	250	300	7	M16	42	112	45.3	12	148
	180	350	250	300	7	M16	48	112	51.8	14	148

~ Kg	
PAM B5	A/F 602-603
90	81
100	85
112	85
132	88
160	94
180	94

Typ / Type / Tipo Type / Tipo	PAM B14	Øa2	Øb2	Øe2	f2	Øs2	Ød1	l1	t1	u1	o
A/F 602 A/F 603	90	140	95	115	3	9	24	52	27.3	8	61
	100	160	110	130	3.5	9	28	62	31.3	8	76
	112	160	110	130	3.5	9	28	62	31.3	8	76
	132	200	130	165	3.5	11	38	82	41.3	10	101

~ Kg	
PAM B14	A/F 602-603
90	78
100	80
112	80
132	86

A 701

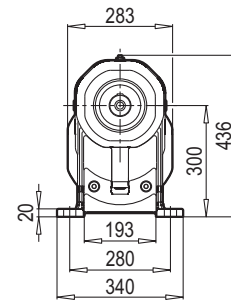
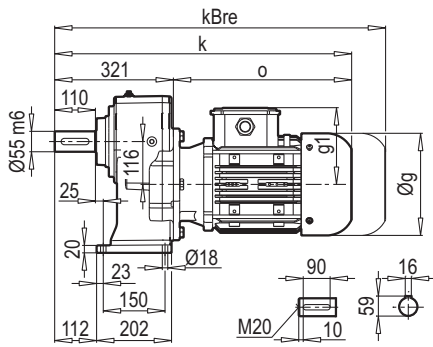

AF-M 701

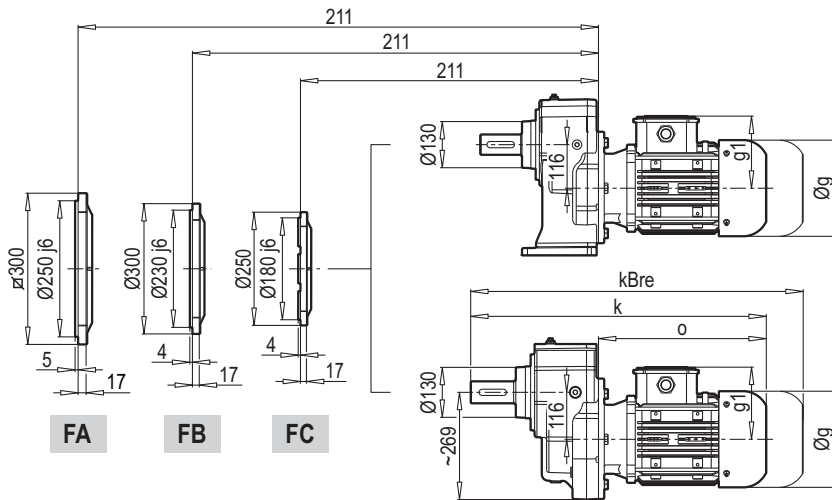
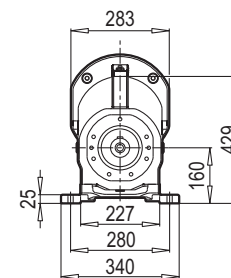
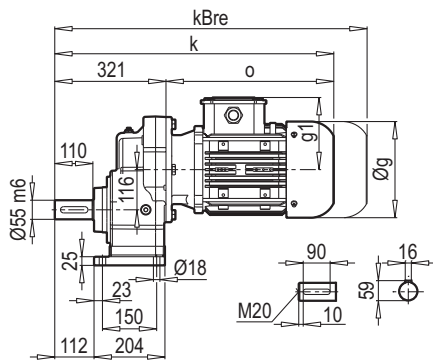

AF 701

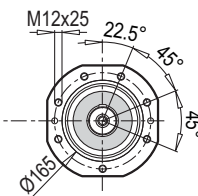

F 701

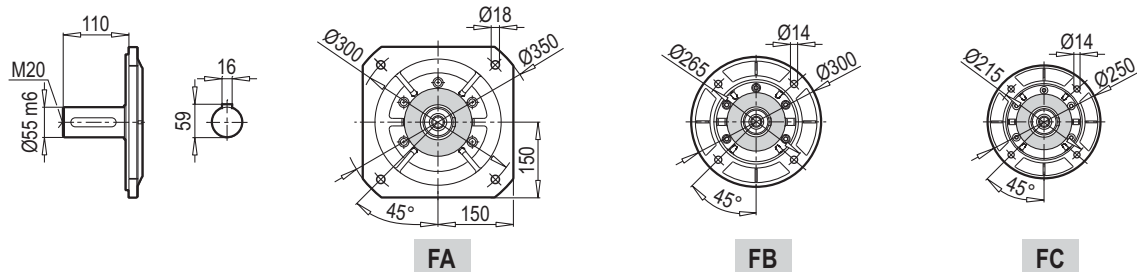

FA

FB

FC

	132 S	132 M	160 M/L	180 M/L	200 L			
g	279	279	323	370	415			
g1	182	182	200	248	260			
k	707	742	829	894	931			
kBre	815	883	981	1056	1078			
o	386	421	508	573	610			

A 701 PAM B5/B14

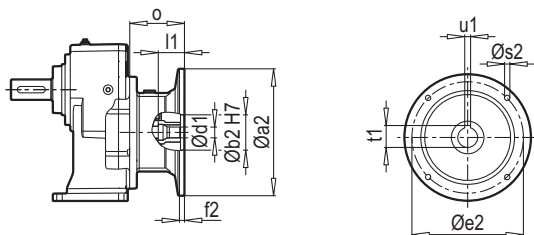

A 701 W

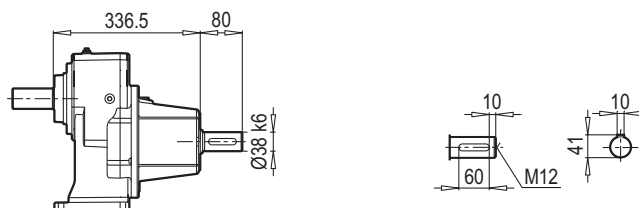

F 701 PAM B5/B14

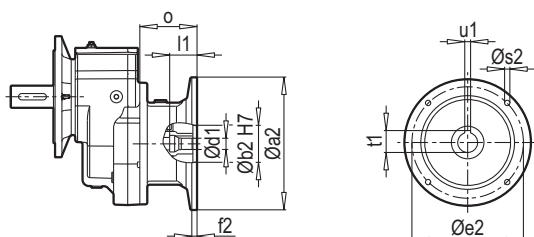

F 701 W

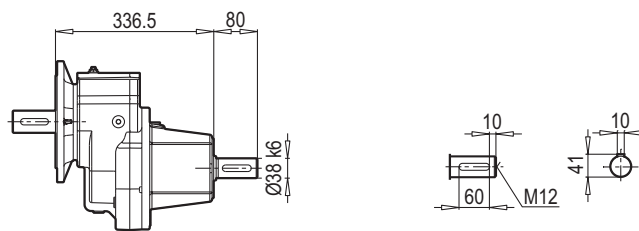

AF 701 PAM B5/B14

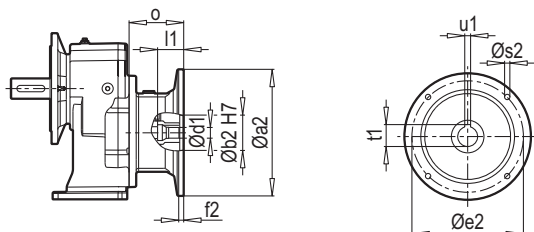

AF 701 W

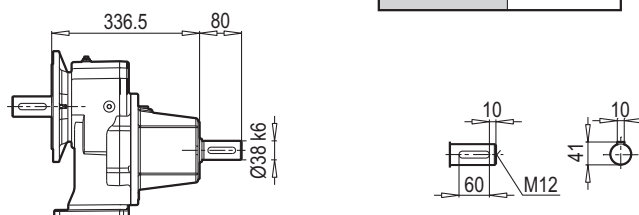

W ~ Kg	
A/F 701	49

AF-M 701 PAM B5/B14

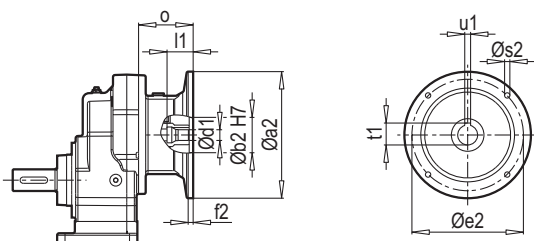

AF-M 701 W

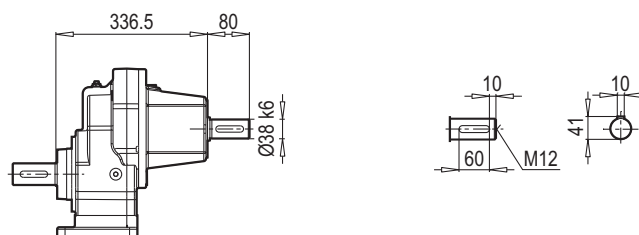

Typ / Type / Tipo Type / Tipo	PAM B5	Øa2	Øb2	Øe2	f2	Øs2	Ød1	l1	t1	u1	o
A/F 701	132	300	230	265	5.5	M12	38	82	41.3	10	101
	160	350	250	300	7	M16	42	112	45.3	12	148
	180	350	250	300	7	M16	48	112	51.8	14	148
	200	400	300	350	7	M16	55	112	59.3	16	185

~ Kg	
PAM B5	A/F 701
132	43
160	50
180	50
200	65

Typ / Type / Tipo Type / Tipo	PAM B14	Øa2	Øb2	Øe2	f2	Øs2	Ød1	l1	t1	u1	o
A/F 701	132	200	130	165	3.5	11	38	82	41.3	10	101

~ Kg	
PAM B14	A/F 701
132	41

A 702 - 703

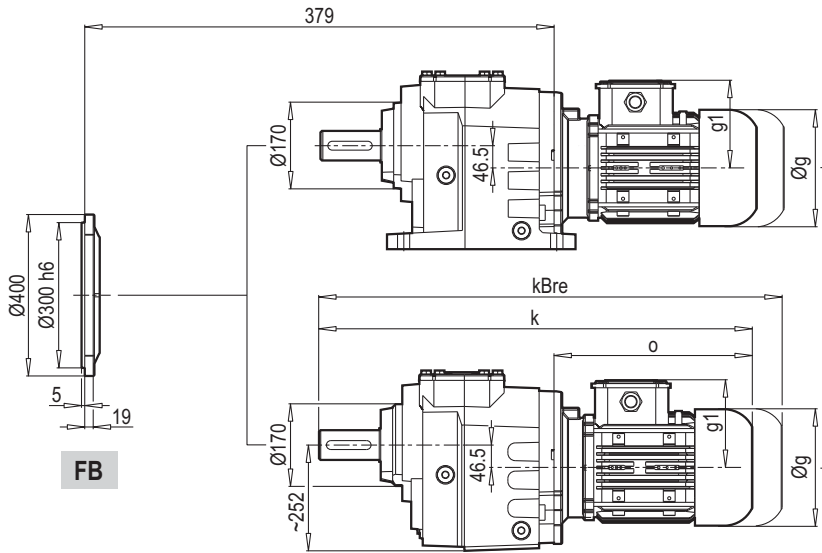
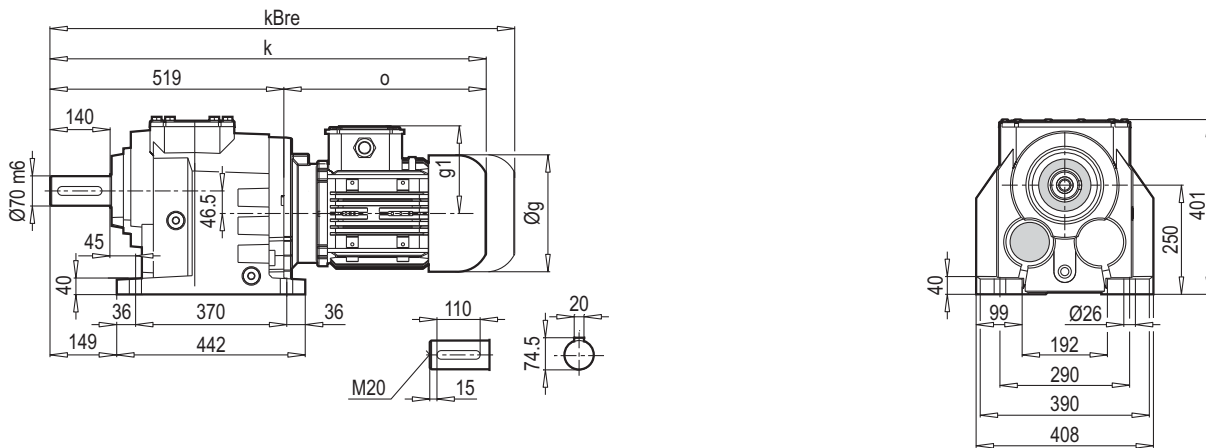

AF 702 - 703

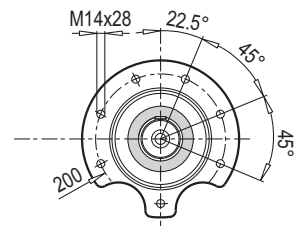

F 702 - 703

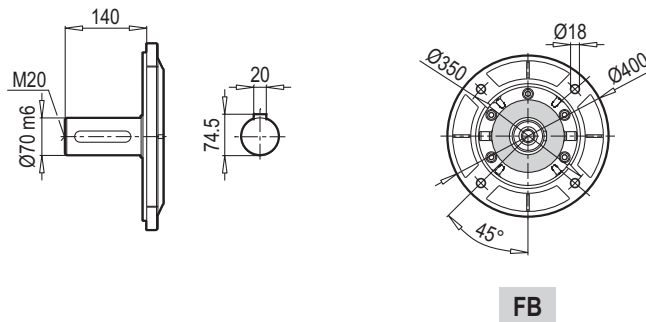

	100 L	112 M	132 S	132 M	160 M/L	180 M/L	200 L	
g	217	232	279	279	323	370	415	
g1	160	168	182	182	200	248	260	
k	845	899	905	940	1027	1092	1129	
kBre	926	979	1013	1081	1179	1254	1276	
o	326	380	386	421	508	573	610	

A 702-703 PAM B5/B14

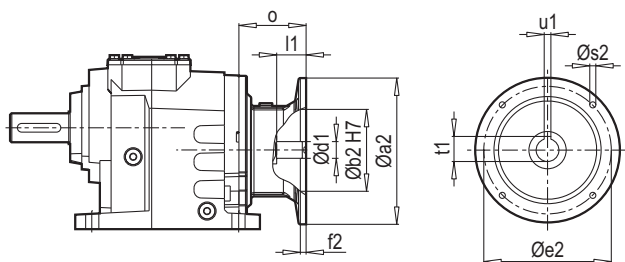

A 702-703 W

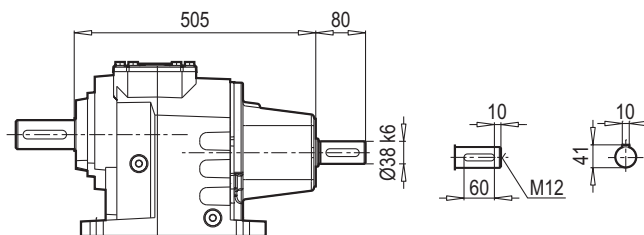

F 702-703 PAM B5/B14

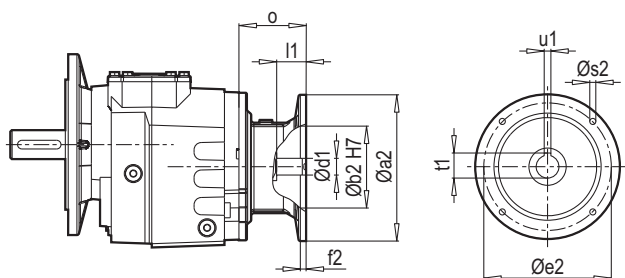

F 702-703 W

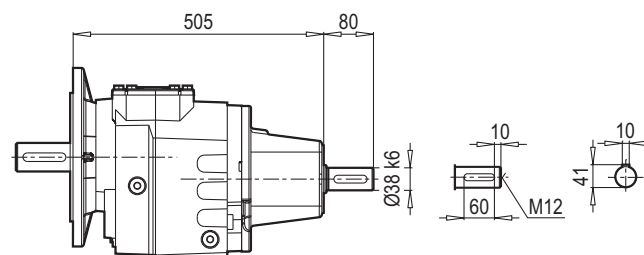

AF 702-703 PAM B5/B14

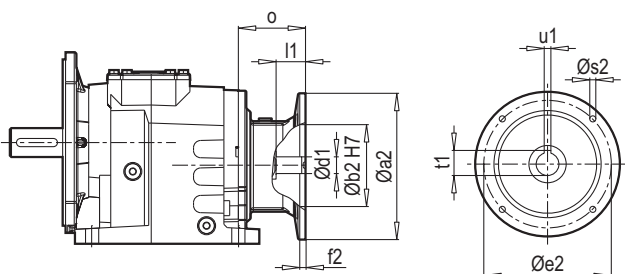

AF 702-703 W

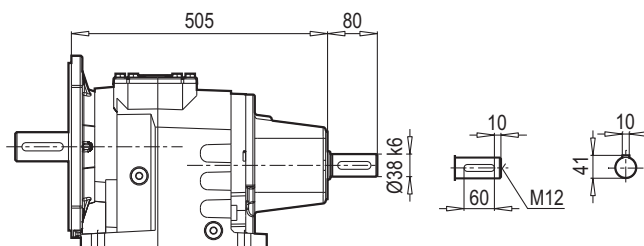

W ~ Kg	
A/F 702-703	119

Typ / Type / Tipo Type / Tipo	PAM B5	Øa2	Øb2	Øe2	f2	Øs2	Ød1	l1	t1	u1	o
A/F 702 A/F 703	100	250	180	215	5.5	M12	28	62	31.3	8	76
	112	250	180	215	5.5	M12	28	62	31.3	8	76
	132	300	230	265	5.5	M12	38	82	41.3	10	101
	160	350	250	300	7	M16	42	112	45.3	12	148
	180	350	250	300	7	M16	48	112	51.8	14	148
	200	400	300	350	7	M16	55	112	59.3	16	185

~ Kg	
PAM B5	A/F 702-703
100	114
112	114
132	117
160	123
180	123
200	139

Typ / Type / Tipo Type / Tipo	PAM B14	Øa2	Øb2	Øe2	f2	Øs2	Ød1	l1	t1	u1	o
A/F 702 A/F 703	100	160	110	130	3.5	9	28	62	31.3	8	76
	112	160	110	130	3.5	9	28	62	31.3	8	76
	132	200	130	165	3.5	11	38	82	41.3	10	101

~ Kg	
PAM B14	A/F 702-703
100	109
112	109
132	115

A 902 - 903

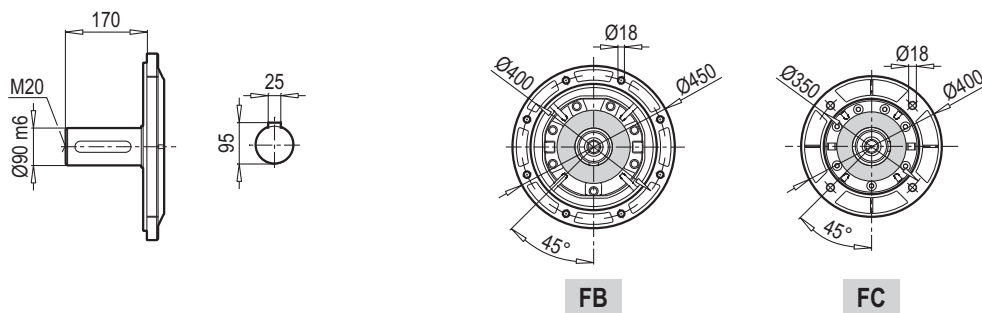
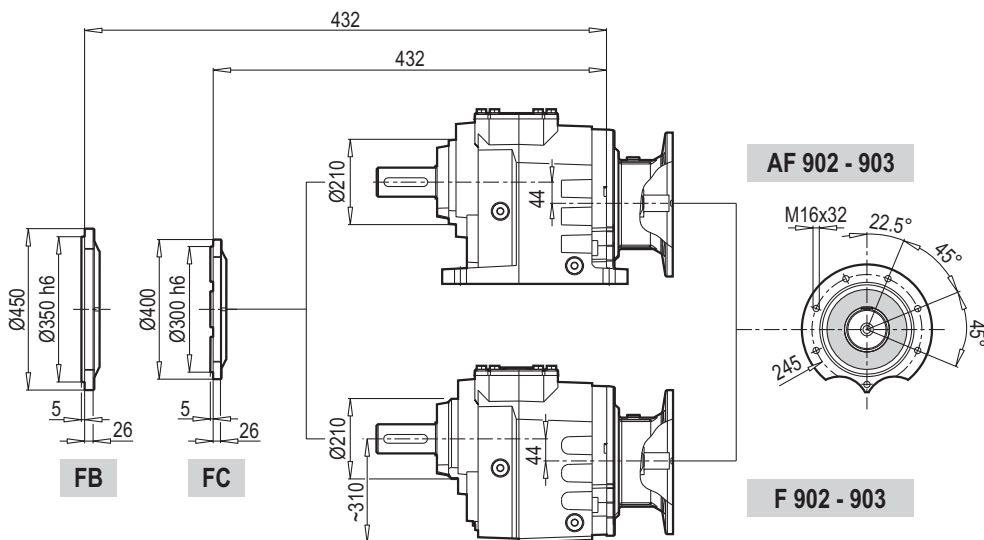
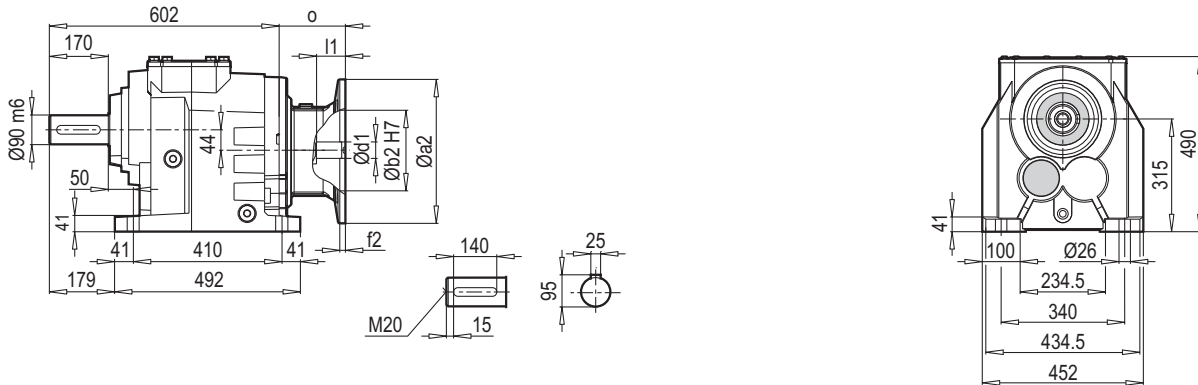

	132	160	180	200	225			
a2	300	350	350	400	450			
b2	230	250	250	300	350			
d1	38	42	48	55	60			
f2	5.5	7	7	7	7			
L	82	112	112	112	142			
u1	10	12	14	16	18			
t1	41.3	45.3	51.8	59.3	64.4			
o	76	124	124	161	161			

A 902-903 PAM B5/B14

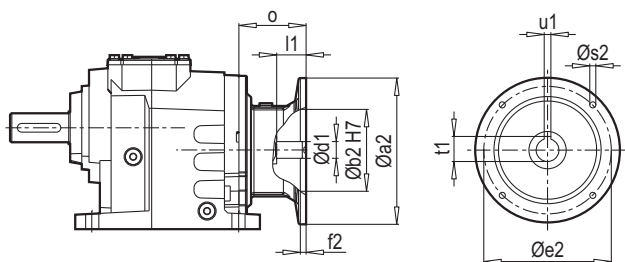

A 902-903 W

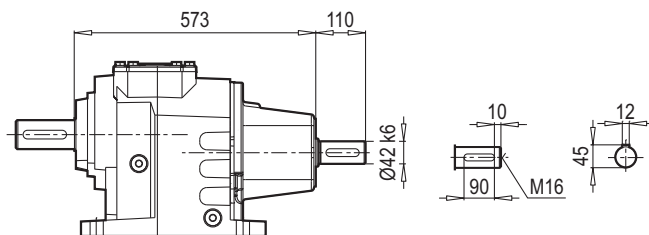

F 902-903 PAM B5/B14

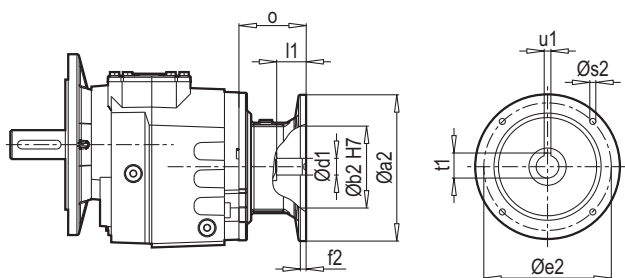

F 902-903 W

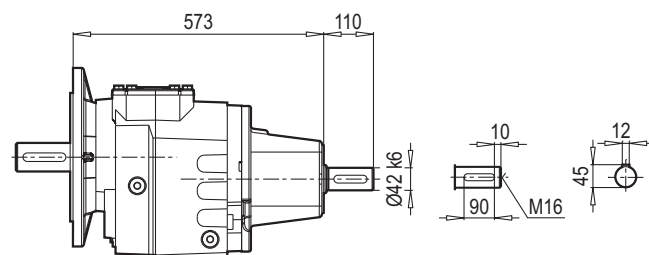

AF 902-903 PAM B5/B14

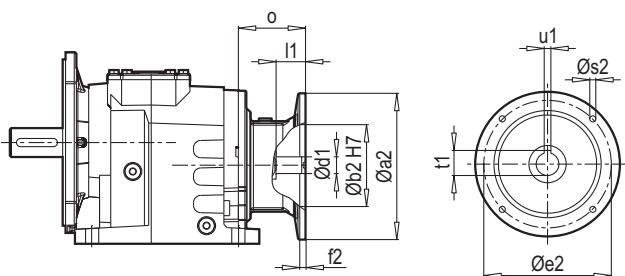

AF 902-903 W

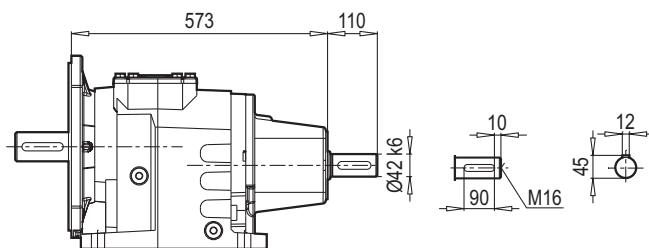

W ~ Kg	
A/F 902-903	195

Typ / Type / Tipo Type / Tipo	PAM B5	Øa2	Øb2	Øe2	f2	Øs2	Ød1	l1	t1	u1	o
A/F 902 A/F 903	132	300	230	265	5.5	M12	38	82	41.3	10	76
	160	350	250	300	7	M16	42	112	45.3	12	124
	180	350	250	300	7	M16	48	112	51.8	14	124
	200	400	300	350	7	M16	55	112	59.3	16	161
	225	450	350	400	7	M16	60	142	64.4	18	161

~ Kg	
PAM B5	A/F 902-903
132	182
160	190
180	190
200	205
225	208

Typ / Type / Tipo Type / Tipo	PAM B14	Øa2	Øb2	Øe2	f2	Øs2	Ød1	l1	t1	u1	o
A/F 903	132	200	130	165	3.5	11	38	82	41.3	10	76

~ Kg	
PAM B14	A/F 903
132	175



A series of horizontal dotted lines spanning the width of the page, intended for writing or drawing.

**Auswahltabellen von
W - PAM - IEC Adaptern**

Selection Tables
of W - PAM - IEC Adapters

Tabella si Selezione di
W - PAM - IEC Adattatore

Tableau de Sélection du
W - PAM - IEC Adaptateur

Tabla de Selección de
W - PAM - IEC Adaptador

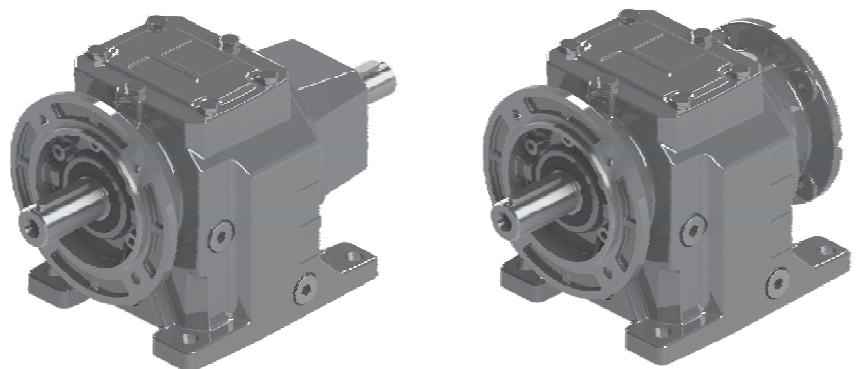
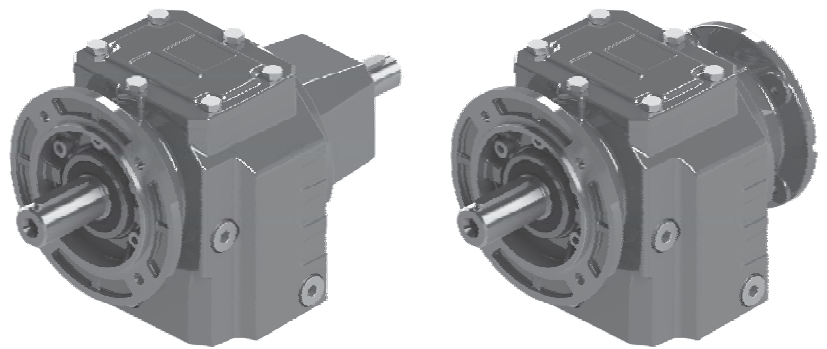
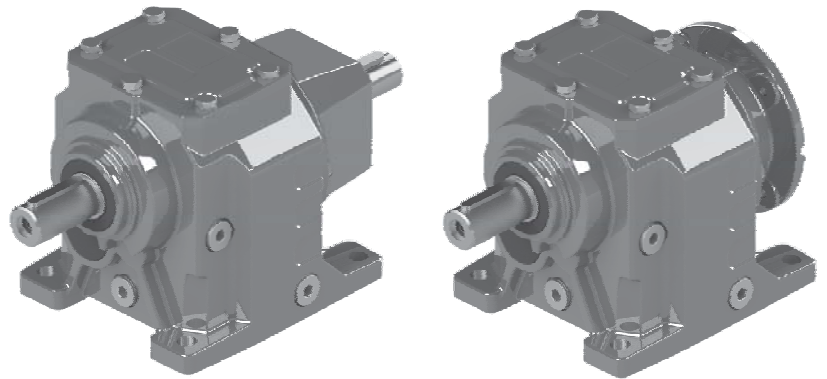

A/F

**A/F 301 ... 701
A/F 202 ... 902
A/F 253 ... 903**

Der Aufbau der Leistungstabellen für W - IEC und PAM-Adapter

Notify about performance tables for W and IEC adapter type
Struttura delle tabelle delle prestazioni degli adattatori W – IEC e PAM
La structure de la table de performance pour W - Adaptateur IEC et PAM
Estructura de Tablas de Rendimiento para Adaptador de W – IEC ve PAM

A 253 → **Getriebemotortyp /**
F 253 → Gear unit motor type / Tipo del motore con ingranaggi /
Type du moteur à engrenages / Tipo del motor con engranaje

Betriebsfaktor f_B kann aus den Motorauswahlseiten entnommen werden, da für die IEC montierten Getriebe die Motor Körpergröße und IEC Körpergröße die gleichen sind.

Service factor f_B could be seen from selection of geared motor tables. Because this value is same for geared motor and geared motor with IEC adapters.
Peri riduttori a montaggio IEC con grandezza del corpo motore uguale alla grandezza del corpo motore IEC il fattore di Servizio puo' essere rilevato dalle scelte di motori f_B .
Facteur de service f_B peut être prise à partir de la page de sélection de moteur, pour réducteurs IEC montée dont moteur taille du corps et IEC taille du corps sont les mêmes.
Factor de servicio para reductores con IEC montado, y con mismo tamaño de cuerpo de IEC y el cuerpo de motor, se puede encontrar en paginas de elección f_B motor.

Typ / Type / Tipo Type / Tipo	i_{ges}	4-pol 50Hz 1400rpm n2 [min-1]	M _{amax} $f_B=1$ 4 - pol. [Nm]	P_{1max} W $f_B \geq 1$			PAM - IEC						
				4 - pol. 1400rpm [kW]	FR1 [kN]	FR2 [kN]	$f_B \rightarrow$ 39 - 107						
A253 F253	245.76	5.7	200	0.12	1.4	5.5	63	71					
	197.21	7.1	200	0.15	1.4	5.5	63	71					
	178.56	7.8	200	0.16	1.4	5.5	63	71					
	143.29	9.8	200	0.20	1.4	5.5	63	71					
	123.58	11.3	200	0.24	1.3	5.5	63	71	80	90			
	108.02	13.0	200	0.27	1.3	5.5	63	71					
	100.12	14.0	200	0.29	1.3	5.5	63	71	80	90			
	74.76	18.7	200	0.39	1.3	5.5	63	71	80	90			
	66.56	21.0	200	0.44	1.3	5.5	63	71	80	90			
	53.41	26.2	200	0.55	1.3	5.5	63	71	80	90			

Verkleinerungsfaktor
Reduction ratio
Rapporto di riduzione
Rapport de réduction
Relación de de reducción

Abtriebsdrehzahl
Output speed
Velocità di uscita
Vitesse de sortie
Velocidad de salida

Abtriebsdrehmoment
Output torque
Momento di uscita
Moment de sortie
Momento de salida





Bei der Berechnung der maximalen Antriebskraft von Typ W werden keine kursiv Werte übernommen.
 f_B mit $P_{1max} = 1$.
 P_{1max} value which is *non-italic* is calculated when service factor f_B is equal to one.
Nel calcolo della forza motrice massima tipo W sono stati presi valori non in corsivo.
 P_{1max} e $f_B = 1$
Bien que la force maximale de conduite de type W est calculé, les valeurs italiques ne sont pas prises. f_B avec $P_{1max} = 1$
Los valores no cursivos fueron tomados al calcular la fuerza motriz tipo W.
 P_{1max} con $f_B = 1$

Zulässige max. radialkraft (Abtrieb)
Max. Permissible radial force (Output)
Máx. Forza radiale ammessa (Uscita)
Max. Force radiale admissible (Sortie)
Max. Fuerza radial admissible (Salida)









Zulässige max. radialkraft (Antrieb)
Max. Permissible radial force (Input)
Máx. Forza radiale ammessa (Entrada)
Max. Force radiale admissible (Entree)
Max. Fuerza radial admissible (Entrada)

IEC Motorgrößen und IEC-Standard-Ausgänge gemäß DIN 50347.
According to DIN EN 50347 IEC motor sizes. Le grandezze dei motori IEC e le uscite standard IEC sono conformi a DIN 50347.
Tailles de moteurs IEC et les sorties standards IEC est selon la norme DIN 50347.
Tamaño de motores de IEC y salidas estandares de IEC son conformes a DIN 50347.

























Bedruckte Bereiche zeigen, dass der IEC - Adapter für die IEC Motorgröße und den Verkleinerungsfaktor anwendbar ist.
This area which is colorless is shown IEC adapter is applicable for this IEC motor size and reduction ratio. Gli spazi con cifre degli adattatori IEC, indicano che la grandezza del motore IEC é conforme al rapporto di trasmissione. Zones numériques indiquent que l'adaptateur IEC est adapté pour IEC taille du moteur et taux de change. Áreas con números indican que es adaptador de IEC, es conforme a tamaño del motor IEC y al ratio de cambios.

Typ / Type / Tipo Type / Tipo	iges	4-pol 50Hz 1400rpm n2 [min-1]	M _{amax} f _B =1 4 - pol. [Nm]	P _{1max} W f _B ≥ 1			PAM - IEC																						
				4 - pol. 1400rpm [kW]	FR1 [kN]	FR2 [kN]	f _B →  39 - 107																						
A202 F202 W   111 + PAM - IEC   111	63.59	22.0	50	0.12	-	2.5	56	63	71																				
	55.03	25.4	50	0.13	-	2.5	56	63	71																				
	49.05	28.5	46	0.14	-	2.5	56	63	71																				
	42.20	33.2	50	0.17	-	2.5	56	63	71																				
	36.45	38.4	54	0.22	-	2.5	56	63	71																				
	32.41	43.2	55	0.25	-	2.5	56	63	71																				
	27.75	50.5	54	0.29	-	2.5	56	63	71																				
	24.78	56.5	55	0.33	-	2.5	56	63	71																				
	22.26	62.9	55	0.36	-	2.5	56	63	71																				
	21.36	65.5	55	0.38	-	2.5	56	63	71																				
	19.23	72.8	55	0.42	-	2.5	56	63	71																				
	17.37	80.6	55	0.46	-	2.5	56	63	71																				
	15.75	88.9	55	0.51	-	2.5	56	63	71																				
	14.42	97.1	51	0.52	-	2.5	56	63	71																				
	13.23	105.8	47	0.52	-	2.5	56	63	71																				
	11.52	121.5	50	0.55	-	2.5	56	63	71																				
	10.03	139.6	55	0.55	-	2.5	56	63	71																				
	8.93	156.8	55	0.55	-	2.5	56	63	71																				
	8.03	174.3	55	0.55	-	2.5	56	63	71																				
	7.21	194.2	55	0.55	-	2.5	56	63	71																				
	6.55	213.7	53	0.55	-	2.5	56	63	71																				
	5.98	234.1	55	0.55	-	2.5	56	63	71																				
	5.49	255.0	55	0.55	-	2.5	56	63	71																				
	5.33	262.7	55	0.55	-	2.5	56	63	71																				
	4.79	292.3	53	0.55	-	2.5	56	63	71																				
	4.29	326.3	50	0.55	-	2.5	56	63	71																				
	3.90	359.0	45	0.55	-	2.5	56	63	71																				
	3.56	393.3	48	0.55	-	2.5	56	63	71																				
3.26	429.4	47	0.55	-	2.5	56	63	71																					
2.97	471.4	46	0.55	-	2.5	56	63	71																					
2.83	494.7	45	0.55	-	2.5	56	63	71																					
2.55	549.0	41	0.55	-	2.5	56	63	71																					
2.31	606.1	39	0.55	-	2.5	56	63	71																					
2.12	660.4	36	0.55	-	2.5	56	63	71																					

























Typ / Type / Tipo Type / Tipo	iges	4-pol 50Hz 1400rpm n2 [min-1]	M _{amax} f _B =1 4 - pol. [Nm]	P _{1max} W f _B ≥ 1			PAM - IEC							
				4 - pol. 1400rpm [kW]	FR1 [kN]	FR2 [kN]	f _B → 39 - 107							
A 202 G	81.41	17.2	83	0.15	1.2	2.8	56	63	71	80	90			
F 202 G	70.05	20.0	72	0.15	1.2	2.8	56	63	71	80	90			
W	62.38	22.4	64	0.15	1.2	2.8	56	63	71	80	90			
54.05	54.05	25.9	85	0.23	1.2	2.8	56	63	71	80	90			
113	46.41	30.2	85	0.27	1.2	2.8	56	63	71	80	90			
+	41.38	33.8	85	0.30	1.2	2.8	56	63	71	80	90			
PAM - IEC	38.72	36.2	85	0.32	1.2	2.8	56	63	71	80	90			
34.55	34.55	40.5	86	0.36	1.2	2.8	56	63	71	80	90			
113	31.03	45.1	92	0.43	1.2	2.8	56	63	71	80	90			
	27.66	50.6	92	0.49	1.2	2.8	56	63	71	80	90			
	24.83	56.4	92	0.54	1.2	2.8	56	63	71	80	90			
	22.44	62.4	92	0.60	1.2	2.8	56	63	71	80	90			
	20.35	68.8	85	0.61	1.2	2.8	56	63	71	80	90			
	18.63	75.1	84	0.66	1.2	2.8	56	63	71	80	90			
	15.74	88.9	85	0.79	1.2	2.8	56	63	71	80	90			
	13.56	103.2	85	0.92	1.2	2.8	56	63	71	80	90			
	12.09	115.8	87	1.05	1.2	2.8	56	63	71	80	90			
	11.41	122.7	85	1.09	1.2	2.8	56	63	71	80	90			
	10.85	129.0	86	1.16	1.2	2.8	56	63	71	80	90			
	9.81	142.7	85	1.27	1.2	2.8	56	63	71	80	90			
	8.75	160.0	88	1.47	1.2	2.8	56	63	71	80	90			
	7.81	179.3	82	1.50	1.2	2.8	56	63	71	80	90			
	7.04	198.9	82	1.50	1.2	2.8	56	63	71	80	90			
	6.41	218.4	82	1.50	1.2	2.8	56	63	71	80	90			
	5.74	243.9	77	1.50	1.2	2.8	56	63	71	80	90			
	5.16	271.3	83	1.50	1.2	2.8	56	63	71	80	90			
	4.63	302.4	72	1.50	1.2	2.8	56	63	71	80	90			
	4.19	334.1	65	1.50	1.2	2.8	56	63	71	80	90			
	3.81	367.5	59	1.50	1.2	2.8	56	63	71	80	90			
	3.44	407.0	54	1.50	1.2	2.8	56	63	71	80	90			
	3.24	432.1	54	1.50	1.2	2.8	56	63	71	80	90			
	2.95	474.6	50	1.50	1.2	2.8	56	63	71	80	90			
	2.74	510.9	46	1.50	1.2	2.8	56	63	71	80	90			
	2.51	557.8	43	1.50	1.2	2.8	56	63	71	80	90			
	2.31	606.1	43	1.50	1.2	2.8	56	63	71	80	90			

Typ / Type / Tipo Type / Tipo	iges	4-pol 50Hz 1400rpm n2 [min-1]	M _{amax} f _B =1 4 - pol. [Nm]	P _{1max} W f _B ≥ 1			PAM - IEC							
				4 - pol. 1400rpm [kW]	FR1 [kN]	FR2 [kN]	f _B →  39 - 107							
A253 F253 W   115 + PAM - IEC   115	245.76	5.7	200	0.12	1.4	5.5	63	71						
	197.21	7.1	200	0.15	1.4	5.5	63	71						
	178.56	7.8	200	0.16	1.4	5.5	63	71						
	143.29	9.8	200	0.20	1.4	5.5	63	71						
	123.58	11.3	200	0.24	1.3	5.5	63	71	80	90				
	108.02	13.0	200	0.27	1.3	5.5	63	71						
	99.17	14.1	200	0.30	1.3	5.5	63	71	80	90				
	74.76	18.7	200	0.39	1.3	5.5	63	71	80	90				
	66.56	21.0	200	0.44	1.3	5.5	63	71	80	90				
	53.41	26.2	200	0.55	1.3	5.5	63	71	80	90				
A252 F252 W   115 + PAM - IEC   115	47.93	29.2	200	0.61	1.3	5.5	71	80	90					
	42.00	33.3	200	0.70	1.2	5.5	71	80	90					
	38.46	36.4	200	0.76	1.2	5.5	71	80	90					
	33.38	41.9	200	0.88	1.2	5.5	71	80	90					
	30.15	46.4	200	0.97	1.2	5.3	71	80	90					
	26.79	52.3	200	1.09	1.1	5.0	71	80	90					
	24.19	57.9	200	1.21	1.1	4.8	71	80	90					
	23.04	60.8	200	1.27	1.1	4.7	71	80	90	100	112			
	20.19	69.3	200	1.45	1.1	4.4	71	80	90					
	18.49	75.7	200	1.59	1.0	4.2	71	80	90	100	112			
	17.05	82.1	190	1.63	1.0	4.1	71	80	90	100	112			
	14.91	93.9	170	1.67	1.0	4.1	71	80	90	100	112			
	13.94	100.4	170	1.79	1.0	3.9	71	80	90	100	112			
	11.97	117.0	145	1.78	1.0	3.9	71	80	90	100	112			
	10.32	135.7	140	1.99	0.9	3.7	71	80	90	100	112			
	9.02	155.2	130	2.11	0.9	3.6	71	80	90	100	112			
	7.93	176.5	125	2.31	0.8	3.4	71	80	90	100	112			
	6.36	220.0	105	2.42	0.8	3.3	71	80	90	100	112			
	4.80	291.8	95	2.90	0.7	3.0	71	80	90	100	112			













Typ / Type / Tipo Type / Tipo	iges	4-pol 50Hz 1400rpm n2 [min-1]	M _{amax} f _B =1 4 - pol. [Nm]	P _{1max} W f _B ≥ 1			PAM - IEC											
				4 - pol. 1400rpm [kW]	FR1 [kN]	FR2 [kN]	f _B → 39 - 107											
A303 F303 W 165.33 119 + PAM - IEC 86.96 119	282.17	5.0	300	0.16	1.4	6.6	63	71										
	227.56	6.2	300	0.19	1.4	6.6	63	71										
	205.01	6.8	300	0.21	1.4	6.6	63	71										
	165.33	8.5	300	0.27	1.4	6.6	63	71										
	141.89	9.9	300	0.31	1.4	6.6	63	71	80	90								
	125.65	11.1	300	0.35	1.3	6.6	63	71										
	114.42	12.2	300	0.38	1.3	6.6	63	71	80	90								
	86.96	16.1	300	0.51	1.3	6.6	63	71	80	90								
	76.42	18.3	300	0.58	1.3	6.6	63	71	80	90								
	61.63	22.7	300	0.71	1.3	6.6	63	71	80	90								
A302 F302 W 38.33 119 + PAM - IEC 26.45 119	55.03	25.4	280	0.75	1.3	6.6	71	80	90									
	48.22	29.0	280	0.85	1.2	6.6	71	80	90									
	44.38	31.5	280	0.93	1.2	6.6	71	80	90									
	38.33	36.5	280	1.07	1.2	6.6	71	80	90									
	34.62	40.4	280	1.19	1.2	6.6	71	80	90									
	30.91	45.3	280	1.33	1.1	6.6	71	80	90									
	27.92	50.1	280	1.47	1.1	6.6	71	80	90									
	26.45	52.9	260	1.44	1.1	6.6	71	80	90	100	112							
	23.49	59.6	260	1.62	1.0	6.3	71	80	90									
	21.33	65.6	250	1.72	1.0	6.1	71	80	90	100	112							
	19.29	72.6	250	1.90	1.0	5.8	71	80	90	100	112							
	16.21	86.3	250	2.26	0.9	5.4	71	80	90	100	112							
	13.81	101.4	250	2.65	0.8	5.0	71	80	90	100	112							
	12.00	116.7	250	3.05	0.7	4.7	71	80	90	100	112							
	10.50	133.4	240	3.35	0.6	4.5	71	80	90	100	112							
	9.11	153.7	210	3.38	0.6	4.4	71	80	90	100	112							
7.34	190.6	160	3.19	0.7	4.4	71	80	90	100	112								
5.58	250.8	160	4.20	0.4	3.9	71	80	90	100	112								
A301 F301 W 5.58 117 + PAM - IEC 3.16 117	8.88	157.7	55	0.91	1.2	1.0	71	80	90									
	7.78	180.0	50	0.94	1.2	1.0	71	80	90									
	6.18	226.5	50	1.19	1.2	0.9	71	80	90									
	5.58	250.7	50	1.31	1.2	0.9	71	80	90									
	5.08	275.8	45	1.30	1.2	0.9	71	80	90									
	4.27	328.1	45	1.55	1.1	0.8	71	80	90									
	3.65	383.9	45	1.81	1.1	0.8	71	80	90									
	3.16	443.3	40	1.86	1.1	0.7	71	80	90									
	2.76	506.9	30	1.59	1.1	0.7	71	80	90									
	2.59	540.4	30	1.70	1.1	0.7	71	80	90									
2.04	686.8	25	1.80	1.1	0.7	71	80	90										
1.47	953.2	25	2.50	1.0	0.6	71	80	90										

Typ / Type / Tipo Type / Tipo	iges	4-pol 50Hz 1400rpm n2 [min-1]	M _{amax} f _B =1 4 - pol. [Nm]	P _{1max} W f _B ≥ 1			PAM - IEC										
				4 - pol. 1400rpm [kW]	FR1 [kN]	FR2 [kN]	f _B →  39 - 107										
A353 F353 W   123 + PAM - IEC   123	268.00	5.2	500	0.27	1.4	8.0	63	71									
	216.67	6.5	500	0.34	1.3	8.0	63	71									
	194.72	7.2	500	0.38	1.3	8.0	63	71									
		157.42	8.9	500	0.47	1.3	8.0	63	71								
	 123	134.76	10.4	500	0.54	1.3	8.0	63	71	80	90						
	+	108.95	12.9	500	0.67	1.3	8.0	63	71	80	90						
	PAM - IEC	90.51	15.5	500	0.81	1.3	8.0	63	71	80	90						
		72.58	19.3	500	1.01	1.2	8.0	63	71	80	90						
	 123	58.68	23.9	500	1.25	1.2	8.0	63	71	80	90						
A352 F352 W   123 + PAM - IEC   123	56.95	24.6	490	1.26	1.2	8.0	71	80	90								
	49.88	28.1	490	1.44	1.1	8.0	71	80	90								
	46.04	30.4	490	1.56	1.1	8.0	71	80	90								
		39.59	35.4	490	1.81	1.1	8.0	71	80	90	100	112					
	 123	33.50	41.8	490	2.14	1.0	8.0	71	80	90							
	+	32.01	43.7	490	2.24	1.0	8.0	71	80	90	100	112					
	PAM - IEC	28.89	48.5	490	2.49	1.0	7.9	71	80	90	100	112					
		26.59	52.6	490	2.70	0.9	7.6	71	80	90	100	112					
	 123	25.13	55.7	470	2.74	0.9	7.5	71	80	90	100	112					
		22.03	63.6	470	3.13	0.9	7.1	71	80	90	100	112					
		20.31	68.9	460	3.32	0.8	6.9	71	80	90	100	112					
		18.30	76.5	460	3.68	0.8	6.5	71	80	90	100	112					
		16.88	83.0	450	3.91	0.7	6.3	71	80	90	100	112					
		14.52	96.4	430	4.34	0.6	6.0		80	90	100	112					
		11.74	119.3	390	4.87	0.6	5.7		80	90	100	112					
		9.75	143.6	370	5.56	0.4	5.3		80	90	100	112					
		8.73	160.4	340	5.71	0.4	5.2		80	90	100	112					
	7.06	198.4	290	6.02	0.3	5.1		80	90	100	112						
	5.86	238.8	260	6.50	0.3	4.8		80	90	100	112						
A351 F351 W   121 + PAM - IEC   121	8.50	164.7	100	1.72	1.2	2.5	71	80	90								
	7.44	188.1	100	1.97	1.1	2.5	71	80	90								
	5.91	236.9	100	2.48	1.1	2.3	71	80	90	100	112						
		5.33	262.5	100	2.75	1.0	2.2	71	80	90	100	112					
	 121	4.85	288.9	95	2.87	1.0	2.2	71	80	90	100	112					
	+	4.07	344.3	90	3.24	1.0	2.0	71	80	90	100	112					
	PAM - IEC	3.75	373.3	90	3.52	1.0	2.0	71	80	90	100	112					
		3.22	434.5	80	3.64	0.9	1.9	71	80	90	100	112					
	 121	2.62	534.5	70	3.92	0.9	1.8	71	80	90	100	112					
		2.17	646.2	60	4.06	0.9	1.7		80	90	100	112					
	1.45	964.4	60	6.06	0.6	1.5		80	90	100	112						
	1.30	1074.4	40	4.50	0.8	1.5		80	90	100	112						

Typ / Type / Tipo Type / Tipo	iges	4-pol 50Hz 1400rpm n2 [min-1]	M _{amax} f _B =1 4 - pol. [Nm]	P _{1max} W f _B ≥ 1			PAM - IEC								
				4 - pol. 1400rpm [kW]	FR1 [kN]	FR2 [kN]	f _B → 39 - 107								
A403 F403 W 186.14 127 + PAM - IEC 118.13 127	267.75	5.2	850	0.47	2.8	12.0	71	80	90						
	234.50	6.0	850	0.53	2.8	12.0	71	80	90						
	215.01	6.5	850	0.58	2.8	12.0	71	80	90						
	186.14	7.5	850	0.67	2.7	12.0	71	80	90	100	112				
	170.55	8.2	850	0.73	2.7	12.0	71	80	90						
	149.47	9.4	850	0.83	2.7	12.0	71	80	90	100	112				
	135.37	10.3	850	0.92	2.7	12.0	71	80	90	100	112				
	118.13	11.9	850	1.05	2.7	12.0	71	80	90	100	112				
	94.86	14.8	850	1.31	2.7	12.0	71	80	90	100	112				
	85.91	16.3	850	1.45	2.6	12.0	71	80	90	100	112				
	68.25	20.5	850	1.83	2.6	12.0		80	90	100	112				
	54.81	25.5	850	2.27	2.5	12.0		80	90	100	112				
	49.64	28.2	850	2.51	2.5	12.0		80	90	100	112				
	A402 F402 W 31.50 127 + PAM - IEC 19.94 127	45.38	30.9	850	2.75	2.4	12.0	80	90	100	112				
39.72		35.2	850	3.14	2.4	12.0	80	90	100	112					
36.44		38.4	800	3.22	2.4	12.0	80	90	100	112					
31.50		44.4	850	3.96	2.3	12.0	80	90	100	112	132				
28.89		48.5	800	4.06	2.3	12.0	80	90	100	112					
25.30		55.3	850	4.93	2.1	12.0	80	90	100	112	132				
22.91		61.1	850	5.44	2.1	12.0	80	90	100	112	132				
19.94		70.2	850	6.25	1.9	11.7	80	90	100	112	132				
17.37		80.6	830	7.00	1.8	11.1	80	90	100	112	132				
16.01		87.4	800	7.33	1.8	10.8	80	90	100	112	132				
14.50		96.6	700	7.08	1.8	10.9	80	90	100	112	132				
12.44		112.5	700	8.25	1.7	10.2	80	90	100	112	132				
11.46		122.2	650	8.32	1.7	10.1	80	90	100	112	132				
9.20		152.2	600	9.56	1.5	9.4	80	90	100	112	132				
8.33	168.0	600	10.55	1.3	9.0	80	90	100	112	132					
7.22	193.9	550	11.17	1.3	8.7	80	90	100	112	132					
5.80	241.5	550	13.91	0.9	7.9	80	90	100	112	132					
5.25	266.7	500	13.96	0.9	7.8	80	90	100	112	132					
A401 F401 W 5.17 125 + PAM - IEC 3.11 125	8.25	169.7	170	3.02	2.7	3.7	80	90	100	112					
	7.22	193.8	170	3.45	2.6	3.7	80	90	100	112					
	5.73	244.4	170	4.35	2.5	3.4	80	90	100	112					
	5.17	271.0	170	4.82	2.5	3.2	80	90	100	112					
	4.69	298.4	160	5.00	2.5	3.1	80	90	100	112					
	3.93	355.9	150	5.59	2.4	3.0	80	90	100	112					
	3.63	386.2	150	6.07	2.4	2.9	80	90	100	112					
	3.11	450.0	130	6.13	2.4	2.8	80	90	100	112					
2.52	554.7	120	6.97	2.3	2.6	80	90	100	112						
2.08	672.0	120	8.44	2.1	2.4	80	90	100	112						
1.31	1066.7	80	8.94	2.1	2.2	80	90	100	112						

Typ / Tipo Type / Tipo	iges	4-pol 50Hz 1400rpm n2 [min-1]	M _{amax} f _B =1 4 - pol. [Nm]	P _{1max} W f _B ≥ 1			PAM - IEC									
				4 - pol. 1400rpm [kW]	FR1 [kN]	FR2 [kN]	f _B →  39 - 107									
A503 F503 W   131 + PAM - IEC   131	222.59	6.3	1800	1.19	2.9	18.0	80	90	90							
	194.86	7.2	1800	1.35	2.9	18.0	80	90	90							
	178.98	7.8	1800	1.47	2.8	18.0	80	90	90							
		162.21	8.6	1800	1.63	2.8	18.0	80	90	90						
	 131	154.52	9.1	1800	1.71	2.8	18.0	80	90	90	100	112	132			
		142.00	9.9	1800	1.86	2.8	18.0	80	90	90	100	112				
	+ PAM - IEC	124.25	11.3	1800	2.12	2.8	18.0	80	90	90	100	112	132			
		112.61	12.4	1800	2.34	2.7	18.0	80	90	90	100	112	132			
	 131	97.80	14.3	1800	2.70	2.7	18.0	80	90	90	100	112	132			
		85.33	16.4	1800	3.09	2.7	18.0	80	90	90	100	112	132			
		78.64	17.8	1800	3.36	2.6	18.0	80	90	90	100	112	132			
		71.27	19.6	1800	3.70	2.6	18.0	80	90	90	100	112	132			
		56.21	24.9	1600	4.17	2.5	18.0	80	90	90	100	112	132			
	A502 F502 W   131 + PAM - IEC   131	48.77	28.7	1600	4.81	2.4	18.0	80	90	100	112	132				
43.32		32.3	1600	5.41	2.4	18.0	80	90	100	112	132					
39.21		35.7	1600	5.98	2.3	17.7	80	90	100	112	132					
		34.83	40.2	1600	6.73	2.2	16.7	80	90	100	112	132				
 131		31.57	44.3	1600	7.43	2.1	16.0	80	90	100	112	132				
		28.26	49.5	1600	8.30	2.0	15.1	80	90	100	112	132				
+ PAM - IEC		26.98	51.9	1600	8.69	2.0	14.8			100	112	132	160			
		23.14	60.5	1600	10.14	1.8	13.7			100	112	132	160			
 131		21.69	64.5	1600	10.81	1.7	13.2			100	112	132	160			
		19.66	71.2	1600	11.93	1.6	12.6			100	112	132	160			
		18.81	74.4	1500	11.69	1.6	12.7			100	112	132	160			
		16.86	83.0	1500	13.04	1.5	12.1			100	112	132	160			
		15.13	92.6	1500	14.54	1.3	11.4			100	112	132	160			
		13.71	102.1	1400	14.97	1.3	11.3			100	112	132	160			
		11.20	125.0	1100	14.39	1.3	11.5					132	160			
		9.01	155.4	900	14.65	1.3	11.2					132	160			
		8.16	171.5	800	14.36	1.3	11.2					132	160			
	7.55	185.5	800	15.54	1.2	10.8					132	160				
	6.07	230.6	700	16.91	1.0	10.3					132	160				
	5.50	254.5	700	18.65	0.8	9.8					132	160				
A501 F501 W   129 + PAM - IEC   129	8.56	163.6	350	6.00	2.5	4.0	80	90	100	112	132					
	7.60	184.2	350	6.75	2.4	4.0	80	90	100	112	132					
	6.17	227.0	340	8.08	2.3	3.9	80	90	100	112	132					
		5.62	249.3	330	8.62	2.2	3.7	80	90	100	112	132				
	 129	4.73	295.8	320	9.91	2.1	3.5			100	112	132				
		4.06	344.9	320	11.56	1.9	3.3			100	112	132				
	+ PAM - IEC	3.78	370.6	310	12.03	1.9	3.2			100	112	132				
		3.30	424.2	310	13.77	1.7	3.0			100	112	132				
	 129	2.58	541.9	280	15.89	1.5	2.8			100	112	132				
		1.97	712.3	230	17.15	1.4	2.7					132				
	1.46	960.8	220	22.13	0.9	2.4					132					
	1.32	1057.1	200	22.14	0.9	2.3					132					

Typ / Type / Tipo Type / Tipo	iges	4-pol 50Hz 1400rpm n2 [min-1]	M _{amax} f _B =1 4 - pol. [Nm]	P _{1max} W f _B ≥ 1			PAM - IEC									
				4 - pol. 1400rpm [kW]	FR1 [kN]	FR2 [kN]	f _B → 39 - 107									
A603 F603 W 181.13 135 + PAM - IEC 121.02 135	242.67	5.8	3600	2.17	4.0	22.0	90	100	112	132						
	215.56	6.5	3500	2.38	4.0	22.0	90	100	112	132						
	194.31	7.2	3500	2.64	4.0	22.0	90	100	112	132						
	181.13	7.7	3500	2.83	4.0	22.0	90	100	112	132						
	160.90	8.7	3500	3.19	3.9	22.0	90	100	112	132						
	143.57	9.8	3500	3.57	3.9	22.0	90	100	112	132						
	134.25	10.4	3500	3.82	3.9	22.0		100	112	132	160					
	121.02	11.6	3500	4.24	3.9	22.0		100	112	132	160					
	100.21	14.0	3500	5.12	3.9	22.0		100	112	132	160					
	93.60	15.0	3500	5.48	3.8	22.0		100	112	132	160					
	84.37	16.6	3500	6.08	3.8	22.0		100	112	132	160					
	79.98	17.5	3500	6.42	3.8	22.0		100	112	132	160					
	69.87	20.0	3500	7.34	3.7	22.0		100	112	132	160					
	55.75	25.1	3500	9.20	3.7	22.0				132	160					
	A602 F602 W 38.00 135 + PAM - IEC 25.57 135	50.91	27.5	3300	9.50	3.6	22.0	100	112	132						
		45.27	30.9	3300	10.69	3.6	22.0	100	112	132	160					
40.81		34.3	3300	11.85	3.5	21.7	100	112	132	160						
38.00		36.8	2800	10.80	3.6	22.0	100	112	132							
33.79		41.4	3200	13.88	3.4	20.0	100	112	132	160						
30.35		46.1	3200	15.46	3.4	18.9	100	112	132	160						
28.36		49.4	3300	17.06	3.3	17.8	100	112	132	160	180					
25.57		54.8	3300	18.92	3.2	16.8	100	112	132	160	180					
23.66		59.2	3300	20.45	3.1	16.1	100	112	132	160	180					
21.17		66.1	3200	22.16	3.1	15.4	100	112	132	160	180					
19.59		71.5	3200	23.94	3.0	14.7	100	112	132	160	180					
17.60		79.5	3200	26.65	2.9	13.8	100	112	132	160	180					
15.87		88.2	3200	29.56	2.7	12.9	100	112	132	160	180					
13.14		106.5	3100	34.59	2.5	11.8	100	112	132	160	180					
10.91		128.3	3000	40.31	2.2	10.8			132	160	180					
9.83		142.4	2800	41.74	2.2	10.8			132	160	180					
8.14	171.9	2500	45.01	2.0	10.6			132	160	180						
6.92	202.4	2300	48.74	1.8	10.4			132	160	180						
6.24	224.5	2000	47.02	1.9	10.9			132	160	180						
5.16	271.1	1800	51.10	1.7	10.5			132	160	180						
A601 F601 W 5.20 133 + PAM - IEC 3.23 133	8.30	168.7	650	11.48	3.4	5.0	100	112	132	160						
	7.45	187.8	650	12.78	3.4	5.0	100	112	132	160						
	6.15	227.5	640	15.25	3.3	4.9	100	112	132	160						
	5.20	269.2	620	17.48	3.1	4.6	100	112	132	160	180					
	4.81	290.9	620	18.89	3.1	4.4	100	112	132	160	180					
	4.28	327.3	610	20.90	3.0	4.2			132	160	180					
	3.65	383.6	600	24.10	2.8	3.9	100	112	132	160	180					
	3.23	433.8	600	27.25	2.7	3.7	100	112	132	160	180					
	2.44	572.7	550	32.98	2.4	3.4			132	160	180					
	2.00	700.0	450	32.98	2.4	3.3			132	160	180					
1.38	1011.1	450	47.64	1.7	2.8			132	160	180						
1.27	1103.8	400	46.23	1.8	2.8			132	160	180						

Typ / Type / Tipo Type / Tipo	iges	4-pol 50Hz 1400rpm n2 [min-1]	M _{amax} f _B =1 4 - pol. [Nm]	P _{1max} W f _B ≥ 1			PAM - IEC													
				4 - pol. 1400rpm [kW]	FR1 [kN]	FR2 [kN]	f _B →  39 - 107													
A703 F703 W   139 + PAM - IEC   139	260.15	5.4	5000	2.82	3.9	30.0	100	112	132											
	231.34	6.1	5000	3.17	3.9	30.0	100	112	132	160	180									
	207.78	6.7	5000	3.53	3.9	30.0	100	112	132	160	180									
	189.54	7.4	5000	3.87	3.9	30.0	100	112	132	160	180									
	173.11	8.1	5000	4.23	3.9	30.0	100	112	132	160	180									
	155.48	9.0	5000	4.71	3.8	30.0	100	112	132	160	180									
	144.94	9.7	5000	5.06	3.8	30.0	100	112	132	160	180	200								
	128.35	10.9	5000	5.71	3.8	30.0	100	112	132	160	180									
	118.75	11.8	5000	6.17	3.8	30.0	100	112	132	160	180	200								
	108.46	12.9	5000	6.76	3.8	30.0	100	112	132	160	180	200								
	100.38	13.9	5000	7.30	3.7	30.0	100	112	132	160	180	200								
	89.95	15.6	5000	8.15	3.7	30.0	100	112	132	160	180	200								
	83.35	16.8	5000	8.79	3.7	30.0	100	112	132	160	180	200								
	73.70	19.0	5000	9.95	3.6	30.0	100	112	132	160	180	200								
	67.31	20.8	5000	10.89	3.6	30.0	100	112	132	160	180	200								
	55.75	25.1	5000	13.15	3.5	30.0			132	160	180	200								
	45.67	30.7	5000	16.05	3.4	30.0			132	160	180	200								
	A702 F702 W   139 + PAM - IEC   139	44.67	31.3	5000	16.41	3.4	30.0	132	160	180										
		36.60	38.3	5000	20.03	3.2	30.0	132	160	180										
		33.43	41.9	5000	21.93	3.2	29.5	132	160	180										
30.27		46.2	5000	24.21	3.1	28.0	132	160	180											
27.87		50.2	5000	26.30	3.0	26.8	132	160	180	200										
24.80		56.4	5000	29.55	2.9	25.2	132	160	180											
22.84		61.3	5000	32.10	2.8	24.1	132	160	180	200										
20.86		67.1	5000	35.14	2.6	22.9	132	160	180	200										
19.60		71.4	5000	37.40	2.6	22.1	132	160	180	200										
17.18		81.5	4800	40.95	2.4	21.1	132	160	180	200										
14.08		99.5	4600	47.90	2.1	19.4	132	160	180	200										
12.86		108.9	4400	50.17	2.0	19.0	132	160	180	200										
10.53		132.9	4000	55.68	1.8	18.2		160	180	200										
8.63		162.3	3800	64.57	1.5	16.9		160	180	200										
7.88		177.7	3700	68.83	1.3	16.3		160	180	200										
7.20		194.6	3600	73.34	1.1	15.8		160	180	200										
5.90		237.5	3200	79.57	0.9	15.3		160	180	200										
5.38		260.0	3000	81.68	0.8	15.2		160	180	200										
A701 F701 W   137 + PAM - IEC   137		7.80	179.5	1000	18.79	3.2	6.0	132	160	180										
		6.33	221.1	900	20.83	3.1	6.0	132	160	180										
	5.29	264.9	880	24.41	3.0	5.8	132	160	180											
	4.87	287.7	870	26.21	2.9	5.6	132	160	180	200										
	4.18	335.2	850	29.84	2.7	5.3	132	160	180	200										
	3.63	385.5	850	34.31	2.6	5.0	132	160	180	200										
	3.19	438.8	820	37.68	2.4	4.8	132	160	180	200										
	3.00	466.7	800	39.09	2.4	4.7	132	160	180	200										
	2.52	555.6	800	46.54	2.1	4.3	132	160	180	200										
	2.03	688.1	750	54.04	1.8	4.0	132	160	180	200										
	1.84	761.4	700	55.81	1.7	3.9		160	180	200										
	1.44	969.2	700	71.04	1.1	3.5		160	180	200										
1.26	1114.3	650	75.84	0.9	3.4		160	180	200											

Typ / Type / Tipo Type / Tipo	iges	4-pol 50Hz 1400rpm n2 [min-1]	M _{amax} f _B =1 4 - pol. [Nm]	P _{1max} W f _B ≥ 1			PAM - IEC									
				4 - pol. 1400rpm [kW]	FR1 [kN]	FR2 [kN]	f _B → 39 - 107									
A903 F903 W 139.41 141 + PAM - IEC 96.13 141	205.73	6.8	8000	5.70	8.0	55.0	132	160	180							
	185.64	7.5	8000	6.32	8.0	55.0	132	160	180							
	154.07	9.1	8000	7.61	8.0	55.0	132	160	180							
	139.41	10.0	8000	8.41	8.0	55.0	132	160	180							
	128.36	10.9	8000	9.14	8.0	55.0	132	160	180	200						
	115.83	12.1	8000	10.13	8.0	55.0	132	160	180	200						
	104.41	13.4	8000	11.23	8.0	55.0	132	160	180							
	96.13	14.6	8000	12.20	8.0	55.0	132	160	180	200						
	86.43	16.2	8000	13.57	8.0	55.0	132	160	180	200						
	79.13	17.7	8000	14.82	8.0	55.0	132	160	180	200						
	71.40	19.6	8000	16.43	8.0	54.3	132	160	180	200						
	63.02	22.2	8000	18.61	8.0	51.2	132	160	180	200						
	59.26	23.6	8000	19.79	8.0	49.6	132	160	180	200						
	53.66	26.1	8000	21.86	8.0	47.2	132	160	180	200						
	48.50	28.9	8000	24.18	8.0	44.9		160	180	200						
	A902 F902 W 26.38 141 + PAM - IEC 15.50 141	42.47	33.0	8000	27.61	5.1	42.3	160	180	200	225					
		38.33	36.5	8000	30.60	5.1	40.1	160	180	200	225					
31.81		44.0	8000	36.87	5.1	36.3	160	180	200	225						
26.38		53.1	8000	44.46	5.1	32.3	160	180	200	225						
23.80		58.8	8000	49.28	5.1	30.8	160	180	200	225						
19.75		70.9	8000	59.37	5.1	27.5	160	180	200	225						
17.18		81.5	7900	67.42	5.1	25.5	160	180	200	225						
15.50		90.3	7800	73.77	5.1	24.2	160	180	200	225						
12.86		108.8	7300	83.19	5.1	22.9	160	180	200	225						
10.28		136.2	7200	102.69	5.0	20.0	160	180	200	225						
9.28		150.9	6500	102.74	5.0	20.7	160	180	200	225						
7.70		181.9	5300	100.94	5.0	21.9	160	180	200	225						
6.89		203.2	5000	106.38	4.0	21.5	160	180	200	225						
6.22		225.2	4900	115.54	4.0	20.6	160	180	200	225						
5.16		271.3	4600	130.69	4.0	19.4	160	180	200	225						



A large area of the page is filled with horizontal dotted lines, providing a template for writing or drawing.

DE ALLGEMEINE TEILELISTE

EN GENERAL PART LIST

IT GENERALE ELENCO DELLE PARTI

FR GÉNÉRALE LA LISTE DES PIÈCES

ES LISTE DE PIEZAS EN GENERAL

A 252...902

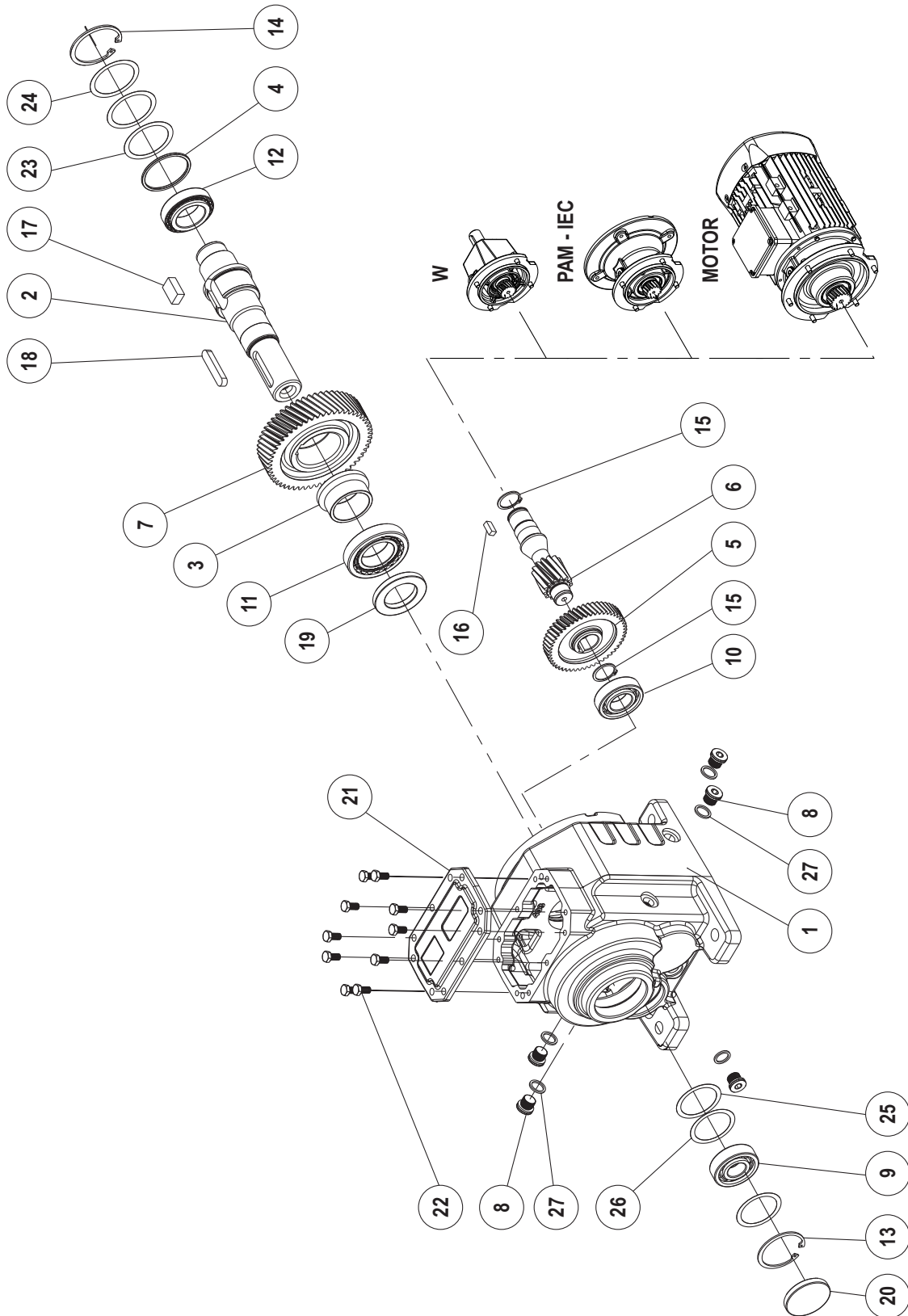

DE ALLGEMEINE TEILELISTE

EN GENERAL PART LIST

IT GENERALE ELENCO DELLE PARTI

FR GÉNÉRALE LA LISTE DES PIÈCES

ES LISTE DE PIEZAS EN GENERAL

01 **Getriebegehäuse**
02 **Abtriebswelle**
03 **Distanzbuchse**
04 **Stützscheibe**
05 **Abtriebsrad**
06 **Ritzel Welle**
07 **Abtriebsrad**
08 **Ölstopfen**
09 **Kugellager**
10 **Kugellager**
11 **Kugellager**
12 **Kugellager**
13 **Sicherungsring**
14 **Sicherungsring**
15 **Sicherungsring**
16 **Passfeder**
17 **Passfeder**
18 **Passfeder**
19 **Wellendichtring**
20 **Verschlusskappe**
21 **Gehäusedeckel**
22 **Schraube**
23 **Scheibe**
24 **Scheibe**
25 **Scheibe**
26 **Scheibe**
27 **Dichtung**

Gear Case
Solid Shaft
Spacer
Washer
Driving Gear
Pinion Shaft
Driven Gear
Oil Plug
Bearing
Bearing
Bearing
Bearing
Circlip
Circlip
Circlip
Key
Key
Key
Shaft Seal
Locking cap
Case Cover
Bolt
Shim
Shim
Shim
Shim
Shim
Seal

Ingranaggi Box
Albero di uscita
Distanziatore
Rondella
Ingranaggio Conduttore
Pignone
Ingranaggio Condotto
Olio Tappo
Cuscinetto
Cuscinetto
Cuscinetto
Cuscinetto
Anello di sicurezza
Anello di sicurezza
Anello di sicurezza
Chiavetta
Chiavetta
Chiavetta
Tenuta Albero
Tappo di chiusura
Coperchio della custodia
Bullone
Shim
Shim
Shim
Shim
Sigillo

01 **Carter d'engrenage**
02 **Arbre de sortie**
03 **Doville entretoise**
04 **Rondelle support**
05 **Rove d'entrée**
06 **Arbre intermédiaire**
07 **Rove desortie**
08 **Visde vidange**
09 **Roulement a billes**
10 **Roulement a billes**
11 **Roulement a billes**
12 **Roulement a billes**
13 **Circlip**
14 **Circlip**
15 **Circlip**
16 **Clavette**
17 **Clavette**
18 **Clavette**
19 **Bague d'étancheite**
20 **Bouchon**
21 **Couvercle du carter**
22 **Boulonner**
23 **Rondella d'ajustage**
24 **Rondella d'ajustage**
25 **Rondella d'ajustage**
26 **Rondella d'ajustage**
27 **Joint**

La caja de engranajes
Eje salida
Espaciador
El apoyo el disco
Engranaje conducido
Deleje del piñón
Engranaje conducido
Tapón
Rodamiento de bolas
Rodamiento de bolas
Rodamiento de bolas
Rodamiento de bolas
Anillo de seguridad
Anillo de seguridad
Anillo de seguridad
Clave
Clave
Clave
Sello del eje
Tapón de cierre
Tapá de la carcasa
Atornillor
Calce
Calce
Calce
Calce
Sellar

DE ALLGEMEINE TEILELISTE

EN GENERAL PART LIST

IT GENERALE ELENCO DELLE PARTI

FR GÉNÉRALE LA LISTE DES PIÈCES

ES LISTE DE PIEZAS EN GENERAL

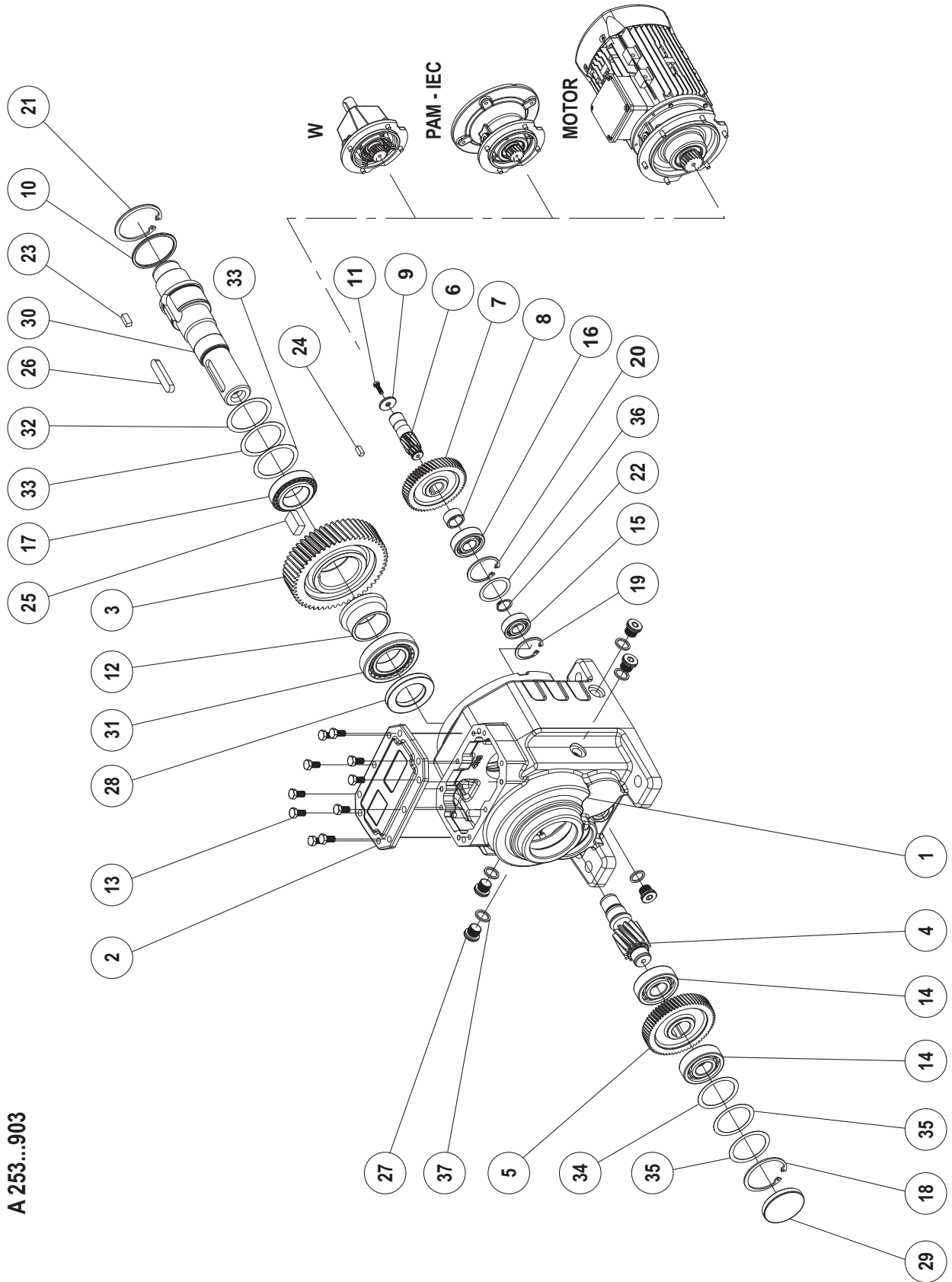

A 253...903

DE ALLGEMEINE TEILELISTE

EN GENERAL PART LIST

IT GENERALE ELENCO DELLE PARTI

FR GÉNÉRALE LA LISTE DES PIÈCES

ES LISTE DE PIEZAS EN GENERAL

01	Getriebegehäuse	Gear Case	Ingranaggi Box	Carter d'engrenage	La caja de engranajes
02	Gehäusedeckel	Case Cover	Coperchio della custodia	Couvercle du carter	Tapá de la carcasa
03	Ausgangswelle	Output Shaft	Albero di uscita	l'arbre de sortie	Eje de salida
04	Abtriebsritzelle	Output Pinion Shaft	Pignone di uscita	Arbre de pignon de sortie	El eje de piñón de salida
05	Abtriebsrad	Driven Gear	Ingranaggio Condotta	Rove de sortie	Engranaje conducido
06	Ritzel Welle	Pinion Shaft	Pignone	Arbre intermédiaire	Deleje del piñón
07	Abtriebsrad	Driving Gear	Ingranaggio Conduttore	Rove d'entrée	Engranaje con ducido
08	Abstandhalter	Spacer	Distanziatore	Doville entretoise	Espaciador
09	Stützscheibe	Washer	Rondella	Rondelle support	El apoyo a disco
10	Stützscheibe	Washer	Rondella	Rondelle support	El apoyo a disco
11	Schraube	Bolt	Bullone	Boulonner	Atornillar
12	Distanzbuchse	Spacer	Distanziatore	Doville entretoise	Espaciador
13	Schraube	Bolt	Bullone	Boulonner	Atornillar
14	Kugellager	Bearing	Cuscinetto	Roulement a billes	Rodamiento de bolas
15	Kugellager	Bearing	Cuscinetto	Roulement a billes	Rodamiento de bolas
16	Kugellager	Bearing	Cuscinetto	Roulement a billes	Rodamiento de bolas
17	Kugellager	Bearing	Cuscinetto	Roulement a billes	Rodamiento de bolas
18	Sicherungsring	Circlip	Anello di sicurezza	Circlip	Anillo de seguridad
19	Sicherungsring	Circlip	Anello di sicurezza	Circlip	Anillo de seguridad
20	Sicherungsring	Circlip	Anello di sicurezza	Circlip	Anillo de seguridad
21	Sicherungsring	Circlip	Anello di sicurezza	Circlip	Anillo de seguridad
22	Sicherungsring	Circlip	Anello di sicurezza	Circlip	Anillo de seguridad
23	Passfeder	Key	Chiavetta	Clavette	Clave
24	Passfeder	Key	Chiavetta	Clavette	Clave
25	Passfeder	Key	Chiavetta	Clavette	Clave
26	Passfeder	Key	Chiavetta	Clavette	Clave
27	Ölstopfen	Oil Plug	Olio Tappo	Visde vidange	Tapón
28	Wellendichtring	Shaft Seal	Tenuta Albero	Bague d'étancheite	Sello del eje
29	Öleinfüllstutzen Tasse	Locking cap	Tappo di chiusura	Bouchon	Tapón de cierre
30	Abtriebswelle	Solid Shaft	Albero di uscita	Arbre de sortie	Eje de salida
31	Kugellager	Bearing	Cuscinetto	Roulement a billes	Rodamiento de bolas
32	Scheibe	Shim	Shim	Rondelle d'ajustage	Calce
33	Scheibe	Shim	Shim	Rondelle d'ajustage	Calce
34	Scheibe	Shim	Shim	Rondelle d'ajustage	Calce
35	Scheibe	Shim	Shim	Rondelle d'ajustage	Calce
36	Scheibe	Shim	Shim	Rondelle d'ajustage	Calce
37	Dichtung	Seal	Sigillo	Joint	Sellar

DE ALLGEMEINE TEILELISTE

EN GENERAL PART LIST

IT GENERALE ELENCO DELLE PARTI

FR GÉNÉRALE LA LISTE DES PIÈCES

ES LISTE DE PIEZAS EN GENERAL

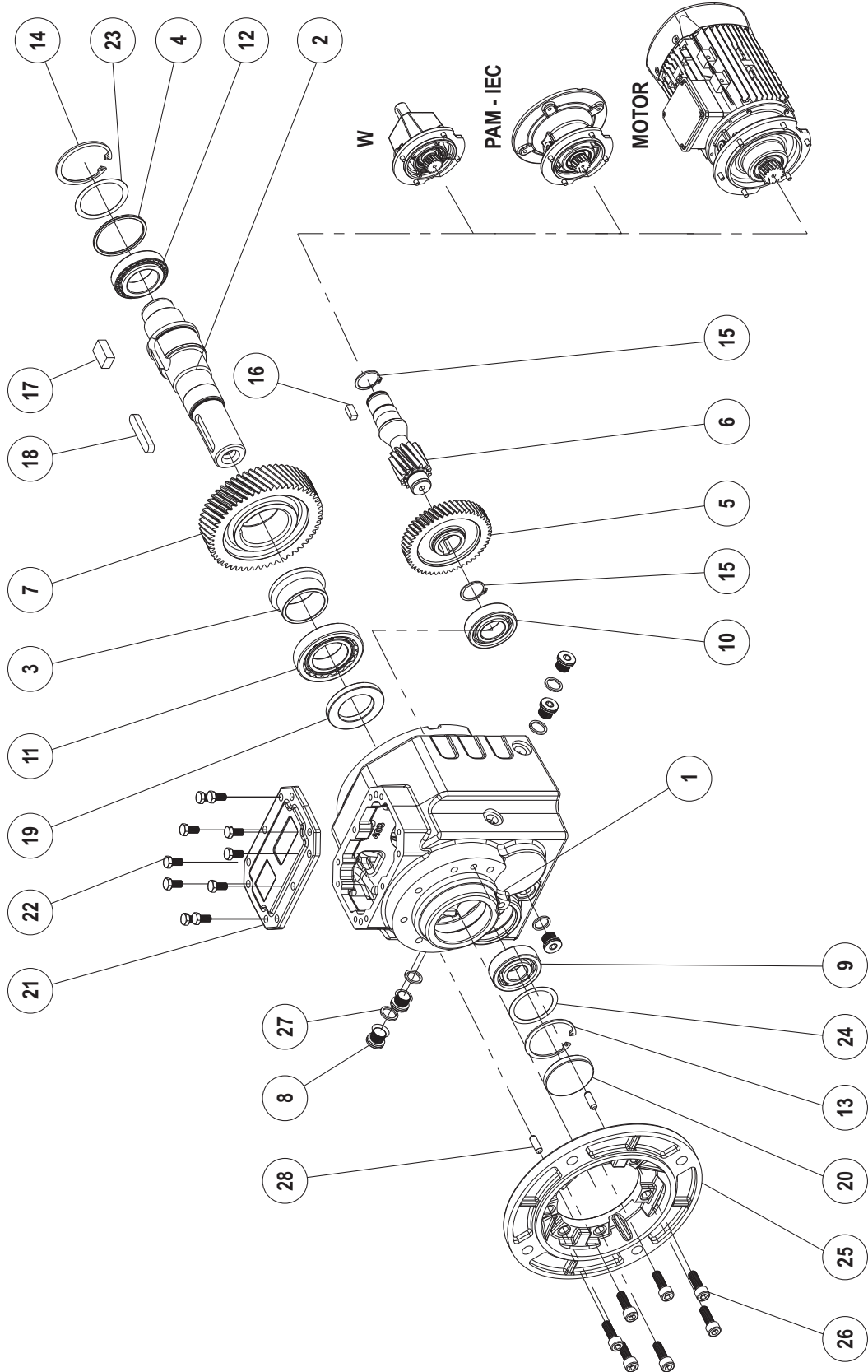

F 252...902

DE ALLGEMEINE TEILELISTE

EN GENERAL PART LIST

IT GENERALE ELENCO DELLE PARTI

FR GÉNÉRALE LA LISTE DES PIÈCES

ES LISTE DE PIEZAS EN GENERAL

01 Getriebegehäuse
02 Abtriebswelle
03 Distanzbuchse
04 Stützscheibe
05 Abtriebsrad
06 Ritzel Welle
07 Abtriebsrad
08 Ölstopfen
09 Kugellager
10 Kugellager
11 Kugellager
12 Kugellager
13 Sicherungsring
14 Sicherungsring
15 Sicherungsring
16 Passfeder
17 Passfeder
18 Passfeder
19 Wellendichtring
20 Verschlusskappe
21 Gehäusedeckel
22 Schraube
23 Scheibe
24 Scheibe
25 B5 Flansch
26 Schraube
27 Dichtung
28 Spannstift

Gear Case
Solid Shaft
Spacer
Washer
Driving Gear
Pinion Shaft
Driven Gear
Oil Plug
Bearing
Bearing
Bearing
Bearing
Circlip
Circlip
Circlip
Key
Key
Key
Shaft Seal
Locking Cap
Case Cover
Bolt
Shim
Shim
Shim
Flange B5
Bolt
Seal
Dowel Pin

Ingranaggi Box
Albero di uscita
Distanziatore
Rondella
Ingranaggio Conduttore
Pignone
Ingranaggio Condotta
Olio Tappo
Cuscinetto
Cuscinetto
Cuscinetto
Cuscinetto
Anello di sicurezza
Anello di sicurezza
Anello di sicurezza
Chiavetta
Chiavetta
Chiavetta
Tenuta Albero
Tappo di chiusura
Coperchiodella custodia
Bullone
Shim
Shim
Shim
Flangia B5
Bullone
Sigillo
Tassello Pin

01 Carter d'engrenage
02 Arbre de sortie
03 Douille entretoise
04 Rondelle support
05 Rove d'entrée
06 Arbre intermédiaire
07 Rove de sortie
08 Visde vidange
09 Roulement a billes
10 Roulement a billes
11 Roulement a billes
12 Roulement a billes
13 Circlip
14 Circlip
15 Circlip
16 Clavette
17 Clavette
18 Clavette
19 Bague d'értancheite
20 Bouchon
21 Couvercle de carter
22 Boulonner
23 Rondelle d'ajustage
24 Rondelle d'ajustage
25 B5 à bride
26 Boulonner
27 Joint
28 Goupille

La caja de engranajes
Eje de salida
Espaciador
El apoyo a disco
Engraneje conducido
Deleje del piñón
Engranaje conducido
Tapón
Rodamientode bolas
Rodamientode bolas
Rodamientode bolas
Rodamientode bolas
Anillo de seguridad
Anillo de seguridad
Anillo de seguridad
Clave
Clave
Clave
Sello del eje
Tapón de cierre
Tapá de la carcasa
Atornillar
Calce
Calce
Brida B5
Atornillar
Sellar
Pasador

DE ALLGEMEINE TEILELISTE

EN GENERAL PART LIST

IT GENERALE ELENCO DELLE PARTI

FR GÉNÉRALE LA LISTE DES PIÈCES

ES LISTE DE PIEZAS EN GENERAL

F 253...903

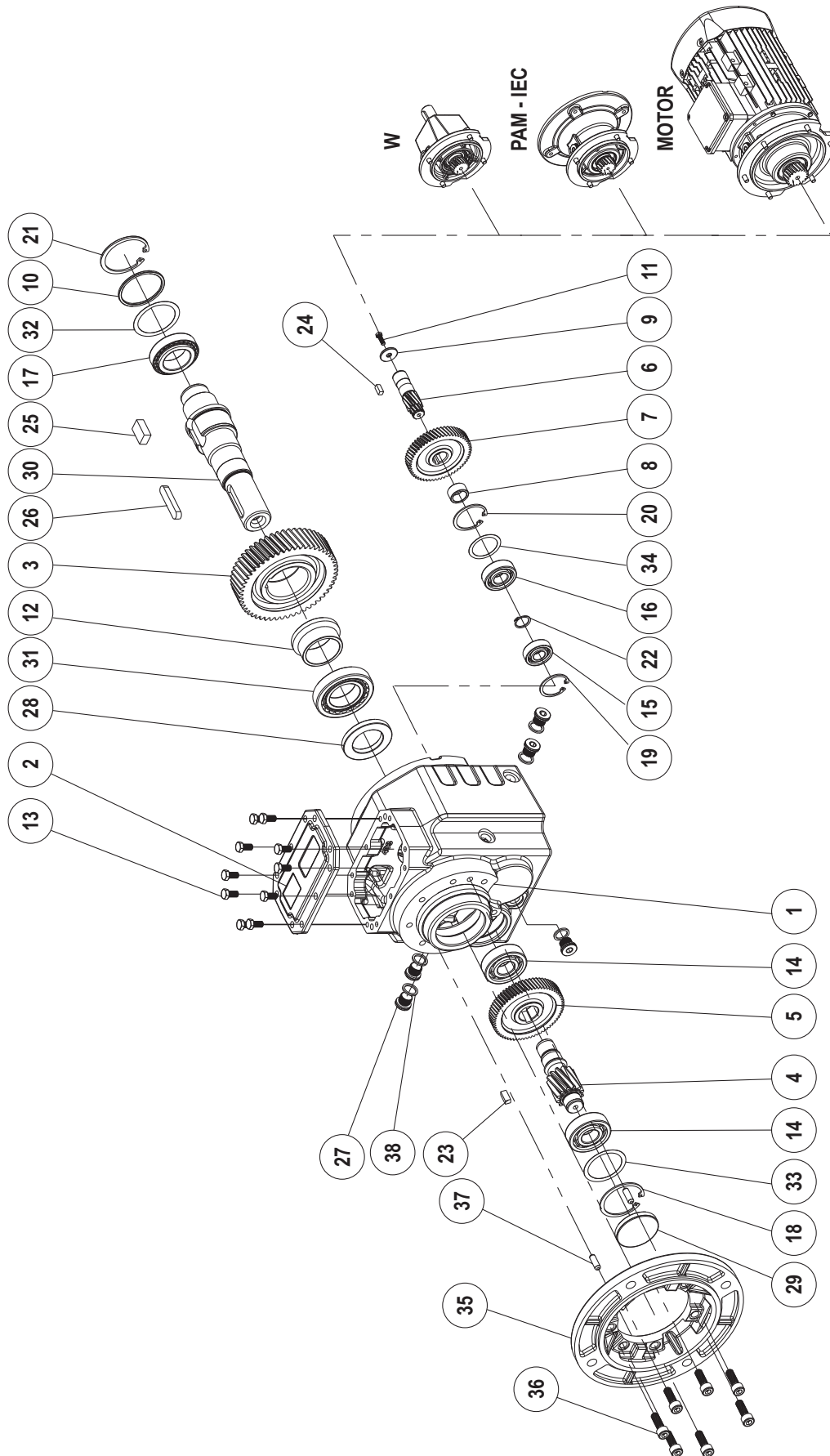

DE ALLGEMEINE TEILELISTE

EN GENERAL PART LIST

IT GENERALE ELENCO DELLE PARTI

FR GÉNÉRALE LA LISTE DES PIÈCES

ES LISTE DE PIEZAS EN GENERAL

01	Getriebegehäuse	Gear Case	Ingranaggi Box	Carter d'engrenage	La caja de engranajes
02	Gehäusedeckel	Case Cover	Coperchiodella custodia	Couvercle du carter	Tapá de la carcasa
03	Abtriebsrad	Driving Gear	Ingranaggio Conduttore	Rove d'entrée	Engranaje conducido
04	Ritzel welle	Pinion Shaft	Pignone	Arbre intermédiaire	Deleje del piñón
05	Abtriebsrad	Driven Gear	Ingranaggio condotto	Rove de sortie	Engranaje conducido
06	Pinion Gear	Pinion Gear	Pignone	Arbre intermédiaire	Deleje del piñón
07	Abtriebsrad	Driving Gear	Ingranaggio conduttore	Rove d'entrée	Engranaje conducido
08	Distanzbuchse	Spacer	Distanziatore	Doville entretoise	Espaciador
09	Stützscheibe	Washer	Rondella	Rondelle support	El apoyo a disco
10	Stützscheibe	Washer	Rondella	Rondelle support	El apoyo a disco
11	Schraube	Bolt	Bullone	Boulonner	Atornillar
12	Distanzbuchse	Spacer	Distanziatore	Doville entretoise	Espaciador
13	Schraube	Bolt	Bullone	Boulonner	Atornillar
14	Kugellager	Bearing	Cuscinetto	Roulement	Rodamiento de bolas
15	Kugellager	Bearing	Cuscinetto	Roulement	Rodamiento de bolas
16	Kugellager	Bearing	Cuscinetto	Roulement	Rodamiento de bolas
17	Kugellager	Bearing	Cuscinetto	Roulement	Rodamiento de bolas
18	Sicherungsring	Circlip	Anello di sicurezza	Circlip	Anillo de seguridad
19	Sicherungsring	Circlip	Anello di sicurezza	Circlip	Anillo de seguridad
20	Sicherungsring	Circlip	Anello di sicurezza	Circlip	Anillo de seguridad
21	Sicherungsring	Circlip	Anello di sicurezza	Circlip	Anillo de seguridad
22	Sicherungsring	Circlip	Anello di sicurezza	Circlip	Anillo de seguridad
23	Passfeder	Key	Chiavetta	Clavette	Clave
24	Passfeder	Key	Chiavetta	Clavette	Clave
25	Passfeder	Key	Chiavetta	Clavette	Clave
26	Passfeder	Key	Chiavetta	Clavette	Clave
27	Verschlussschraube	Oil Plug	Olio Tappo	Visde vidange	Tapón
28	Wellendichtring	Shaft Seal	Tenuta Albero	Bague d'étanchéité	Sello del eje
29	Verschlusskappe	Locking cap	Tappo di chiusura	Bouchon	Tapón de cierre
30	Abtriebswelle	Solid Shaft	Albero di uscita	Arbre de sortie	Eje de salida
31	Verschlussschraube	Bearing	Cuscinetto	Roulement a billes	Rodamiento de bolas
32	Scheibe	Shim	Shim	Rondelle d'ajustage	Calce
33	Scheibe	Shim	Shim	Rondelle d'ajustage	Calce
34	Scheibe	Shim	Shim	Rondelle d'ajustage	Calce
35	B5 Flansch	Flange B5	Flangia B5	Brida B5	Brida B5
36	Schraube	Bolt	Bullone	Boulonner	Atornillar
37	Pin	Dowel Pin	Pin	Pin	Pin
38	Dichtung	Seal	Sigillo	Joint	Sellar

DE ALLGEMEINE TEILELISTE

EN GENERAL PART LIST

IT GENERALE ELENCO DELLE PARTI

FR GÉNÉRALE LA LISTE DES PIÈCES

ES LISTE DE PIEZAS EN GENERAL

A/F 252...502 PAM
A/F 253...503 PAM

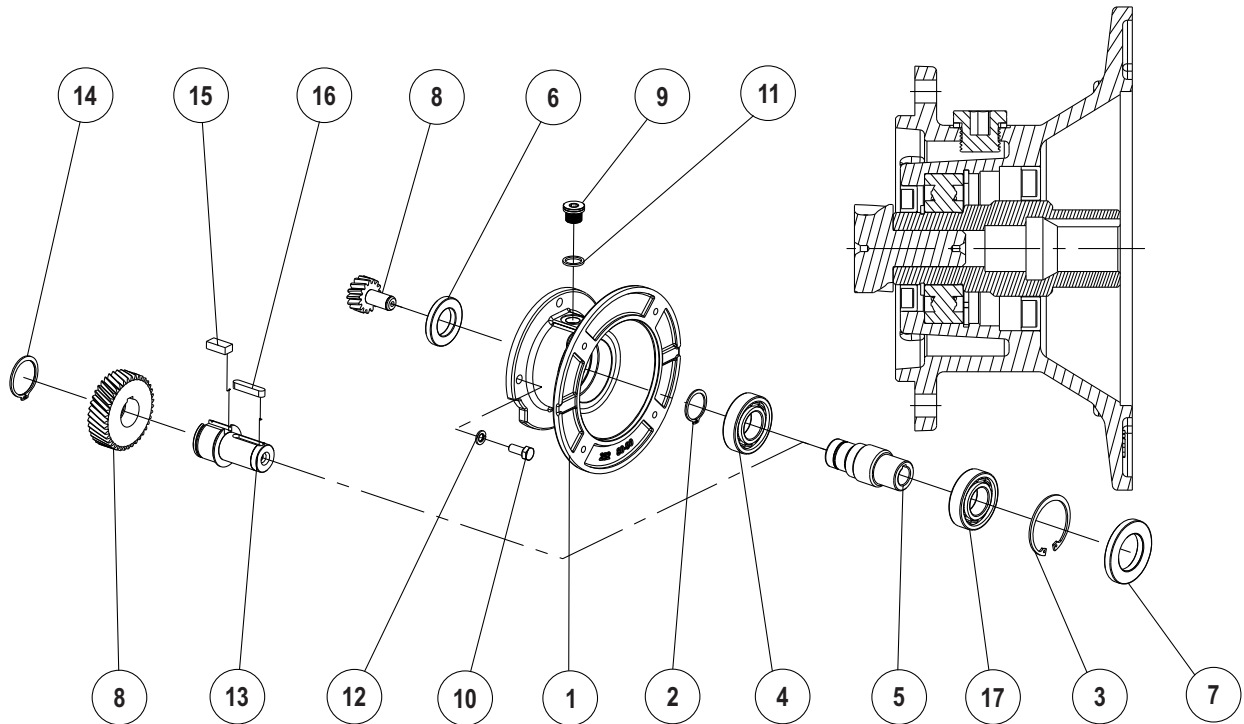

- 01 PAM Box
- 02 Sicherungsring
- 03 Sicherungsring
- 04 Kugellager
- 05 PAM Welle
- 06 Wellendichtring
- 07 Wellendichtring
- 08 Antriebsritzel
- 09 Verschlusschraube
- 10 Schraube
- 11 Dichtung
- 12 Federscheibe
- 13 Z1 Welle
- 14 Circlip
- 15 Passfeder
- 16 Passfeder
- 17 Kugellager

- PAM Case
- Circlip
- Circlip
- Bearing
- PAM Shaft
- Shaft Seal
- Shaft Seal
- Input Pinion
- Oil Plug
- Bolt
- Seal
- Spring Washer
- Z1 Shaft
- Circlip
- Key
- Key
- Bearing

- PAM Box
- Anello di sicurezza
- Anello di sicurezza
- Cuscinetto
- PAM Albero
- Tenuta Albero
- Tenuta Albero
- Ingresso Pignone
- Olio Tappo
- Bullone
- Sigillo
- Rondella elastica
- Z1 Albero
- Chiavetta
- Chiavetta
- Cuscinetto

- PAM Boite
- Circlip
- Circlip
- Roulement
- PAM Arbre
- Bague d'étancheite
- Bague d'étancheite
- Pignon d'entrée
- Visde vidange
- Boulonner
- Joint
- Rondella élastique
- Z1 Arbre
- Circlip
- Clavette
- Clavette
- Roulement

- PAM Caja
- Anillo de seguridad
- Anillo de seguridad
- Rodamiento de bolas
- PAM Eje
- Sello del eje
- Sello del eje
- Piñón de entrada
- Tapón
- Atornillor
- Sellar
- Arandela
- Z1 Eje
- Anillo de seguridad
- Clave
- Clave
- Rodamiento de bolas

DE ALLGEMEINE TEILELISTE

EN GENERAL PART LIST

IT GENERALE ELENCO DELLE PARTI

FR GÉNÉRALE LA LISTE DES PIÈCES

ES LISTE DE PIEZAS EN GENERAL

A/F 602...902 PAM
A/F 603...903 PAM

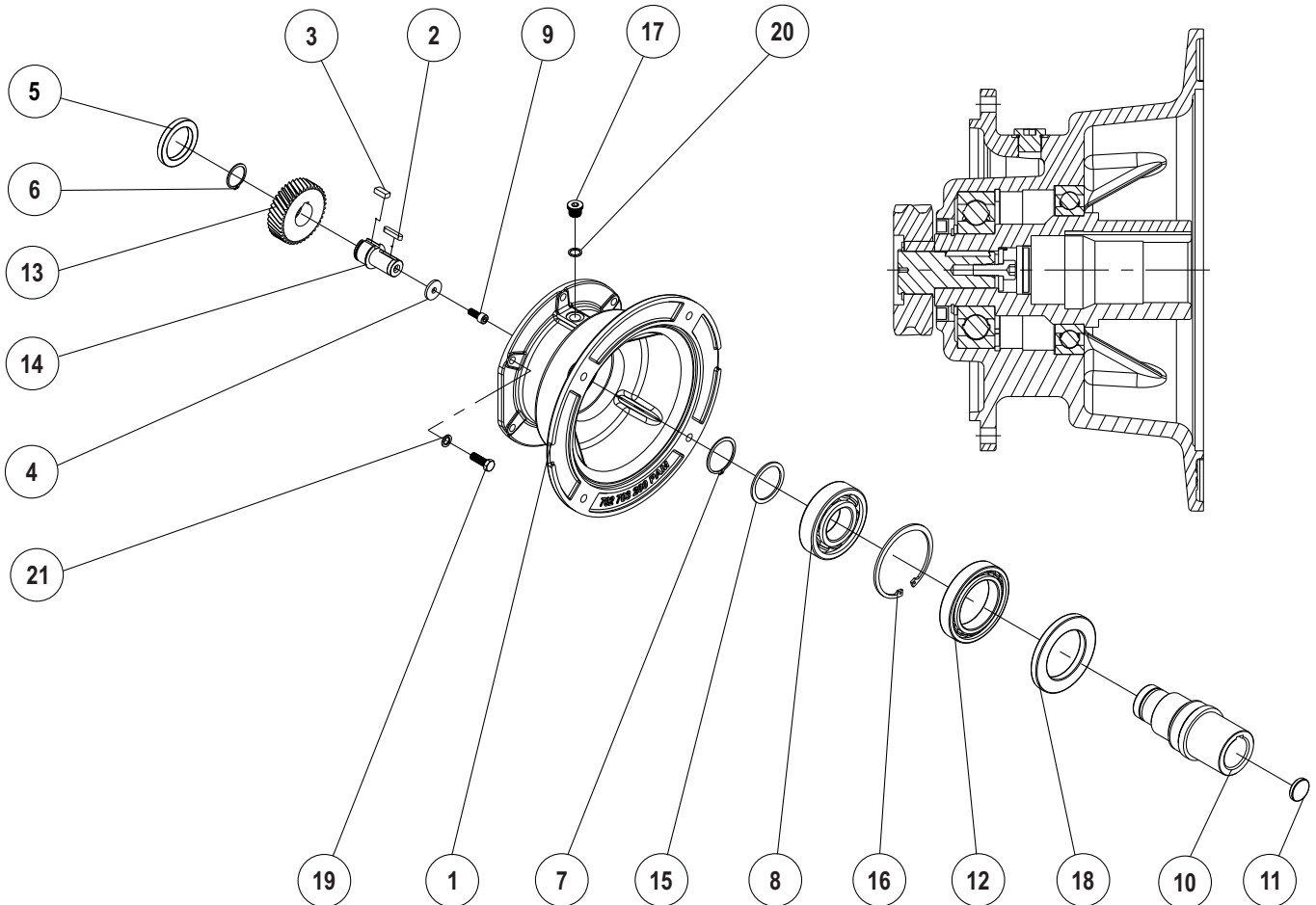

01 PAM Box	PAM Case	PAM Box	PAM Boite	PAM Caja
02 Passfeder	Key	Chiavetta	Clavette	Clave
03 Passfeder	Key	Chiavetta	Clavette	Clave
04 Stützscheibe	Washer	Rondella	Rondelle support	Al apoyo a disco
05 Wellendichtring	Shaft Seal	Tenuta Albero	Bagua d'étancheite	Sello del eje
06 Sicherungsring	Circlip	Anello di sicurezza	Circlip	Anillo de seguridad
07 Sicherungsring	Circlip	Anello di sicurezza	Circlip	Anillo de seguridad
08 Kugellager	Bearing	Cuscinetto	Roulement	Rodamiento de bolas
09 Schraube	Bolt	Bullone	Boulonner	Atornillar
10 PAM Welle	PAM Shaft	PAM Albero	PAM Arbre	PAM Eje
11 Verschlusskappe	Locking cap	Tappo di chiusura	Bouchon	Tapón de cierre
12 Kugellager	Bearing	Cuscinetto	Roulement	Rodamiento de bolas
13 Antriebsritzel	Input Pinion	Ingresso Pignone	Pignon d'entrée	Piñón de entrada
14 Z1 Welle	Z1 Shaft	Z1 Albero	Z1 Arbre	Z1 Eje
15 Scheibe	Shim	Shim	Rondelle d'ajustage	Rondelle d'ajustage
16 Sicherungsring	Circlip	Anello di sicurezza	Circlip	Anillo de seguridad
17 Verschlusschraube	Oil Plug	Olio Tappo	Visde vidange	Tapón
18 Wellendichtring	Shaft Seal	Tenuta Albero	Bague d'étancheite	Sello del eje
19 Schraube	Bolt	Bullone	Boulonner	Atornillar
20 Dichtung	Seal	Sigillo	Joint	Sellar
21 Federscheibe	Spring Washer	Rondella Elastica	Rondella élastique	Arandela

DE ALLGEMEINE TEILELISTE

EN GENERAL PART LIST

IT GENERALE ELENCO DELLE PARTI

FR GÉNÉRALE LA LISTE DES PIÈCES

ES LISTE DE PIEZAS EN GENERAL

A/F 252...253 / 902...903 W

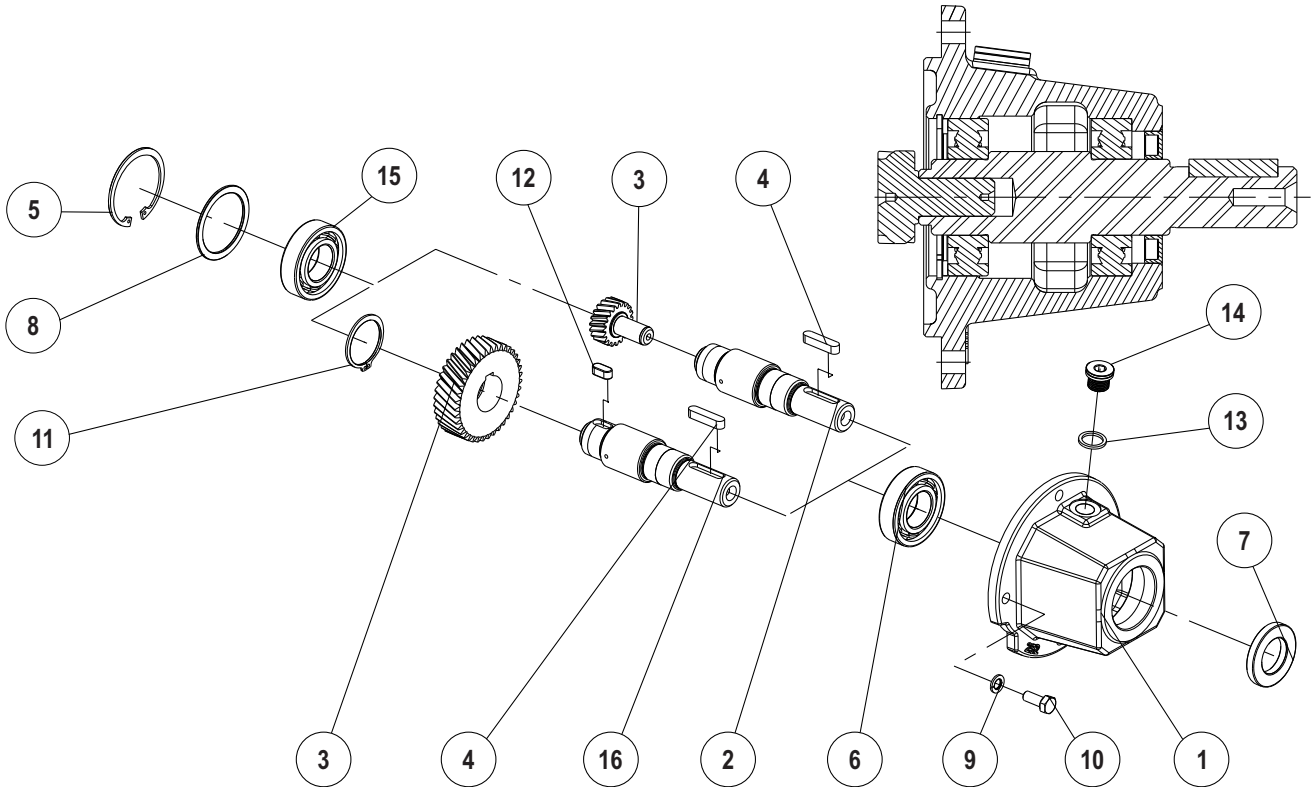

- 1 W Box
- 2 W Welle mit Getriebe
- 3 Antriebsritzel
- 4 Passfeder
- 5 Sicherungsring
- 6 Kugellager
- 7 Wellendichtring
- 8 Scheibe
- 9 Federscheibe
- 10 Schraube
- 11 Sicherungsring
- 12 Passfeder
- 13 Dichtung
- 14 Verschlusschraube
- 15 Kugellager
- 16 W Welle

- W Case
- W Shaft with gear
- Input Pinion
- Key
- Circlip
- Bearing
- Shaft Seal
- Shim
- Spring Washer
- Bolt
- Circlip
- Key
- Seal
- Oil Plug
- Bearing
- W Shaft

- W Box
- W Albero con ingranaggio
- Ingresso Pignone
- Chiavetta
- Anello di sicurezza
- Cuscinetto
- Tenuta Albero
- Shim
- Rondella elastica
- Bullone
- Anello di sicurezza
- Chiavetta
- Sigillo
- Olio Tappo
- Cuscinetto
- W Albero

- W Boite
- W Arbre avec des engins
- Pignon d'entrée
- Clavette
- Circlip
- Roulement
- Bague d'étanchéité
- Rondelle d'ajustage
- Rondelle élastique
- Boulonner
- Circlip
- Clavette
- Sigillo
- Visde vidange
- Roulement
- W Arbre

- W Caja
- W Eje col el engranaje
- Piñón de entrada
- Clave
- Anillo de seguridad
- Rodamiento de bolas
- Sello del eje
- Rondelle d'ajustage
- Arandela
- Atornillar
- Anillo de seguridad
- Clave
- Sellar
- Tapón
- Rodamiento de bolas
- W Eje



A large area of the page containing numerous horizontal dotted lines, serving as a template for writing or drawing.

ELECTRICAL CHARACTERISTICS AT 50 Hz

Motor Type	Housing Type	Rated Values					Starting Values					Breakdown Torque Ratio Mk/Mn	Efficiency*			Cos φ	J kgm ²	Weight (B3) kg	Sound Pressure Level dBA**
		Power		Speed	Current	Torque	Current		Torque		η%		4/4	3/4	2/4				
		kW	HP	d/d	A	Nm	I _A / A _N	Δ	M _A / M _N	Δ	4/4								
2pole3000d/d																			
220/380V	Q3E80M2C	Aluminum	0,75	1,0	2880	1,7	2,5	7,4	-	4,0	-	4,8	80,7	79,1	77,4	0,86	0,00109	12,2	58
	Q3E80M2D	Aluminum	1,1	1,5	2895	2,4	3,7	8,4	-	4,9	-	5,1	82,7	82,1	78,9	0,84	0,00150	13	58
	Q3E90L2C	Aluminum	1,5	2,0	2910	3,2	4,9	8,9	-	4,2	-	4,9	84,2	84,7	82,3	0,86	0,00182	17,5	62
	Q3E90L2D	Aluminum	2,2	3,0	2900	4,6	7,2	8,6	-	4,6	-	4,0	85,9	87,0	85,5	0,84	0,00182	18	62
	Q3E100L2D	Aluminum	3,0	4,0	2920	5,6	9,8	9,8	-	4,1	-	4,4	87,1	86,9	84,5	0,89	0,00335	25	64
380/660V	Q3E112M2C	Aluminum	4,0	5,5	2915	7,8	13,2	3,2	9,7	1,3	3,8	5,1	88,1	87,9	85,7	0,87	0,00489	31	67
	Q3E132S2C	Aluminum	5,5	7,5	2900	10,4	18,0	3,6	10,8	1,0	3,0	3,5	89,2	88,9	86,7	0,91	0,01410	48	70
	Q3E132M2A	Aluminum	7,5	10,0	2930	13,7	24,5	3,2	9,7	1,3	3,8	4,4	90,1	90,3	88,9	0,91	0,01596	51	70
	Q3E160L2A	Aluminum	11,0	15,0	2940	19,8	35,9	2,9	8,8	1,0	3,0	5,1	91,2	91,4	90,3	0,93	0,03317	77	71
	Q3E160L2C	Aluminum	15,0	20,0	2945	26,7	48,8	3,6	10,8	1,1	3,2	3,9	91,9	91,0	90,3	0,93	0,04075	91	71
	Q3E160L2D	Aluminum	18,5	25,0	2940	33,4	60,0	2,9	8,8	1,3	3,8	4,1	92,4	92,0	90,9	0,91	0,04075	101	71
	Q3E180M2A	Aluminum	22,0	30,0	2955	38,7	71,3	3,5	10,5	1,1	3,2	3,2	92,7	92,9	91,7	0,93	0,06193	139	77
	Q3E200L2C	Aluminum	30,0	40,0	2950	52,9	97,4	3,0	9,1	0,8	2,4	3,5	93,3	93,8	93,4	0,93	0,11917	167	80
	Q3E200L2D	Aluminum	37,0	50,0	2950	65,2	119,5	3,2	9,7	0,9	2,7	3,5	93,7	94,1	93,8	0,92	0,15010	179	80
	Q3E225M2C	Aluminum	45,0	60,0	2965	80,3	145,2	2,7	8,0	0,8	2,4	3,4	94,0	94,0	93,2	0,91	0,23505	249	81
	Q3EP250M2C	Cast Iron	55,0	75,0	2980	95,9	178,5	2,1	6,4	0,7	2,1	3,1	94,3	94,0	92,6	0,91	0,48707	488	82
	Q3EP280M2C	Cast Iron	75,0	100,0	2975	125,4	240,8	2,7	8,0	0,6	1,9	4,0	94,7	94,0	92,7	0,92	0,54033	585	84
Q3EP280M2D	Cast Iron	90,0	125,0	2975	151,3	289,4	2,7	8,0	0,7	2,1	4,9	95,0	94,2	92,7	0,93	0,64510	587	84	
400/690V	Q3EP315S2C	Cast Iron	110,0	127,0	2.983	187	358	2,4	7,2	0,6	1,7	2,6	95,2	95,2	94,0	0,89	2,19900	963	83
	Q3EP315M2B	Cast Iron	132,0	152,0	2.983	224	418	2,5	7,5	0,6	1,8	2,6	95,4	95,4	94,4	0,89	2,37790	1.007	83
	Q3EP315L2A	Cast Iron	160,0	184,0	2.983	271	513	2,5	7,5	0,6	1,8	2,6	95,6	95,6	94,4	0,89	2,62170	1.065	83
	Q3EP315L2C	Cast Iron	200,0	230,0	2.983	339	641	2,5	7,5	0,6	1,9	2,6	95,8	95,8	94,9	0,89	2,90860	1.180	83
	Q3EP355M2C	Cast Iron	250,0	280,0	2.983	419	800	2,4	7,3	0,6	1,7	2,5	95,8	95,8	94,7	0,90	3,81300	1.612	91
	Q3EP355L2B	Cast Iron	315,0	353,0	2.984	527	1.008	2,4	7,3	0,6	1,8	2,5	95,8	95,7	94,4	0,90	4,52000	1.771	91
	Q3EP355L2C	Cast Iron	355,0	398,0	2.981	594	1.137	2,6	7,9	0,7	2,2	2,5	95,8	95,8	95,0	0,90	5,58000	2.002	91
4pole1500d/d																			
220/380V	Q3E80M4D	Aluminum	0,75	1,0	1430	1,8	5,0	6,1	-	3,0	-	3,1	82,5	81,2	78,0	0,77	0,00268	12	49
	Q3E90L4C	Aluminum	1,1	1,5	1440	2,5	7,4	7,5	-	2,9	-	3,3	84,1	84,1	81,3	0,80	0,00365	18	54
	Q3E90L4D	Aluminum	1,5	2,0	1440	3,5	10,0	7,9	-	3,2	-	3,6	85,3	84,9	82,0	0,76	0,00365	18	55
	Q3E100L4C	Aluminum	2,2	3,0	1445	5,1	14,6	7,6	-	3,7	-	4,0	86,7	84,4	82,0	0,78	0,00545	26	56
	Q3E100L4D	Aluminum	3,0	4,0	1435	7,1	19,9	8,2	-	3,8	-	4,1	87,7	87,3	85,5	0,73	0,00581	26	56
380/660V	Q3E112M4D	Aluminum	4,0	5,5	1445	8,3	26,3	2,8	8,3	1,0	3,0	4,0	88,6	87,6	85,8	0,83	0,01123	31	58
	Q3E132M4B	Aluminum	5,5	7,5	1465	11,4	36,2	2,3	6,8	1,1	3,2	3,9	89,6	89,0	86,8	0,80	0,02763	54	61
	Q3E132M4C	Aluminum	7,5	10,0	1450	15,8	49,4	2,5	7,4	1,0	3,0	4,1	90,4	89,3	87,4	0,82	0,02980	57	61
	Q3E160L4A	Aluminum	11,0	15,0	1470	23,0	71,9	2,4	7,1	1,0	3,0	3,6	91,4	90,7	89,4	0,81	0,06922	90	63
	Q3E160L4B	Aluminum	15,0	20,0	1465	30,8	98,0	2,7	8,0	0,9	2,6	3,4	92,1	91,7	90,7	0,82	0,07991	107	63
	Q3E180M4B	Aluminum	18,5	25,0	1470	35,3	120,7	2,8	8,3	0,8	2,4	3,1	92,6	92,5	92,2	0,86	0,11220	148	69
	Q3E180L4B	Aluminum	22,0	30,0	1475	42,0	142,4	2,7	8,0	0,8	2,4	2,5	93,0	93,0	93,0	0,86	0,12773	157	69
	Q3E200L4D	Aluminum	30,0	40,0	1480	54,3	193,6	2,4	7,1	0,7	2,2	2,5	93,6	93,6	93,7	0,86	0,26448	183	70
	Q3E225M4D	Aluminum	37,0	50,0	1485	77,8	239,6	2,8	8,3	0,9	2,7	3,3	93,9	92,6	90,6	0,81	0,36429	280	71
	Q3E225M4DE	Aluminum	45,0	60,0	1480	84,3	289,9	2,9	8,6	0,9	2,7	3,3	94,2	93,1	91,6	0,85	0,43513	282	71
	Q3EP250M4E	Cast Iron	55,0	75,0	1450	100,0	356,1	2,6	7,7	0,9	2,7	3,2	94,6	94,0	92,8	0,87	0,90782	506	72
	Q3EP280M4C	Cast Iron	75,0	100,0	1485	141,7	482,0	2,5	7,4	0,9	2,7	2,9	95,0	94,7	93,5	0,84	1,06114	624	73
Q3EP280M4D	Cast Iron	90,0	125,0	1485	163,5	584,2	2,5	7,4	0,9	2,7	2,9	95,2	94,5	93,7	0,86	1,14768	653	73	
400/690V	Q3EP315S4C	Cast Iron	110,0	127,0	1.489	194	705	2,5	7,5	0,7	2,0	2,5	95,4	95,4	94,7	0,86	3,46500	867	70
	Q3EP315M4B	Cast Iron	132,0	152,0	1.489	232	846	2,5	7,6	0,7	2,1	2,5	95,6	95,6	95,0	0,86	3,96600	993	70
	Q3EP315L4A	Cast Iron	160,0	184,0	1.489	274	1.026	2,5	7,6	0,7	2,2	2,5	95,8	95,8	95,4	0,88	4,88320	1.165	70
	Q3EP315L4C	Cast Iron	200,0	230,0	1.489	346	1.282	2,7	8,2	0,7	2,2	2,5	96,0	96,0	95,5	0,87	5,23440	1.223	70
	Q3EP355M4C	Cast Iron	250,0	280,0	1.491	422	1.601	2,5	7,5	0,6	1,9	2,4	96,0	96,0	95,5	0,89	9,30600	1.692	82
	Q3EP355L4B	Cast Iron	315,0	353,0	1.491	532	2.017	2,5	7,5	0,6	1,9	2,4	96,0	96,0	95,5	0,89	10,06700	1.879	82
	Q3EP355L4C	Cast Iron	355,0	398,0	1.491	600	2.273	2,5	7,5	0,7	2,0	2,3	96,0	96,0	95,5	0,89	11,90000	1.953	82

ELECTRICAL CHARACTERISTICS AT 50 Hz

Motor Type	Housing Type	Rated Values						Starting Values				Breakdown Torque Ratio Mk/Mn	Efficiency*			Cos φ	J kgm ²	Weight (B3) kg	Sound Pressure Level dBA**
		Power		Speed	Current	Torque	Current		Torque										
		kW	HP	d/d	A	Nm	I _A / A _N	Δ	M _A / M _N	Δ									
6pole1000d/d																			
220/380V	Q3E90L6C	Aluminum	0,75	1,0	940	2,2	7,6	4,0	-	2,3	-	2,5	78,9	77,7	76,1	0,65	0,00365	18	54
	Q3E90L6D	Aluminum	1,1	1,5	940	3,1	11,2	4,2	-	2,3	-	2,6	81,0	80,5	79,9	0,66	0,00451	20	55
	Q3E100L6D	Aluminum	1,5	2,0	940	3,9	15,2	4,5	-	2,3	-	2,7	82,5	81,9	79,0	0,68	0,00570	26	56
	Q3E112M6D	Aluminum	2,2	3,0	950	5,4	22,0	4,7	-	2,4	-	2,7	84,3	83,7	80,7	0,73	0,01107	32	58
380/660V	Q3E132M6B	Aluminum	3,0	4,0	960	7,5	29,7	1,7	5,2	0,6	1,7	2,3	85,6	85,2	82,8	0,70	0,02709	58,5	61
	Q3E132M6C	Aluminum	4,0	5,5	955	9,5	39,8	1,8	5,3	0,6	1,9	2,3	86,8	85,7	82,8	0,74	0,02921	67	61
	Q3E132M6D	Aluminum	5,5	7,5	950	12,7	55,0	1,7	5,0	0,6	1,8	2,3	88,0	87,6	85,3	0,75	0,03347	76	61
	Q3E160L6C	Aluminum	7,5	10,0	970	17,7	74,2	1,8	5,5	0,6	1,9	2,7	89,1	89,0	88,0	0,72	0,07663	96	63
	Q3E160L6D	Aluminum	11,0	15,0	955	25,3	109,4	1,8	5,5	0,6	1,9	2,7	90,3	90,1	89,3	0,75	0,08129	100,5	63
	Q3E180L6B	Aluminum	15,0	20,0	978	32,2	146,2	2,0	5,9	0,6	1,8	2,6	91,2	90,9	88,7	0,79	0,22951	155	69
	Q3E200L6C	Aluminum	18,5	25,0	975	37,7	180,3	1,8	5,5	0,5	1,6	2,4	91,7	91,5	90,9	0,82	0,31281	165	70
	Q3E200L6D	Aluminum	22,0	30,0	975	44,5	214,4	1,8	5,5	0,5	1,6	2,4	92,2	92,0	91,4	0,82	0,33078	170	70
	Q3E225M6C	Aluminum	30,0	40,0	970	62,1	293,8	1,8	5,4	0,5	1,6	2,3	92,9	92,8	91,8	0,79	0,52901	237,5	71

* According to IEC 60034-2-1

** The sound pressure measurement are taken 1m away from the motor.

** Tolerance + 3 dBA

DIMENSIONS - B3

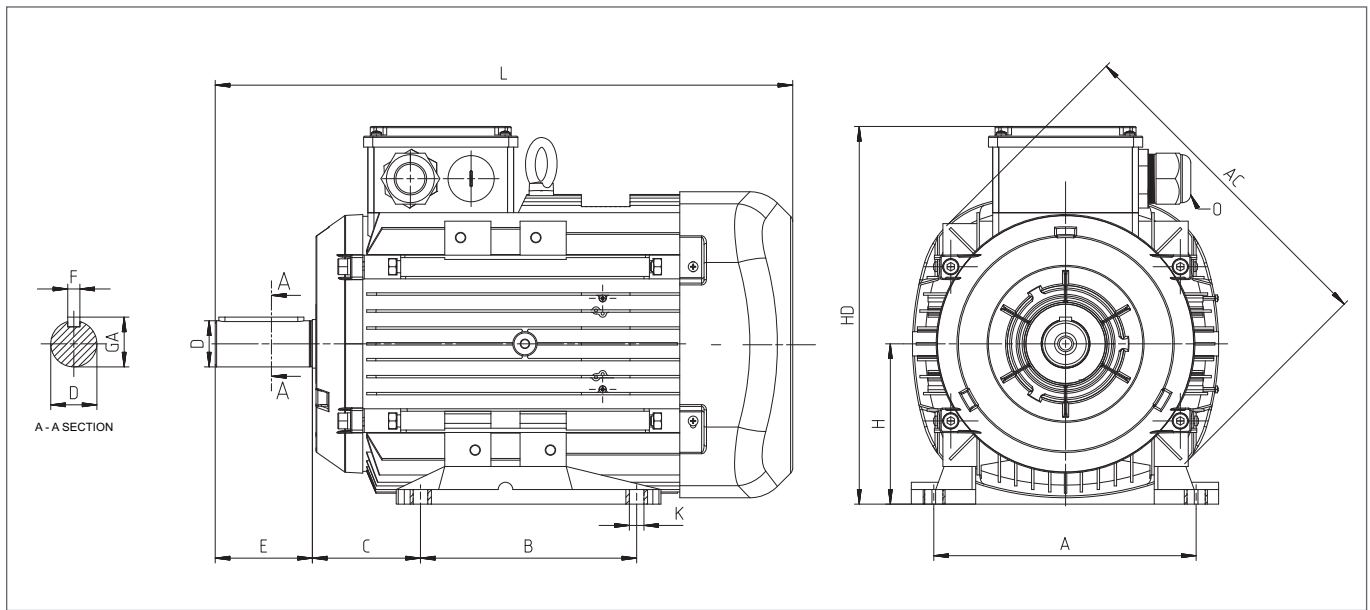

Power (kW)	Number of Poles	Motor Type	Housing Type	Main Dimensions			Foot Mounted Motors						Shaft				Bearing		Seal	
				AC	L	O	B	A	H	HD	K	C	D ⁽¹⁾	E	GA	F ⁽²⁾	Drive Side	Non Drive Side	Drive Side	Non Drive Side
0,75	2	Q3E80M2C	Aluminum	158	283,5	1*M20	100	125	80	195	10	50	19	40	21,5	6	6204-2Z	6204-2Z	20*30*7	20*30*7
	4	Q3E80M4D	Aluminum	158	283,5	1*M20	100	125	80	195	10	50	19	40	21,5	6	6204-2Z	6204-2Z	20*30*7	20*30*7
	6	Q3E90L6C	Aluminum	193	316,5	1*M25	125	140	90	222	10	56	24	50	27	8	6305-2Z	6205-2Z	25*40*7	25*40*7
1,1	2	Q3E80M2D	Aluminum	158	283,5	1*M20	100	125	80	195	10	50	19	40	21,5	6	6204-2Z	6204-2Z	20*30*7	20*30*7
	4	Q3E90L4C	Aluminum	193	316,5	1*M25	100	140	90	222	10	56	24	50	27	8	6305-2Z	6205-2Z	25*40*7	25*40*7
	6	Q3E90L6D	Aluminum	193	344,5	1*M25	125	140	90	222	10	56	24	50	27	8	6305-2Z	6205-2Z	25*40*7	25*40*7
1,5	2	Q3E90L2C	Aluminum	193	316,5	1*M25	100	140	90	222	10	56	24	50	27	8	6305-2Z	6205-2Z	25*40*7	25*40*7
	4	Q3E90L4D	Aluminum	193	344,5	1*M25	125	140	90	222	10	56	24	50	27	8	6305-2Z	6205-2Z	25*40*7	25*40*7
	6	Q3E100L6D	Aluminum	217	352,0	1*M25	140	160	100	241	12	63	28	60	31	8	6306-2Z	6205-2Z	30*47*7	25*47*7
2,2	2	Q3E90L2D	Aluminum	193	316,5	1*M25	125	140	90	222	10	56	24	50	27	8	6305-2Z	6205-2Z	25*40*7	25*40*7
	4	Q3E100L4C	Aluminum	217	352,0	1*M25	140	160	100	241	12	63	28	60	31	8	6306-2Z	6205-2Z	30*47*7	25*40*7
	6	Q3E112M6D	Aluminum	232	395,5	2*M25	140	190	112	261	12	70	28	60	31	8	6306-2Z	6206-2Z	30*47*7	30*47*7
3,0	2	Q3E100L2C	Aluminum	217	352,0	1*M25	140	160	100	241	12	63	28	60	31	8	6306-2Z	6205-2Z	30*47*7	25*40*7
	4	Q3E100L4D	Aluminum	217	377,0	1*M25	140	160	100	241	12	63	28	60	31	8	6306-2Z	6205-2Z	30*47*7	25*40*7
	6	Q3E132M6B	Aluminum	260	481,0	2*M32	178	216	132	323	12	89	38	80	41	10	6208-2Z	6208-2Z	40*62*10	40*62*10
4,0	2	Q3E112M2C	Aluminum	232	395,5	2*M25	140	190	112	261	12	70	28	60	31	8	6306-2Z	6206-2Z	30*47*7	30*47*7
	4	Q3E112M4C	Aluminum	232	395,5	2*M25	140	190	112	261	12	70	28	60	31	8	6306-2Z	6206-2Z	30*47*7	30*47*7
	6	Q3E132M6C	Aluminum	260	481,0	2*M32	178	216	132	323	12	89	38	80	41	10	6208-2Z	6208-2Z	40*62*10	40*62*10
5,5	2	Q3E132S2C	Aluminum	279	440,5	2*M32	140	216	132	314	12	89	38	80	41	10	6208-2Z	6208-2Z	40*62*10	40*62*10
	4	Q3E132M4B	Aluminum	279	475,5	2*M32	140	216	132	314	12	89	38	80	41	10	6208-2Z	6208-2Z	40*62*10	40*62*10
	6	Q3E132M6D	Aluminum	260	481,0	2*M32	178	216	132	323	12	89	38	80	41	10	6208-2Z	6208-2Z	40*62*10	40*62*10
7,5	2	Q3E132M2A	Aluminum	279	475,5	2*M32	140	216	132	314	12	89	38	80	41	10	6208-2Z	6208-2Z	40*62*10	40*62*10
	4	Q3E132M4C	Aluminum	279	475,5	2*M32	178	216	132	314	12	89	38	80	41	10	6208-2Z	6208-2Z	40*62*10	40*62*10
	6	Q3E160L6C	Aluminum	302	576,0	2*M32	254	254	160	360	15	108	42	110	45	12	6309-2Z	6209-2Z	45*72*10	45*72*10
11,0	2	Q3E160L2A	Aluminum	302	576,0	2*M32	254	254	160	360	15	108	42	110	45	12	6309-2Z	6209-2Z	45*72*10	45*72*10
	4	Q3E160L4A	Aluminum	302	576,0	2*M32	254	254	160	360	15	108	42	110	45	12	6309-2Z	6209-2Z	45*72*10	45*72*10
	6	Q3E160L6D	Aluminum	302	576,0	2*M32	254	254	160	360	15	108	42	110	45	12	6309-2Z	6209-2Z	45*72*10	45*72*10
15,5	2	Q3E160L2C	Aluminum	302	576,0	2*M32	254	254	160	360	15	108	42	110	45	12	6309-2Z	6209-2Z	45*72*10	45*72*10
	4	Q3E160L4B	Aluminum	302	576,0	2*M32	254	254	160	360	15	108	42	110	45	12	6309-2Z	6209-2Z	45*72*10	45*72*10
	6	Q3E180L6B	Aluminum	347	689,0	2*M40	279	279	180	452	15	121	48	110	51,5	14	6310-2Z	6310-2Z	50*80*10	50*80*10
18,5	2	Q3E160L2C	Aluminum	302	576,0	2*M32	254	254	160	360	15	108	42	110	45	12	6309-2Z	6209-2Z	45*72*10	45*72*10
	4	Q3E180M4B	Aluminum	370	629,0	2*M40	241	279	180	428	15	121	48	110	51,5	14	6310-2Z	6310-2Z	50*80*10	50*80*10
	6	Q3E200L6C	Aluminum	415	665,0	2*M50	305	318	200	461	19	133	55	110	59	16	6312-2Z	6312-2Z	60*90*10	60*90*10

DIMENSIONS - B3

Power (kW)	Number of Poles	Motor Type	Housing Type	Main Dimensions			Foot Mounted Motors						Shaft				Bearing		Seal	
				AC	L	O	B	A	H	HD	K	C	D ⁽¹⁾	E	GA	F ⁽²⁾	Drive Side	Non Drive Side	Drive Side	Non Drive Side
22,0	2	Q3E160L2D	Aluminum	302	576,0	2*M32	210	254	160	360	15	108	42	110	45	12	6309-2Z	6209-2Z	45*72*10	45*72*10
	2	Q3E180M2A	Aluminum	370	629,0	2*M40	241	279	180	428	15	121	48	110	51,5	14	6310-2Z	6310-2Z	50*80*10	50*80*10
	4	Q3E180L4B	Aluminum	370	629,0	2*M40	279	279	180	428	15	121	48	110	51,5	14	6310-2Z	6310-2Z	50*80*10	50*80*10
	6	Q3E200L6D	Aluminum	415	665,0	2*M50	305	318	200	461	19	133	55	110	59	16	6312-2Z	6312-2Z	60*90*10	60*90*10
30,0	2	Q3E200L2B	Aluminum	415	665,0	2*M50	305	318	200	461	19	133	55	110	59	16	6312-2Z	6310-2Z	60*90*10	50*80*10
	4	Q3E200L4D	Aluminum	415	665,0	2*M50	311	318	200	461	19	133	55	110	59	16	6312-2Z	6310-2Z	60*90*10	50*80*10
	6	Q3E225M6C	Aluminum	456	765,0	2*M40	311	356	225	485	19	149	60	140	64	18	6313-2Z	6313-2Z	65*100*13	65*100*13
37,0	2	Q3E200L2C	Aluminum	415	665,0	2*M50	305	318	200	461	19	133	55	110	59	16	6312-2Z	6310-2Z	60*90*10	50*80*10
	4	Q3E225M4C	Aluminum	456	765,0	2*M50	286	356	225	504	19	149	60	140	64	18	6313-2Z	6313-2Z	65*100*13	65*100*13
45,0	2	Q3E225M2B	Aluminum	456	735,0	2*M50	311	356	225	504	19	149	55	110	59	16	6313-2Z	6313-2Z	65*100*13	65*100*13
	4	Q3E225M4D	Aluminum	456	765,0	2*M50	311	356	225	504	19	149	60	140	64	18	6313-2Z	6313-2Z	65*100*13	65*100*13
55,0	2	Q3EP250M2C	Cast Iron	527	886,0	2*M50	349	406	250	615	24	168	60	140	64	18	6316	6316	80*100*10	80*100*10
	4	Q3EP250M4E	Cast Iron	527	886,0	2*M50	349	406	250	615	24	168	65	140	69	18	6316	6316	80*100*10	80*100*10
75,0	2	Q3EP280M2C	Cast Iron	527	1025,0	2*M50	419	457	280	647	24	190	65	140	69	18	6316	6316	80*100*10	80*100*10
	4	Q3EP280M4C	Cast Iron	527	1025,0	2*M50	419	457	280	647	24	190	75	140	80	20	6316	6316	80*100*10	80*100*10
90,0	2	Q3EP280M2D	Cast Iron	527	1025,0	2*M50	419	457	280	647	24	190	65	140	69	18	6316	6316	80*100*10	80*100*10
	4	Q3EP280M4D	Cast Iron	527	1025,0	2*M50	419	457	280	647	24	190	75	140	80	20	6316	6316	80*100*10	80*100*10
110,0	2	Q3EP315S2C	Cast Iron	652	1176,0	2*M63	406	508	315	833	28	216	65	140	69	18	6316	6316	80*100*5.5	80*100*5.5
	4	Q3EP315S4C	Cast Iron	652	1206,0	2*M63	406	508	315	833	28	216	80	170	85	22	6319	6319	95*115*5.5	95*115*5.5
132,0	2	Q3EP315M2B	Cast Iron	652	1176,0	2*M63	457	508	315	833	28	216	65	140	69	18	6316	6316	80*100*5.5	80*100*5.5
	4	Q3EP315M4B	Cast Iron	652	1206,0	2*M63	457	508	315	833	28	216	80	170	85	22	6319	6319	95*115*5.5	95*115*5.5
160,0	2	Q3EP315L2A	Cast Iron	652	1287,0	2*M63	508	508	315	833	28	216	65	140	69	18	6316	6316	80*100*5.5	80*100*5.5
	4	Q3EP315L4A	Cast Iron	652	1317,0	2*M63	508	508	315	833	28	216	80	170	85	22	6319	6319	95*115*5.5	95*115*5.5
200,0	2	Q3EP315L2C	Cast Iron	652	1287,0	2*M63	508	508	315	833	28	216	65	140	69	18	6316	6316	80*100*5.5	80*100*5.5
	4	Q3EP315L4C	Cast Iron	652	1317,0	2*M63	508	508	315	833	28	216	80	170	85	22	6319	6319	95*115*5.5	95*115*5.5
250,0	2	Q3EP355M2C	Cast Iron	762	1512,0	4*M63	560	610	355	997	28	254	75	140	80	20	6317	6317	85*105*5.5	85*105*5.5
	4	Q3EP355M4C	Cast Iron	762	1542,0	4*M63	560	610	355	997	28	254	95	170	100	25	6322	6322	110*130*5.5	110*130*5.5
315,0	2	Q3EP355L2B	Cast Iron	762	1512,0	4*M63	630	610	355	997	28	254	75	140	80	20	6317	6317	85*105*5.5	85*105*5.5
	4	Q3EP355L4B	Cast Iron	762	1542,0	4*M63	630	610	355	997	28	254	95	170	100	25	6322	6322	110*130*5.5	110*130*5.5
355,0	2	Q3EP355L2C	Cast Iron	762	1512,0	4*M63	630	610	355	997	28	254	75	140	80	20	6317	6317	85*105*5.5	85*105*5.5
	4	Q3EP355L4C	Cast Iron	762	1542,0	4*M63	630	610	355	997	28	254	95	170	100	25	6322	6322	110*130*5.5	110*130*5.5

(1) Tolerance DIN EN 50347 "j6" up to 28 mm "k6" above 28 mm
 (2) According to DIN 6885

DIMENSIONS - B5, B35

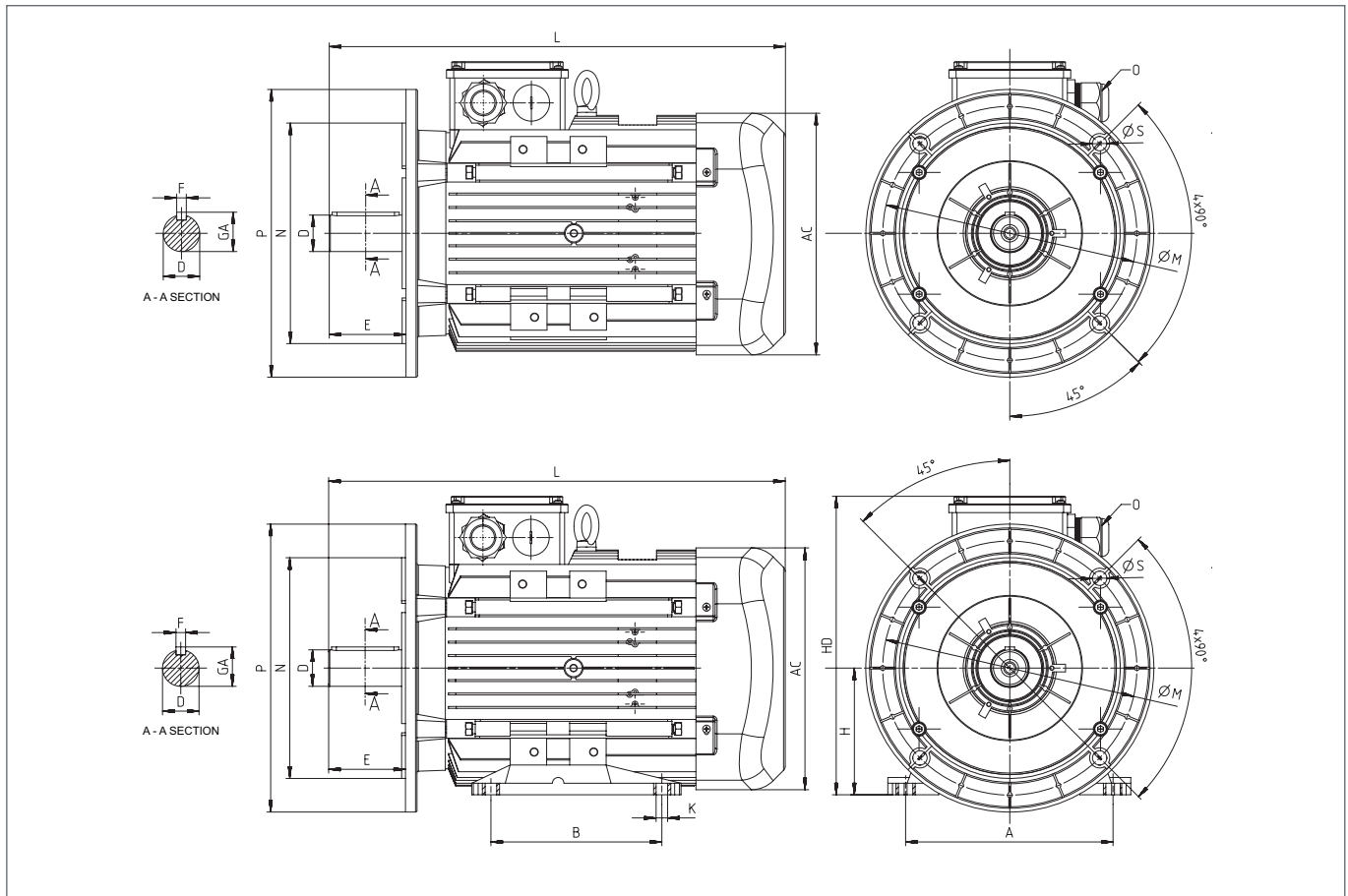

Power (kW)	Number of Poles	Motor Type	Housing Type	Main Dimensions		Foot Mounted Motors					Shaft			Bearing		Seal		Flange (FA) (B5)						
				AC	L	O	B	A	H	HD	K	D ⁽¹⁾	E	GA	F ⁽²⁾	Drive Side	Non Drive Side	Drive Side	Non Drive Side	P	N ⁽³⁾	M	R	S
0,75	2	Q3E80M2C	Aluminum	158	283,5	1*M20	100	125	80	195	10	19	40	21,5	6	6204-2Z	6204-2Z	20*30*7	20*30*7	200	130	165	0	12
	4	Q3E80M4D	Aluminum	158	283,5	1*M20	100	125	80	195	10	19	40	21,5	6	6204-2Z	6204-2Z	20*30*7	20*30*7	200	130	165	0	12
	6	Q3E90L6C	Aluminum	193	316,5	1*M25	125	140	90	222	10	24	50	27	8	6305-2Z	6205-2Z	25*40*7	25*40*7	200	130	165	0	12
1,1	2	Q3E80M2D	Aluminum	158	283,5	1*M20	100	125	80	195	10	19	40	21,5	6	6204-2Z	6204-2Z	20*30*7	20*30*7	200	130	165	0	12
	4	Q3E90L4C	Aluminum	193	316,5	1*M25	100	140	90	222	10	24	50	27	8	6305-2Z	6205-2Z	25*40*7	25*40*7	200	130	165	0	12
	6	Q3E90L6D	Aluminum	193	344,5	1*M25	125	140	90	222	10	24	50	27	8	6305-2Z	6205-2Z	25*40*7	25*40*7	200	130	165	0	12
1,5	2	Q3E90L2C	Aluminum	193	316,5	1*M25	100	140	90	222	10	24	50	27	8	6305-2Z	6205-2Z	25*40*7	25*40*7	200	130	165	0	12
	4	Q3E90L4D	Aluminum	193	344,5	1*M25	125	140	90	222	10	24	50	27	8	6305-2Z	6205-2Z	25*40*7	25*40*7	200	130	165	0	12
	6	Q3E100L6D	Aluminum	217	352,0	1*M25	140	160	100	241	12	28	60	31	8	6306-2Z	6205-2Z	30*47*7	25*47*7	250	180	215	0	15
2,2	2	Q3E90L2D	Aluminum	193	316,5	1*M25	125	140	90	222	10	24	50	27	8	6305-2Z	6205-2Z	25*40*7	25*40*7	200	130	165	0	12
	4	Q3E100L4C	Aluminum	217	352,0	1*M25	140	160	100	241	12	28	60	31	8	6306-2Z	6205-2Z	30*47*7	25*40*7	250	180	215	0	15
	6	Q3E112M6D	Aluminum	232	395,5	2*M25	140	190	112	261	12	28	60	31	8	6306-2Z	6206-2Z	30*47*7	30*47*7	250	180	215	0	15
3,0	2	Q3E100L2C	Aluminum	217	352,0	1*M25	140	160	100	241	12	28	60	31	8	6306-2Z	6205-2Z	30*47*7	25*40*7	250	180	215	0	15
	4	Q3E100L4D	Aluminum	217	377,0	1*M25	140	160	100	241	12	28	60	31	8	6306-2Z	6205-2Z	30*47*7	25*40*7	250	180	215	0	15
	6	Q3E132M6B	Aluminum	260	481,0	2*M32	178	216	132	323	12	38	80	41	10	6208-2Z	6208-2Z	40*62*10	40*62*10	300	230	265	0	15
4,0	2	Q3E112M2C	Aluminum	232	395,5	2*M25	140	190	112	261	12	28	60	31	8	6306-2Z	6206-2Z	30*47*7	30*47*7	250	180	215	0	15
	4	Q3E112M4C	Aluminum	232	395,5	2*M25	140	190	112	261	12	28	60	31	8	6306-2Z	6206-2Z	30*47*7	30*47*7	250	180	215	0	15
	6	Q3E132M6C	Aluminum	260	481,0	2*M32	178	216	132	323	12	38	80	41	10	6208-2Z	6208-2Z	40*62*10	40*62*10	300	230	265	0	15
5,5	2	Q3E132S2C	Aluminum	279	440,5	2*M32	140	216	132	314	12	38	80	41	10	6208-2Z	6208-2Z	40*62*10	40*62*10	300	230	265	0	15
	4	Q3E132M4B	Aluminum	279	475,5	2*M32	140	216	132	314	12	38	80	41	10	6208-2Z	6208-2Z	40*62*10	40*62*10	300	230	265	0	15
	6	Q3E132M6D	Aluminum	260	481,0	2*M32	178	216	132	323	12	38	80	41	10	6208-2Z	6208-2Z	40*62*10	40*62*10	300	230	265	0	15
7,5	2	Q3E132M2A	Aluminum	279	475,5	2*M32	140	216	132	314	12	38	80	41	10	6208-2Z	6208-2Z	40*62*10	40*62*10	300	230	265	0	15
	4	Q3E132M4C	Aluminum	279	475,5	2*M32	178	216	132	314	12	38	80	41	10	6208-2Z	6208-2Z	40*62*10	40*62*10	300	230	265	0	15
	6	Q3E160L6C	Aluminum	302	576,0	2*M32	254	254	160	360	15	42	110	45	12	6309-2Z	6209-2Z	45*72*10	45*72*10	350	250	300	0	19
11,0	2	Q3E160L2A	Aluminum	302	576,0	2*M32	254	254	160	360	15	42	110	45	12	6309-2Z	6209-2Z	45*72*10	45*72*10	350	250	300	0	19
	4	Q3E160L4A	Aluminum	302	576,0	2*M32	254	254	160	360	15	42	110	45	12	6309-2Z	6209-2Z	45*72*10	45*72*10	350	250	300	0	19
	6	Q3E160L6D	Aluminum	302	576,0	2*M32	254	254	160	360	15	42	110	45	12	6309-2Z	6209-2Z	45*72*10	45*72*10	350	250	300	0	19

DIMENSIONS - B5, B35

Power (kW)	Number of Poles	Motor Type	Housing Type	Main Dimensions			Foot Mounted Motors					Shaft				Bearing		Seal		Flange (FA) (B5)				
				AC	L	O	B	A	H	HD	K	D ⁽¹⁾	E	GA	F ⁽²⁾	Drive Side	Non Drive Side	Drive Side	Non Drive Side	P	N ⁽³⁾	M	R	S
15,0	2	Q3E160L2C	Aluminum	302	576,0	2*M32	254	254	160	360	15	42	110	45	12	6309-2Z	6209-2Z	45*72*10	45*72*10	350	250	300	0	19
	4	Q3E160L4B	Aluminum	302	576,0	2*M32	254	254	160	360	15	42	110	45	12	6309-2Z	6209-2Z	45*72*10	45*72*10	350	250	300	0	19
	6	Q3E180L6B	Aluminum	347	689,0	2*M40	279	279	180	452	15	48	110	51,5	14	6310-2Z	6310-2Z	50*80*10	50*80*10	350	250	300	0	19
18,5	2	Q3E160L2C	Aluminum	302	576,0	2*M32	254	254	160	360	15	42	110	45	12	6309-2Z	6209-2Z	45*72*10	45*72*10	350	250	300	0	19
	4	Q3E180M4B	Aluminum	370	629,0	2*M40	241	279	180	428	15	48	110	51,5	14	6310-2Z	6310-2Z	50*80*10	50*80*10	350	250	300	0	19
	6	Q3E200L6C	Aluminum	415	665,0	2*M50	305	318	200	461	19	55	110	59	16	6312-2Z	6312-2Z	60*90*10	60*90*10	400	300	350	0	19
22,0	2	Q3E160L2D	Aluminum	302	576,0	2*M32	210	254	160	360	15	42	110	45	12	6309-2Z	6209-2Z	45*72*10	45*72*10	350	250	300	0	19
	2	Q3E180M2A	Aluminum	370	629,0	2*M40	241	279	180	428	15	48	110	51,5	14	6310-2Z	6310-2Z	50*80*10	50*80*10	350	250	300	0	19
	4	Q3E180L4B	Aluminum	370	629,0	2*M40	279	279	180	428	15	48	110	51,5	14	6310-2Z	6310-2Z	50*80*10	50*80*10	350	250	300	0	19
30,0	2	Q3E200L2B	Aluminum	415	665,0	2*M50	305	318	200	461	19	55	110	59	16	6312-2Z	6312-2Z	60*90*10	60*90*10	400	300	350	0	19
	4	Q3E200L4D	Aluminum	415	665,0	2*M50	305	318	200	461	19	55	110	59	16	6312-2Z	6310-2Z	60*90*10	50*80*10	400	300	350	0	19
	6	Q3E225M6C	Aluminum	456	765,0	2*M40	311	356	225	485	19	60	140	64	18	6313-2Z	6313-2Z	65*100*13	65*100*13	450	350	400	0	19
37,0	2	Q3E200L2C	Aluminum	415	665,0	2*M50	305	318	200	461	19	55	110	59	16	6312-2Z	6310-2Z	60*90*10	50*80*10	400	300	350	0	19
	4	Q3E225M4C	Aluminum	456	765,0	2*M50	286	356	225	504	19	60	140	64	18	6313-2Z	6313-2Z	65*100*13	65*100*13	450	350	400	0	19
45,0	2	Q3E225M2B	Aluminum	456	735,0	2*M50	311	356	225	504	19	55	110	59	16	6313-2Z	6313-2Z	65*100*13	65*100*13	450	350	400	0	19
	4	Q3E225M4D	Aluminum	456	765,0	2*M50	311	356	225	504	19	60	140	64	18	6313-2Z	6313-2Z	65*100*13	65*100*13	450	350	400	0	19
55,0	2	Q3EP250M2C	Cast Iron	527	886,0	2*M50	349	406	250	615	24	60	140	64	18	6316	6316	80*100*10	80*100*10	550	450	500	0	19
	4	Q3EP250M4E	Cast Iron	527	886,0	2*M50	349	406	250	615	24	65	140	69	18	6316	6316	80*100*10	80*100*10	550	450	500	0	19
75,0	2	Q3EP280M2C	Cast Iron	527	1025,0	2*M50	419	457	280	647	24	65	140	69	18	6316	6316	80*100*10	80*100*10	550	450	500	0	19
	4	Q3EP280M4C	Cast Iron	527	1025,0	2*M50	419	457	280	647	24	75	140	80	20	6316	6316	80*100*10	80*100*10	550	450	500	0	19
90,0	4	Q3EP280M2D	Cast Iron	527	1025,0	2*M50	419	457	280	647	24	65	140	69	18	6316	6316	80*100*10	80*100*10	550	450	500	0	19
	4	Q3EP280M4D	Cast Iron	527	1025,0	2*M50	419	457	280	647	24	75	140	80	20	6316	6316	80*100*10	80*100*10	550	450	500	0	19
110,0	2	Q3EP315S2C	Cast Iron	652	1176,0	2*M63	406	508	315	833	28	65	140	69	18	6316	6316	80*100*5,5	80*100*5,5	660	550	600	0	24
	4	Q3EP315S4C	Cast Iron	652	1206,0	2*M63	406	508	315	833	28	80	170	85	22	6319	6319	95*115*5,5	95*115*5,5	660	550	600	0	24
132,0	2	Q3EP315M2B	Cast Iron	652	1176,0	2*M63	457	508	315	833	28	65	140	69	18	6316	6316	80*100*5,5	80*100*5,5	660	550	600	0	24
	4	Q3EP315M4B	Cast Iron	652	1206,0	2*M63	457	508	315	833	28	80	170	85	22	6319	6319	95*115*5,5	95*115*5,5	660	550	600	0	24
160,0	2	Q3EP315L2A	Cast Iron	652	1287,0	2*M63	508	508	315	833	28	65	140	69	18	6316	6316	80*100*5,5	80*100*5,5	660	550	600	0	24
	4	Q3EP315L4A	Cast Iron	652	1317,0	2*M63	508	508	315	833	28	80	170	85	22	6319	6319	95*115*5,5	95*115*5,5	660	550	600	0	24
200,0	2	Q3EP315L2C	Cast Iron	652	1287,0	2*M63	508	508	315	833	28	65	140	69	18	6316	6316	80*100*5,5	80*100*5,5	660	550	600	0	24
	4	Q3EP315L4C	Cast Iron	652	1317,0	2*M63	508	508	315	833	28	80	170	85	22	6319	6319	95*115*5,5	95*115*5,5	660	550	600	0	24
250,0	2	Q3EP355M2C	Cast Iron	762	1512,0	4*M63	560	610	355	997	28	75	140	80	20	6317	6317	85*105*5,5	85*105*5,5	800	680	740	0	24
	4	Q3EP355M4C	Cast Iron	762	1542,0	4*M63	560	610	355	997	28	95	170	100	25	6322	6322	110*130*5,5	110*130*5,5	800	680	740	0	24
315,0	2	Q3EP355L2B	Cast Iron	762	1512,0	4*M63	630	610	355	997	28	75	140	80	20	6317	6317	85*105*5,5	85*105*5,5	800	680	740	0	24
	4	Q3EP355L4B	Cast Iron	762	1542,0	4*M63	630	610	355	997	28	95	170	100	25	6322	6322	110*130*5,5	110*130*5,5	800	680	740	0	24
355,0	2	Q3EP355L2C	Cast Iron	762	1512,0	4*M63	630	610	355	997	28	75	140	80	20	6317	6317	85*105*5,5	85*105*5,5	800	680	740	0	24
	4	Q3EP355L4C	Cast Iron	762	1542,0	4*M63	630	610	355	997	28	95	170	100	25	6322	6322	110*130*5,5	110*130*5,5	800	680	740	0	24

(1) Tolerance DIN EN 50347 "j6" up to 28 mm "k6" above 28 mm

(2) According to DIN 6885

(3) Tolerance DIN EN 50347 "j6"

DIMENSIONS - B14a, B34a

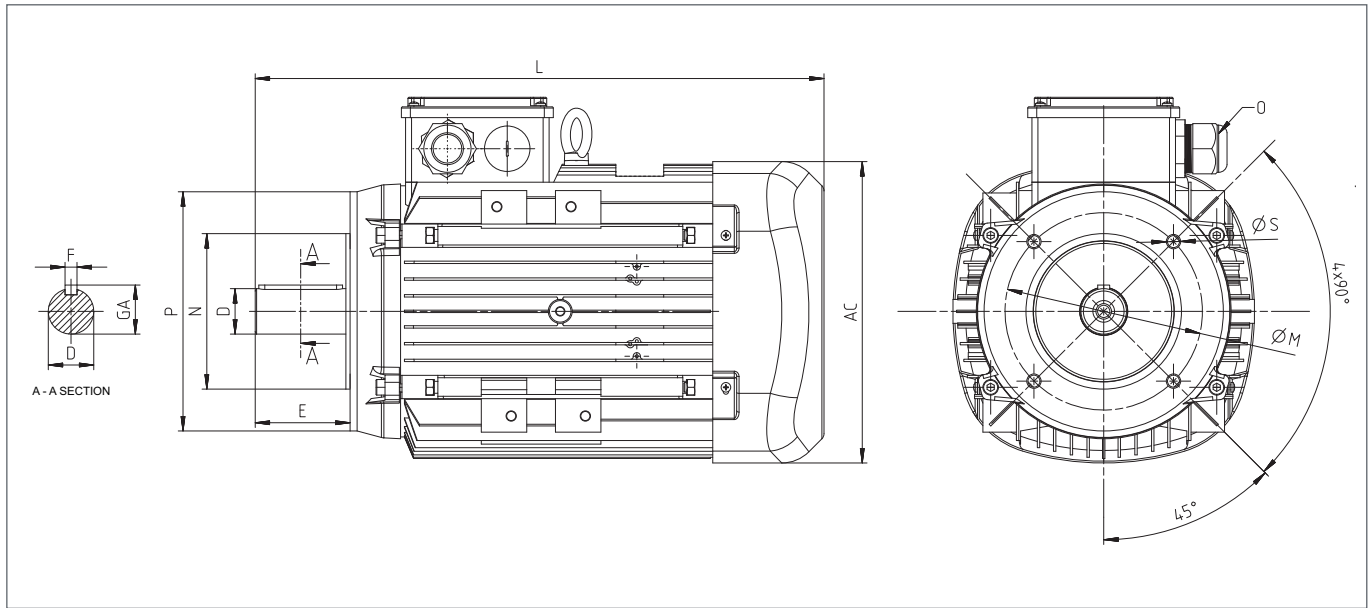

Power (kW)	Number of Poles	Motor Type	Housing Type	Main Dimensions			Foot Mounted Motors					Shaft				Bearing		Seal		Flange (FC) (B14a)				
				AC	L	O	B	A	H	HD	K	D ⁽¹⁾	E	GA	F ⁽²⁾	Drive Side	Non Drive Side	Drive Side	Non Drive Side	P	N ⁽³⁾	M	R	S
0,75	2	Q3E80M2C	Aluminum	158	283,5	1*M20	100	125	80	195	10	19	40	21,5	6	6204-2Z	6204-2Z	20*30*7	20*30*7	120	80	100	0	M6
	4	Q3E80M4D	Aluminum	158	283,5	1*M20	100	125	80	195	10	19	40	21,5	6	6204-2Z	6204-2Z	20*30*7	20*30*7	120	80	100	0	M6
	6	Q3E90L6C	Aluminum	193	316,5	1*M25	125	140	90	222	10	24	50	27	8	6305-2Z	6205-2Z	25*40*7	25*40*7	200	130	165	0	12
1,1	2	Q3E80M2D	Aluminum	158	283,5	1*M20	100	125	80	195	10	19	40	21,5	6	6204-2Z	6204-2Z	20*30*7	20*30*7	120	80	100	0	M6
	4	Q3E90L4C	Aluminum	193	316,5	1*M25	100	140	90	222	10	24	50	27	8	6305-2Z	6205-2Z	25*40*7	25*40*7	140	95	115	0	M8
	6	Q3E90L6D	Aluminum	193	344,5	1*M25	125	140	90	222	10	24	50	27	8	6305-2Z	6205-2Z	25*40*7	25*40*7	200	130	165	0	12
1,5	2	Q3E90L2C	Aluminum	193	316,5	1*M25	100	140	90	222	10	24	50	27	8	6305-2Z	6205-2Z	25*40*7	25*40*7	140	95	115	0	M8
	4	Q3E90L4D	Aluminum	193	344,5	1*M25	125	140	90	222	10	24	50	27	8	6305-2Z	6205-2Z	25*40*7	25*40*7	140	95	115	0	M8
	6	Q3E100L6D	Aluminum	217	352,0	1*M25	140	160	100	241	12	28	60	31	8	6306-2Z	6205-2Z	30*47*7	25*40*7	250	180	215	0	15
2,2	2	Q3E90L2D	Aluminum	193	316,5	1*M25	125	140	90	222	10	24	50	27	8	6305-2Z	6205-2Z	25*40*7	25*40*7	140	95	115	0	M8
	4	Q3E100L4C	Aluminum	217	352,0	1*M25	140	160	100	241	12	28	60	31	8	6306-2Z	6205-2Z	30*47*7	25*40*7	160	110	130	0	M8
	6	Q3E112M6D	Aluminum	232	395,5	2*M25	140	190	112	261	12	28	60	31	8	6306-2Z	6206-2Z	30*47*7	30*47*7	250	180	215	0	15
3,0	2	Q3E100L2C	Aluminum	217	352,0	1*M25	140	160	100	241	12	28	60	31	8	6306-2Z	6205-2Z	30*47*7	25*40*7	160	110	130	0	M8
	4	Q3E100L4D	Aluminum	217	377,0	1*M25	140	160	100	241	12	28	60	31	8	6306-2Z	6205-2Z	30*47*7	25*40*7	160	110	130	0	M8
	6	Q3E132M6B	Aluminum	260	481,0	2*M32	178	216	132	323	12	38	80	41	10	6208-2Z	6208-2Z	40*62*10	40*62*10	300	230	265	0	15
4,0	2	Q3E112M2C	Aluminum	232	395,5	2*M25	140	190	112	261	12	28	60	31	8	6306-2Z	6206-2Z	30*47*7	30*47*7	160	110	130	0	M8
	4	Q3E112M4C	Aluminum	232	395,5	2*M25	140	190	112	261	12	28	60	31	8	6306-2Z	6206-2Z	30*47*7	30*47*7	160	110	130	0	M8
	6	Q3E132M6C	Aluminum	260	481,0	2*M32	178	216	132	323	12	38	80	41	10	6208-2Z	6208-2Z	40*62*10	40*62*10	300	230	265	0	15
5,5	2	Q3E132S2C	Aluminum	279	440,5	2*M32	140	216	132	314	12	38	80	41	10	6208-2Z	6208-2Z	40*62*10	40*62*10	200	130	165	0	M10
	4	Q3E132M4B	Aluminum	279	475,5	2*M32	140	216	132	314	12	38	80	41	10	6208-2Z	6208-2Z	40*62*10	40*62*10	200	130	165	0	M10
	6	Q3E132M6D	Aluminum	260	481,0	2*M32	178	216	132	323	12	38	80	41	10	6208-2Z	6208-2Z	40*62*10	40*62*10	300	230	265	0	15
7,5	2	Q3E132M2A	Aluminum	279	475,5	2*M32	140	216	132	314	12	38	80	41	10	6208-2Z	6208-2Z	40*62*10	40*62*10	200	130	165	0	M10
	4	Q3E132M4C	Aluminum	279	475,5	2*M32	178	216	132	314	12	38	80	41	10	6208-2Z	6208-2Z	40*62*10	40*62*10	200	130	165	0	M10

(1) Tolerance DIN EN 50347 "j6" up to 28 mm "k6" above 28 mm
 (2) According to DIN 6885
 (3) Tolerance DIN EN 50347 "j6"

DIMENSIONS - B14b, B34b

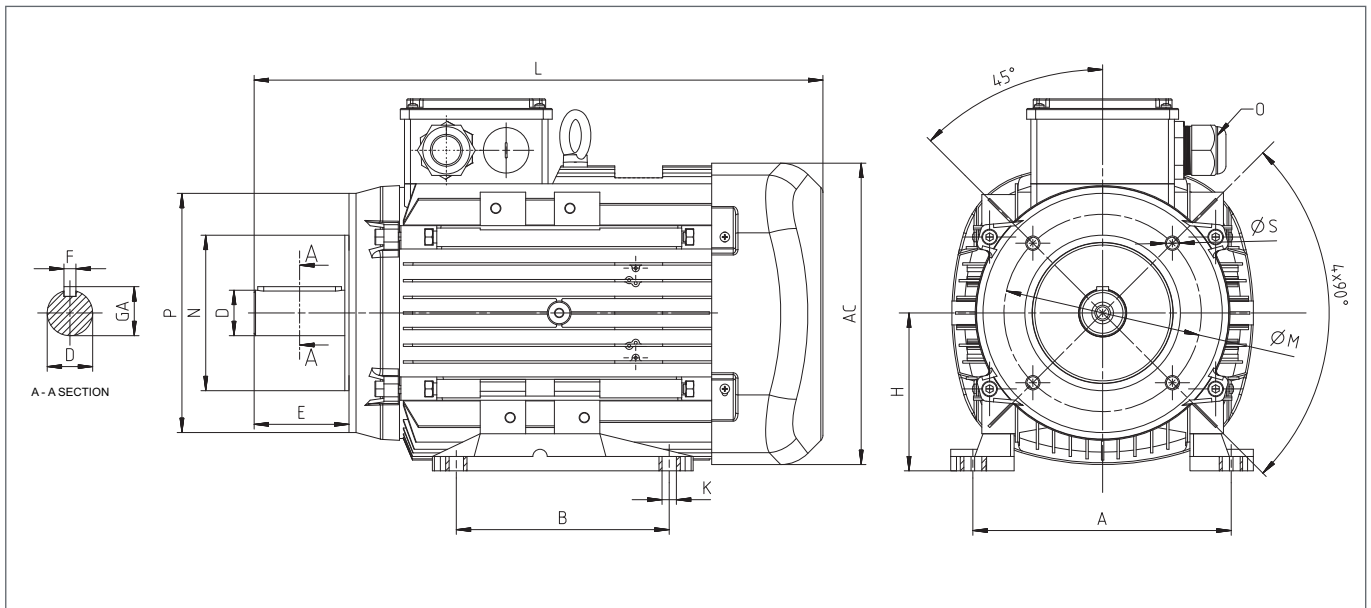

Power (kW)	Number of Poles	Motor Type	Housing Type	Main Dimensions				Foot Mounted Motors				Shaft				Bearing		Seal		Flange (FB) (B14b)				
				AC	L	O	B	A	H	HD	K	D ⁽¹⁾	E	GA	F ⁽²⁾	Drive Side	Non Drive Side	Drive Side	Non Drive Side	P	N ⁽³⁾	M	R	S
0,75	2	Q3E80M2C	Aluminum	158	283,5	1*M20	100	125	80	195	10	19	40	21,5	6	6204-2Z	6204-2Z	20*30*7	20*30*7	160	110	130	0	M8
	4	Q3E80M4D	Aluminum	158	283,5	1*M20	100	125	80	195	10	19	40	21,5	6	6204-2Z	6204-2Z	20*30*7	20*30*7	160	110	130	0	M8
	6	Q3E90L6C	Aluminum	193	316,5	1*M25	125	140	90	222	10	24	50	27	8	6305-2Z	6205-2Z	25*40*7	25*40*7	200	130	165	0	12
1,1	2	Q3E80M2D	Aluminum	158	283,5	1*M20	100	125	80	195	10	19	40	21,5	6	6204-2Z	6204-2Z	20*30*7	20*30*7	160	110	130	0	M8
	4	Q3E90L4C	Aluminum	193	316,5	1*M25	100	140	90	222	10	24	50	27	8	6305-2Z	6205-2Z	25*40*7	25*40*7	160	110	130	0	M8
	6	Q3E90L6D	Aluminum	193	344,5	1*M25	125	140	90	222	10	24	50	27	8	6305-2Z	6205-2Z	25*40*7	25*40*7	200	130	165	0	12
1,5	2	Q3E90L2C	Aluminum	193	316,5	1*M25	100	140	90	222	10	24	50	27	8	6305-2Z	6205-2Z	25*40*7	25*40*7	160	110	130	0	M8
	4	Q3E90L4D	Aluminum	193	344,5	1*M25	125	140	90	222	10	24	50	27	8	6305-2Z	6205-2Z	25*40*7	25*40*7	160	110	130	0	M8
	6	Q3E100L6D	Aluminum	217	352,0	1*M25	140	160	100	241	12	28	60	31	8	6306-2Z	6205-2Z	30*47*7	25*47*7	250	180	215	0	15
2,2	2	Q3E90L2D	Aluminum	193	316,5	1*M25	125	140	90	222	10	24	50	27	8	6305-2Z	6205-2Z	25*40*7	25*40*7	160	110	130	0	M8
	4	Q3E100L4C	Aluminum	217	352,0	1*M25	140	160	100	241	12	28	60	31	8	6306-2Z	6205-2Z	30*47*7	25*40*7	200	130	165	0	M10
	6	Q3E112M6D	Aluminum	232	395,5	2*M25	140	190	112	261	12	28	60	31	8	6306-2Z	6206-2Z	30*47*7	30*47*7	250	180	215	0	15
3,0	2	Q3E100L2C	Aluminum	217	352,0	1*M25	140	160	100	241	12	28	60	31	8	6306-2Z	6205-2Z	30*47*7	25*40*7	200	130	165	0	M10
	4	Q3E100L4D	Aluminum	217	377,0	1*M25	140	160	100	241	12	28	60	31	8	6306-2Z	6205-2Z	30*47*7	25*40*7	200	130	165	0	M10
	6	Q3E132M6B	Aluminum	260	481,0	2*M32	178	216	132	323	12	38	80	41	10	6208-2Z	6208-2Z	40*62*10	40*62*10	300	230	265	0	15
4,0	2	Q3E112M2C	Aluminum	232	395,5	2*M25	140	190	112	261	12	28	60	31	8	6306-2Z	6206-2Z	30*47*7	30*47*7	200	130	165	0	M10
	4	Q3E112M4C	Aluminum	232	395,5	2*M25	140	190	112	261	12	28	60	31	8	6306-2Z	6206-2Z	30*47*7	30*47*7	200	130	165	0	M10
	6	Q3E132M6C	Aluminum	260	481,0	2*M32	178	216	132	323	12	38	80	41	10	6208-2Z	6208-2Z	40*62*10	40*62*10	300	230	265	0	15
5,5	2	Q3E132S2C	Aluminum	279	440,5	2*M32	140	216	132	314	12	38	80	41	10	6208-2Z	6208-2Z	40*62*10	40*62*10	250	180	215	0	M12 or 15
	4	Q3E132M4B	Aluminum	279	475,5	2*M32	140	216	132	314	12	38	80	41	10	6208-2Z	6208-2Z	40*62*10	40*62*10	250	180	215	0	M12 or 15
	6	Q3E132M6D	Aluminum	260	481,0	2*M32	178	216	132	323	12	38	80	41	10	6208-2Z	6208-2Z	40*62*10	40*62*10	300	230	265	0	15
7,5	2	Q3E132M2A	Aluminum	279	475,5	2*M32	140	216	132	314	12	38	80	41	10	6208-2Z	6208-2Z	40*62*10	40*62*10	250	180	215	0	M12 or 15
	4	Q3E132M4C	Aluminum	279	475,5	2*M32	178	216	132	314	12	38	80	41	10	6208-2Z	6208-2Z	40*62*10	40*62*10	250	180	215	0	M12 or 15

(1) Tolerance DIN EN 50347 "j6" up to 28 mm "k6" above 28 mm

(2) According to DIN 6885

(3) Tolerance DIN EN 50347 "j6"

ELECTRICAL CHARACTERISTICS AT 50 Hz

Motor Type	Housing Type	Rated Values						Starting Values				Breakdown Torque Ratio Mk/Mn	Efficiency*			Cos φ	J kgm ²	Weight (B3) kg	Sound Pressure Level dBA**
		Power		Speed	Current	Torque	Current		Torque		η%		4/4	3/4	2/4				
		kW	HP	d/d	A	Nm	I _A / A _N	Δ	M _A / M _N	Δ									
2pole3000d/d																			
220/380V	Q2E71M2C*	Aluminum	0,37	1/2	2850	1,0	1,2	7,7	-	3,6	-	3,8	69,5	69,6	67,3	0,80	0,00067	8	54
	Q2E71M2D*	Aluminum	0,55	3/4	2860	1,2	1,8	7,8	-	3,7	-	3,9	74,1	74,2	72,0	0,82	0,00086	9,7	54
	Q2E80M2B	Aluminum	0,75	1,0	2860	1,7	2,5	7,7	-	3,7	-	4,0	77,4	77,0	73,6	0,84	0,00109	11	58
	Q2E80M2D	Aluminum	1,1	1,5	2860	2,4	3,6	7,7	-	3,7	-	4,1	79,6	79,1	77,1	0,84	0,00150	13	58
	Q2E90L2C	Aluminum	1,5	2,0	2900	3,2	5,0	7,8	-	3,4	-	4,0	81,3	80,8	77,7	0,83	0,00182	17	62
	Q2E90L2D	Aluminum	2,2	3,0	2900	4,7	7,3	7,9	-	3,5	-	4,1	83,2	82,9	80,5	0,84	0,00182	18	62
	Q2E100L2C	Aluminum	3,0	4,0	2875	6,0	9,9	9,1	-	3,9	-	4,6	84,6	84,5	83,1	0,90	0,00335	21	64
380/660V	Q2E112M2C	Aluminum	4,0	5,5	2900	7,7	13,2	2,9	8,6	1,3	3,8	4,5	85,8	85,7	84,3	0,88	0,00489	31	67
	Q2E132S2C	Aluminum	5,5	7,5	2900	10,4	18,0	3,0	8,9	1,1	3,2	4,2	87,0	86,9	85,2	0,91	0,01410	46	70
	Q2E132M2A	Aluminum	7,5	10,0	2920	13,6	24,5	2,9	8,6	1,0	3,0	3,7	88,1	87,7	85,9	0,90	0,01596	53	70
	Q2E160M2B	Aluminum	11,0	15,0	2930	20,3	35,9	3,1	9,4	1,0	3,0	3,8	89,4	89,3	87,5	0,91	0,02644	76	71
	Q2E160L2A	Aluminum	15,0	20,0	2930	27,0	48,7	2,9	8,6	1,0	3,0	3,3	90,3	90,2	88,4	0,93	0,03317	82	71
	Q2E160L2C	Aluminum	18,5	25,0	2930	32,8	60,0	3,3	10,0	0,5	1,4	4,3	90,9	90,8	89,0	0,91	0,04075	90	71
	Q2E180M2A	Aluminum	22,0	30,0	2945	38,7	71,3	2,6	7,9	0,7	2,2	3,4	91,3	90,9	89,5	0,91	0,06193	114	77
	Q2E200L2B	Aluminum	30,0	40,0	2955	56,6	97,1	2,6	7,9	0,6	1,9	4,1	92,0	91,4	89,6	0,86	0,11917	167	80
	Q2E200L2C	Aluminum	37,0	50,0	2955	66,8	119,4	2,8	8,3	0,6	1,9	3,1	92,5	91,9	90,1	0,91	0,15010	167	80
	Q2E225M2B	Aluminum	45,0	60,0	2965	85,7	145,2	2,8	8,3	0,7	2,2	3,4	92,9	92,6	91,1	0,86	0,23505	235	81
	Q2EP250M2B	Cast Iron	55,0	75,0	2970	97,9	178,5	1,7	5,1	0,7	2,1	3,1	93,2	92,1	90,9	0,91	0,48707	486	82
	Q2EP280M2B	Cast Iron	75,0	100,0	2970	135,0	241,1	3,0	9,1	0,7	2,1	2,6	93,8	93,7	92,5	0,90	0,54033	576	84
Q2EP280M2C	Cast Iron	90,0	125,0	2970	156,5	291,3	3,3	10,0	1,1	3,2	3,6	94,1	93,9	92,9	0,93	0,64510	585	84	
400/690V	Q2EP315S2C	Cast Iron	110,0	127,0	2,975	185	353	2,6	7,8	0,7	2,2	2,4	94,3	94,3	93,1	0,91	1,43600	920	87
	Q2EP315M2C	Cast Iron	132,0	152,0	2,975	221	423	2,6	7,8	0,8	2,3	2,4	94,6	94,6	93,4	0,91	1,72300	970	87
	Q2EP315L2C	Cast Iron	160,0	184,0	2,975	268	513	2,5	7,5	0,8	2,3	2,4	94,8	94,8	93,6	0,91	1,95300	1.170	87
	Q2EP315L2D	Cast Iron	200,0	230,0	2,975	334	643	2,7	8,0	0,8	2,4	2,6	95,0	95,0	93,8	0,91	2,52700	1.200	87
	Q2EP355M2C	Cast Iron	250,0	280,0	2,985	422	799	2,3	7,0	0,7	2,0	2,4	95,0	95,0	93,8	0,90	3,92000	1.690	87
	Q2EP355L2C	Cast Iron	315,0	353,0	2,985	532	1.007	2,5	7,4	0,7	2,0	2,3	95,0	95,0	93,8	0,90	4,17000	1.870	87
	Q2EP355L2D	Cast Iron	355,0	398,0	2,985	599	1.135	2,5	7,5	0,6	1,8	2,1	95,0	95,0	93,8	0,90	4,44000	1.953	87
4pole1500d/d																			
220/380V	Q2E71M4C*	Aluminum	0,25	1/3	1415	0,7	1,7	4,4	-	2,3	-	3,4	68,5	68,8	68,8	0,74	0,00095	9	45
	Q2E71M4D*	Aluminum	0,37	1/2	1415	1,1	2,5	4,4	-	2,3	-	3,4	72,7	73,1	72,0	0,75	0,00095	8,5	45
	Q2E80M4B*	Aluminum	0,55	3/4	1415	1,5	3,7	4,8	-	2,8	-	3,2	77,1	77,6	76,4	0,76	0,00205	10,5	49
	Q2E80M4D	Aluminum	0,75	1,0	1435	2	5,1	5,2	-	2,9	-	3,2	79,6	78,9	75,3	0,7	0,00268	12	49
	Q2E90L4C	Aluminum	1,1	1,5	1430	2,5	7,4	6,7	-	2,9	-	3,3	81,4	80,8	78,1	0,81	0,00365	18	54
	Q2E90L4D	Aluminum	1,5	2,0	1430	3,5	10,0	7,0	-	3,2	-	3,6	82,8	82,0	79,3	0,76	0,00365	18	55
	Q2E100L4C	Aluminum	2,2	3,0	1430	5,0	14,6	7,1	-	3,9	-	4,2	84,3	83,8	81,2	0,77	0,00545	26	56
	Q2E100L4D	Aluminum	3,0	4,0	1440	6,4	20,0	7,1	-	3,4	-	3,8	85,5	85,1	83,0	0,75	0,00581	26	56
	380/660V	Q2E112M4C	Aluminum	4,0	5,5	1440	8,7	26,3	2,6	7,9	0,9	2,8	3,9	86,6	86,0	84,5	0,81	0,01123	31
Q2E132M4B		Aluminum	5,5	7,5	1450	11,7	36,2	2,4	7,1	1,1	3,2	3,9	87,7	87,6	85,2	0,81	0,02763	54	61
Q2E132M4C		Aluminum	7,5	10,0	1450	15,8	49,4	2,9	8,7	0,9	2,8	4,1	88,7	88,5	86,6	0,80	0,02980	57	61
Q2E160M4B		Aluminum	11,0	15,0	1460	22,5	72,5	2,0	6,0	0,7	2,2	2,7	89,8	89,7	88,2	0,83	0,05547	76	63
Q2E160L4A		Aluminum	15,0	20,0	1460	28,8	98,5	2,0	6,0	0,8	2,3	2,7	90,6	90,5	89,5	0,83	0,06922	92	63
Q2E180M4B		Aluminum	18,5	25,0	1465	36,5	121,4	2,5	7,4	1,0	3,0	4,1	91,2	91,1	90,2	0,84	0,11220	119	69
Q2E180L4B		Aluminum	22,0	30,0	1465	44,5	143,5	2,6	7,7	0,8	2,4	3,4	91,6	91,5	90,6	0,82	0,12773	127	69
Q2E200L4D		Aluminum	30,0	40,0	1465	57,3	195,6	2,4	7,3	0,8	2,5	3,2	92,3	92,1	91,1	0,86	0,26448	177	70
Q2E225M4C		Aluminum	37,0	50,0	1480	70,7	240,0	2,5	7,5	1,0	2,9	3,5	92,7	92,6	91,5	0,84	0,36429	260	71
Q2E225M4D		Aluminum	45,0	60,0	1470	85,9	292,3	2,6	7,7	1,0	2,9	3,5	93,1	93,0	91,9	0,85	0,43513	280	71
Q2EP250M4D		Cast Iron	55,0	75,0	1480	105,0	359,0	2,4	7,1	0,7	2,1	2,9	93,5	93,2	90,7	0,83	0,90782	506	72
Q2EP280M4B		Cast Iron	75,0	100,0	1475	147,0	485,7	2,5	7,4	0,7	2,1	3,1	94,0	93,9	93,2	0,85	1,06114	624	73
Q2EP280M4C		Cast Iron	90,0	125,0	1470	173,8	584,2	2,5	7,4	0,7	2,1	3,0	94,2	94,4	93,6	0,85	1,14768	638	73

ELECTRICAL CHARACTERISTICS AT 50 Hz

Motor Type	Housing Type	Rated Values					Starting Values					Breakdown Torque Ratio Mk/Mn	Efficiency*			Cos φ	J kgm ²	Weight (B3) kg	Sound Pressure Level dBA**
		Power		Speed	Current	Torque	Current		Torque		η%		4/4	2/4					
		kW	HP	d/d	A	Nm	I _A / A _N	Δ	M _A / M _N	Δ									
4pole1500d/d																			
400/690V	Q2EP315S4C	Cast Iron	110,0	127,0	1.480	191	709	2,4	7,2	0,7	2,2	2,5	94,5	94,5	93,9	0,88	3,03500	925	70
	Q2EP315M4C	Cast Iron	132,0	152,0	1.480	229	851	2,3	7,0	0,7	2,1	2,4	94,7	94,7	94,1	0,88	3,41500	1.010	70
	Q2EP315L4C	Cast Iron	160,0	184,0	1.480	273	1.032	2,5	7,5	0,7	2,2	2,5	94,9	94,9	94,3	0,89	4,11900	1.080	76
	Q2EP315L4D	Cast Iron	200,0	230,0	1.480	341	1.290	2,5	7,5	0,8	2,3	2,5	95,1	95,1	94,5	0,89	5,20300	1.200	76
	Q2EP355M4C	Cast Iron	250,0	280,0	1.485	426	1.607	2,6	7,9	0,8	2,3	2,5	95,1	95,1	94,5	0,89	8,79000	1.720	76
	Q2EP355L4C	Cast Iron	315,0	353,0	1.485	531	2.025	2,5	7,4	0,7	2,0	2,3	95,1	95,1	94,5	0,90	10,13300	1.920	87
	Q2EP355L4D	Cast Iron	355,0	398,0	1.485	605	2.283	2,9	8,8	0,6	1,8	2,0	95,1	95,1	94,5	0,89	10,67800	1.953	87
6pole1000d/d																			
220/380V	Q2E90L6C	Aluminum	0,75	1,0	940	2,6	7,7	4,0	-	2,3	-	2,5	75,9	74,7	73,2	0,68	0,00371	18	53
	Q2E90L6D	Aluminum	1,1	1,5	940	3,2	11,3	4,0	-	2,6	-	2,6	78,1	77,6	74,8	0,65	0,00444	20	53
	Q2E100L6D	Aluminum	1,5	2,0	940	4	15,3	4,5	-	2,4	-	2,7	79,8	79,3	76,4	0,71	0,00570	26	56
	Q2E112M6C	Aluminum	2,2	3,0	950	5,4	22,1	5,0	-	2,3	-	2,7	81,8	81,2	78,3	0,71	0,00916	31	58
380/600V	Q2E132M6A	Aluminum	3,0	4,0	945	7,3	29,8	1,7	5,2	1,0	3,0	3,0	83,3	82,3	79,4	0,64	0,02057	53	62
	Q2E132M6B	Aluminum	4,0	5,5	965	10,5	39,8	1,8	5,3	0,6	1,9	2,3	84,6	83,5	80,7	0,65	0,02070	54	62
	Q2E132M6C	Aluminum	5,5	7,5	945	13,1	54,7	1,6	4,9	0,8	2,4	2,6	86,1	85,7	83,9	0,76	0,02709	67	62
	Q2E160L6B	Aluminum	7,5	10,0	965	18,7	74,6	2,0	6,0	1,1	3,2	3,4	87,2	84,3	81,7	0,66	0,07040	94	63
	Q2E160L6C	Aluminum	11,0	15,0	960	25,1	109,4	1,6	4,9	0,9	2,7	2,8	88,7	88,5	86,3	0,74	0,07040	95,5	63
	Q2E180L6A	Aluminum	15,0	20,0	960	31,8	147,7	2,0	5,9	0,6	1,8	2,6	89,7	89,5	87,3	0,80	0,18369	115	64
	Q2E200L6B	Aluminum	18,5	25,0	970	38,0	182,2	1,8	5,5	0,5	1,6	2,4	90,4	90,2	89,6	0,83	0,27088	155	64
	Q2E200L6C	Aluminum	22,0	30,0	970	45,6	216,6	1,8	5,5	0,5	1,6	2,4	90,9	90,7	90,1	0,83	0,31281	165	64
	Q2E225M6B	Aluminum	30,0	40,0	980	60,9	287,6	1,8	5,4	0,5	1,6	2,3	91,7	91,6	90,7	0,82	0,49334	221	65

* According to IEC 60034-2-1

** The sound pressure measurement are taken 1 m away from the motor.

** Tolerance + 3 dBA

ELECTRICAL CHARACTERISTICS AT 50 Hz

Motor Type	Housing Type	Rated Values					Starting Values					Breakdown Torque Ratio Mk/Mn	Efficiency*			Cos φ	J kgm ²	Weight (B3) kg	Sound Pressure Level dBA**
		Power		Speed	Current	Torque	Current		Torque		η%		4/4	2/4					
		kW	HP	d/d	A	Nm	I _A / A _N	Δ	M _A / M _N	Δ									
2pole3000d/d																			
220/380V	Q2E71M2DE	Aluminum	0,75	1,0	2870	1,7	2,4	8,8	-	5,0	-	5,2	77,4	77,5	75,9	0,77	0,00110	11	56
	Q2E80M2DE	Aluminum	1,5	2,0	2875	3,0	5,0	8,1	-	4,0	-	4,3	81,5	82,0	80,9	0,76	0,00150	13	58
	Q2E90L2DE	Aluminum	3,0	4,0	2880	6,1	9,9	8,3	-	4,0	-	4,5	84,6	84,1	80,8	0,75	0,00182	18	62
380/660V	Q2E100L2DE	Aluminum	4,0	5,5	2900	7,9	13,3	3,0	9,3	1,4	4,3	5,2	85,9	86,0	84,1	0,77	0,00335	27	64
	Q2E112M2CE	Aluminum	5,5	7,5	2910	9,1	17,9	3,1	9,5	1,4	4,2	5,0	86,3	86,5	84,7	0,87	0,00489	31	67
	Q2E132M2AE	Aluminum	11,0	15,0	2923	13,6	24,5	2,9	9,0	1,2	3,6	4,0	88,3	87,9	86,1	0,89	0,01596	53	70
	Q2E160L2DE	Aluminum	22,0	30,0	2943	31,4	60,0	2,6	8,2	1,1	3,3	3,9	91,4	91,8	91,2	0,92	0,04075	92	71
	Q2EP250M2C	Cast Iron	75,0	100,0	2975	125,4	241,1	2,5	7,5	0,8	2,8	3,3	93,8	93,7	92,5	0,92	0,54033	576	84
	Q2EP280M2D	Cast Iron	110,0	150,0	2980	191,0	352,4	2,6	7,7	0,9	2,9	3,4	94,3	94,3	93,6	0,88	0,74111	640	84
4pole1500d/d																			
220/380V	Q2E80M4DE	Aluminum	1,1	1,5	1438	1,9	4,9	5,5	-	3,2	-	3,5	79,9	79,4	76,3	0,72	0,00268	12,5	49
	Q2E90L4DE	Aluminum	2,2	3,0	1440	4,8	14,5	7,5	-	3,5	-	4,0	84,3	83,5	80,6	0,70	0,00365	18	54
380/660V	Q2E112M4DE	Aluminum	5,5	7,5	1458	8,5	26,2	2,8	8,6	1,1	3,2	4,3	86,7	86,7	85,1	0,77	0,01123	34	58
	Q2EP250M4E	Cast Iron	75,0	100,0	1485	134,2	485,7	2,6	7,8	0,8	2,9	3,4	94,0	93,9	93,2	0,86	1,06114	624	73
	Q2EP280M4D	Cast Iron	110,0	150,0	1485	200,3	714,0	2,8	7,9	0,8	2,9	3,4	94,5	94,3	93,1	0,84	1,25586	654	73

* According to IEC 60034-2-1

** The sound pressure measurement are taken 1 m away from the motor.

** Tolerance + 3 dBA

DIMENSIONS - B3

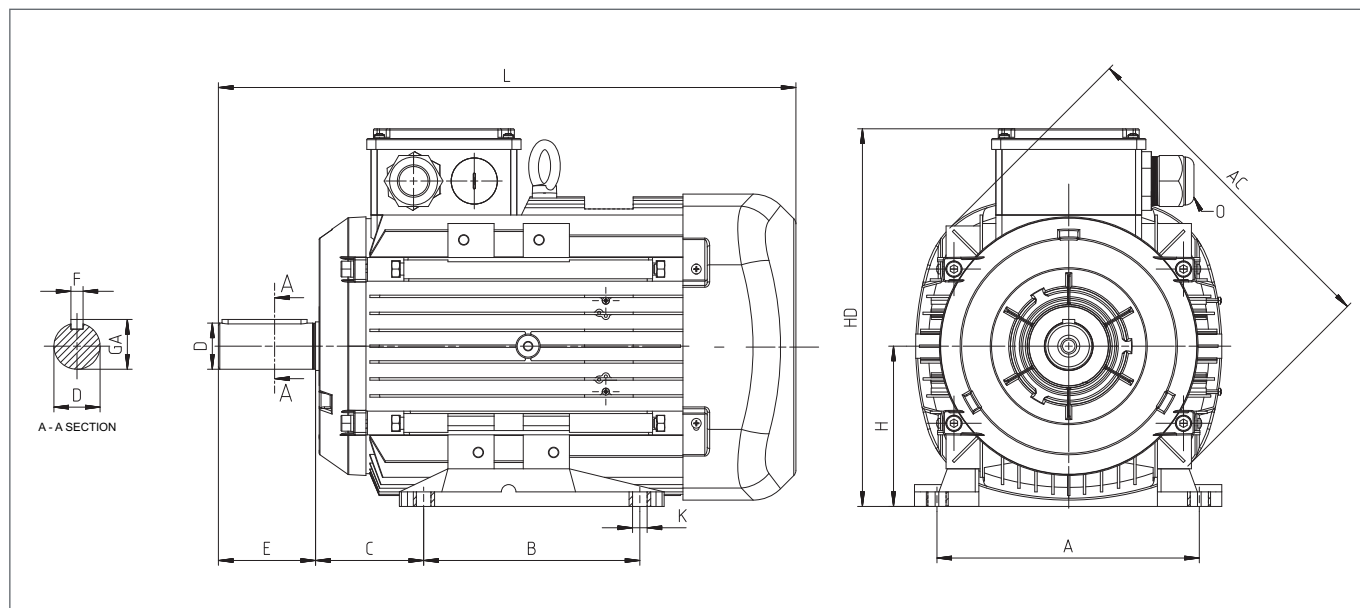

Power (kW)	Number of Poles	Motor Type	Housing Type	Main Dimensions			Foot Mounted Motors						Shaft			Bearing		Seal		
				AC	L	O	B	A	H	HD	K	C	D ⁽¹⁾	E	GA	F ⁽²⁾	Drive Side	Non Drive Side	Drive Side	Non Drive Side
0,25	4	Q2E71M4B	Aluminum	138	252,5	1*M20	90	112	71	190	7	45	14	30	16	5	6202-2Z	6202-2Z	15*24*5	15*24*5
	2	Q2E71M2C	Aluminum	138	252,5	1*M20	90	112	71	190	7	45	14	30	16	5	6202-2Z	6202-2Z	15*24*5	15*24*5
0,37	4	Q2E71M4B	Aluminum	138	252,5	1*M20	90	112	71	190	7	45	14	30	16	5	6202-2Z	6202-2Z	15*24*5	15*24*5
	2	Q2E71M2D	Aluminum	138	252,5	1*M20	90	112	71	190	7	45	14	30	16	5	6202-2Z	6202-2Z	15*24*5	15*24*5
0,55	4	Q2E80M4B	Aluminum	158	283,5	1*M20	100	125	80	195	10	50	19	40	21,5	6	6204-2Z	6204-2Z	20*30*7	20*30*7
	2	Q2E71M2DE	Aluminum	138	252,5	1*M20	90	112	71	190	7	45	14	30	16,0	5	6202-2Z	6202-2Z	15*24*5	15*24*5
0,75	2	Q2E80M2B	Aluminum	158	283,5	1*M20	100	125	80	195	10	50	19	40	21,5	6	6204-2Z	6204-2Z	20*30*7	20*30*7
	4	Q2E80M4D	Aluminum	158	283,5	1*M20	100	125	80	195	10	50	19	40	21,5	6	6204-2Z	6204-2Z	20*30*7	20*30*7
	6	Q2E90L6C	Aluminum	193	316,5	1*M25	100	140	90	222	10	56	24	50	27	8	6305-2Z	6205-2Z	25*40*7	25*40*7
1,1	2	Q2E80M2D	Aluminum	158	283,5	1*M20	100	125	80	195	10	50	19	40	21,5	6	6204-2Z	6204-2Z	20*30*7	20*30*7
	4	Q2E80M4DE	Aluminum	158	283,5	1*M20	100	125	80	195	10	50	19	40	21,5	6	6204-2Z	6204-2Z	20*30*7	20*30*7
	4	Q2E90L4C	Aluminum	193	316,5	1*M25	100	140	90	222	10	56	24	50	27	8	6305-2Z	6205-2Z	25*40*7	25*40*7
	6	Q2E90L6D	Aluminum	193	344,5	1*M25	125	140	90	222	10	56	24	50	27	8	6305-2Z	6205-2Z	25*40*7	25*40*7
1,5	2	Q2E80M2DE	Aluminum	158	283,5	1*M20	100	125	80	195	10	50	19	40	21,5	6	6204-2Z	6204-2Z	20*30*7	20*30*7
	2	Q2E90L2C	Aluminum	193	316,5	1*M25	100	140	90	222	10	56	24	50	27	8	6305-2Z	6205-2Z	25*40*7	25*40*7
	4	Q2E90L4D	Aluminum	193	316,5	1*M25	125	140	90	222	10	56	24	50	27	8	6305-2Z	6205-2Z	25*40*7	25*40*7
	6	Q2E100L6D	Aluminum	217	352,0	1*M25	140	160	100	241	12	63	28	60	31	8	6306-2Z	6205-2Z	30*47*7	25*40*7
2,2	2	Q2E90L2D	Aluminum	193	316,5	1*M25	125	140	90	222	10	56	24	50	27	8	6305-2Z	6205-2Z	25*40*7	25*40*7
	4	Q2E90L4DE	Aluminum	193	344,5	1*M25	125	140	90	222	10	56	24	50	27	8	6305-2Z	6205-2Z	25*40*7	25*40*7
	4	Q2E100L4C	Aluminum	217	352,0	1*M25	140	160	100	241	12	63	28	60	31	8	6306-2Z	6205-2Z	30*47*7	25*40*7
	6	Q2E112M6C	Aluminum	232	395,5	2*M25	140	190	112	261	12	70	28	60	31	8	6306-2Z	6206-2Z	30*47*7	30*47*7
3,0	2	Q2E90L2DE	Aluminum	193	316,5	1*M25	125	140	90	222	10	56	24	50	27	8	6305-2Z	6205-2Z	25*40*7	25*40*7
	2	Q2E100L2C	Aluminum	217	352,0	1*M25	140	160	100	241	12	63	28	60	31	8	6306-2Z	6205-2Z	30*47*7	25*40*7
	4	Q2E100L4D	Aluminum	217	352,0	1*M25	140	160	100	241	12	63	28	60	31	8	6306-2Z	6205-2Z	30*47*7	25*40*7
	6	Q2E132M6A	Aluminum	279	475,5	2*M32	140	216	132	314	12	89	38	80	41	10	6208-2Z	6208-2Z	40*62*10	40*62*10

DIMENSIONS - B3

Power (kW)	Number of Poles	Motor Type	Housing Type	Main Dimensions			Foot Mounted Motors						Shaft				Bearing		Seal	
				AC	L	O	B	A	H	HD	K	C	D ⁽¹⁾	E	GA	F ⁽²⁾	Drive Side	Non Drive Side	Drive Side	Non Drive Side
4,0	2	Q2E100L2DE	Aluminum	217	352,0	1*M25	140	160	100	241	12	63	28	60	31	8	6306-2Z	6205-2Z	30*47*7	25*40*7
	2	Q2E112M2C	Aluminum	232	395,5	2*M25	140	190	112	261	12	70	28	60	31	8	6306-2Z	6206-2Z	30*47*7	30*47*7
	4	Q2E112M4C	Aluminum	232	395,5	2*M25	140	190	112	261	12	70	28	60	31	8	6306-2Z	6206-2Z	30*47*7	30*47*7
	6	Q2E132M6B	Aluminum	279	475,5	2*M32	178	216	132	314	12	89	38	80	41	10	6208-2Z	6208-2Z	40*62*10	40*62*10
5,5	2	Q2E112M2CE	Aluminum	232	395,5	2*M25	140	190	112	261	12	70	28	60	31	8	6306-2Z	6206-2Z	30*47*7	30*47*7
	4	Q2E112M4D	Aluminum	232	395,5	2*M25	140	190	112	261	12	70	28	60	31	8	6306-2Z	6206-2Z	30*47*7	30*47*7
	2	Q2E132S2C	Aluminum	279	440,5	2*M32	140	216	132	314	12	89	38	80	41	10	6208-2Z	6208-2Z	40*62*10	40*62*10
	4	Q2E132M4B	Aluminum	279	475,5	2*M32	140	216	132	314	12	89	38	80	41	10	6208-2Z	6208-2Z	40*62*10	40*62*10
	6	Q2E132M6C	Aluminum	279	475,5	2*M32	178	216	132	314	12	89	38	80	41	10	6208-2Z	6208-2Z	40*62*10	40*62*10
7,5	2	Q2E132M2A	Aluminum	279	475,5	2*M32	140	216	132	314	12	89	38	80	41	10	6208-2Z	6208-2Z	40*62*10	40*62*10
	4	Q2E132M4C	Aluminum	279	475,5	2*M32	178	216	132	314	12	89	38	80	41	10	6208-2Z	6208-2Z	40*62*10	40*62*10
	6	Q2E160M6B	Aluminum	302	576,0	2*M32	210	254	160	360	15	108	42	110	45	12	6309-2Z	6209-2Z	45*72*10	45*72*10
11,0	2	Q2E132M2AE	Aluminum	279	475,5	2*M32	140	216	132	314	12	89	38	80	41	10	6208-2Z	6208-2Z	40*62*10	40*62*10
	2	Q2E160M2B	Aluminum	302	576,0	2*M32	210	254	160	360	15	108	42	110	45	12	6309-2Z	6209-2Z	45*72*10	45*72*10
	4	Q2E160M4B	Aluminum	302	576,0	2*M32	210	254	160	360	15	108	42	110	45	12	6309-2Z	6209-2Z	45*72*10	45*72*10
	6	Q2E160L6B	Aluminum	302	576,0	2*M32	254	254	160	360	15	108	42	110	45	12	6309-2Z	6209-2Z	45*72*10	45*72*10
15,0	2	Q2E160L2A	Aluminum	302	576,0	2*M32	210	254	160	360	15	108	42	110	45	12	6309-2Z	6209-2Z	45*72*10	45*72*10
	4	Q2E160L4A	Aluminum	302	576,0	2*M32	254	254	160	360	15	108	42	110	45	12	6309-2Z	6209-2Z	45*72*10	45*72*10
	6	Q2E180L6A	Aluminum	370	629,0	2*M40	279	279	180	428	15	121	48	110	51,5	14	6310-2Z	6310-2Z	50*80*10	50*80*10
18,5	2	Q2E160L2C	Aluminum	302	576,0	2*M32	254	254	160	360	15	108	42	110	45	12	6309-2Z	6209-2Z	45*72*10	45*72*10
	4	Q2E180M4B	Aluminum	370	629,0	2*M40	241	279	180	428	15	121	48	110	51,5	14	6310-2Z	6310-2Z	50*80*10	50*80*10
	6	Q2E200L6B	Aluminum	415	665,0	2*M50	305	318	200	461	19	133	55	110	59	16	6312-2Z	6312-2Z	60*90*10	60*90*10
22,0	2	Q2E160L2D	Aluminum	302	576,0	2*M32	210	254	160	360	15	108	42	110	45	12	6309-2Z	6209-2Z	45*72*10	45*72*10
	2	Q2E180M2A	Aluminum	370	629,0	2*M40	241	279	180	428	15	121	48	110	51,5	14	6310-2Z	6310-2Z	50*80*10	50*80*10
	4	Q2E180L4B	Aluminum	370	629,0	2*M40	279	279	180	428	15	121	48	110	51,5	14	6310-2Z	6310-2Z	50*80*10	50*80*10
	6	Q2E200L6C	Aluminum	415	665,0	2*M50	305	318	200	461	19	133	55	110	59	16	6312-2Z	6312-2Z	60*90*10	60*90*10
	2	Q2E200L2B	Aluminum	415	665,0	2*M50	305	318	200	461	19	133	55	110	59	16	6312-2Z	6312-2Z	60*90*10	60*90*10
30,0	4	Q2E200L4D	Aluminum	415	665,0	2*M50	305	318	200	461	19	133	55	110	59	16	6312-2Z	6312-2Z	60*90*10	60*90*10
	6	Q2E225M6B	Aluminum	456	765,0	2*M50	311	356	225	504	19	149	60	140	64	18	6313-2Z	6313-2Z	65*100*13	65*100*13
	2	Q2E200L2C	Aluminum	415	665,0	2*M50	305	318	200	461	19	133	55	110	59	16	6312-2Z	6312-2Z	60*90*10	60*90*10
37,0	4	Q2E225M4C	Aluminum	456	765,0	2*M50	286	356	225	504	19	149	60	140	64	18	6313-2Z	6313-2Z	65*100*13	65*100*13
	2	Q2E225M2B	Aluminum	456	735,0	2*M50	311	356	225	504	19	149	55	110	59	16	6313-2Z	6313-2Z	65*100*13	65*100*13
45,0	4	Q2E225M4D	Aluminum	456	765,0	2*M50	311	356	225	504	19	149	60	140	64	18	6313-2Z	6313-2Z	65*100*13	65*100*13
	2	Q2EP250M2B	Cast Iron	527	886,0	2*M50	349	406	250	615	24	168	60	140	64	18	6316	6316	80*100*10	80*100*10
55,0	4	Q2EP250M4D	Cast Iron	527	886,0	2*M50	349	406	250	615	24	168	65	140	69	18	6316	6316	80*100*10	80*100*10
	2	Q2EP250M2C	Cast Iron	527	886,0	2*M50	349	406	250	615	24	168	60	140	64	18	6316	6316	80*100*10	80*100*10
	2	Q2EP280M2B	Cast Iron	527	1025,0	2*M50	419	457	280	647	24	190	65	140	69	18	6316	6316	80*100*10	80*100*10
	4	Q2EP250M4E	Cast Iron	527	886,0	2*M50	349	406	250	615	24	168	65	140	69	18	6316	6316	80*100*10	80*100*10
	4	Q2EP280M4B	Cast Iron	527	1025,0	2*M50	419	457	280	647	24	190	75	140	80	20	6316	6316	80*100*10	80*100*10
90,0	2	Q2EP280M2C	Cast Iron	527	1025,0	2*M50	419	457	280	647	24	190	65	140	69	18	6316	6316	80*100*10	80*100*10
	4	Q2EP280M4C	Cast Iron	527	1025,0	2*M50	419	457	280	647	24	190	75	140	80	20	6316	6316	80*100*10	80*100*10
110,0	2	Q2EP280M2D	Cast Iron	527	1025,0	2*M50	419	457	280	647	24	190	65	140	69	18	6316	6316	80*100*10	80*100*10
	4	Q2EP280M4D	Cast Iron	527	1025,0	2*M50	419	457	280	647	24	190	75	140	80	20	6316	6316	80*100*10	80*100*10

DIMENSIONS - B3

Power (kW)	Number of Poles	Motor Type	Housing Type	Main Dimensions			Foot Mounted Motors						Shaft				Bearing		Seal	
				AC	L	O	B	A	H	HD	K	C	D ⁽¹⁾	E	GA	F ⁽²⁾	Drive Side	Non Drive Side	Drive Side	Non Drive Side
110,0	2	Q2EP315S2C	Cast Iron	630	1180,0	2*M63	406	508	315	845	28	216	65	140	69	18	6317	6317	85*105*5.5	85*105*5.5
	4	Q2EP315S4C	Cast Iron	630	1210,0	2*M63	406	508	315	845	28	216	80	170	85	22	6319	6319	95*115*5.5	95*115*5.5
132,0	2	Q2EP315M2C	Cast Iron	630	1290,0	2*M63	457	508	315	845	28	216	65	140	69	18	6317	6317	85*105*5.5	85*105*5.5
	4	Q2EP315M4C	Cast Iron	630	1320,0	2*M63	457	508	315	845	28	216	80	170	85	22	6319	6319	95*115*5.5	95*115*5.5
160,0	2	Q2EP315L2C	Cast Iron	630	1290,0	2*M63	508	508	315	845	28	216	65	140	69	18	6317	6317	85*105*5.5	85*105*5.5
	4	Q2EP315L4C	Cast Iron	630	1320,0	2*M63	508	508	315	845	28	216	80	170	85	22	6319	6319	95*115*5.5	95*115*5.5
200,0	2	Q2EP315L2D	Cast Iron	630	1290,0	2*M63	508	508	315	845	28	216	65	140	69	18	6317	6317	85*105*5.5	85*105*5.5
	4	Q2EP315L4D	Cast Iron	630	1320,0	2*M63	508	508	315	845	28	216	80	170	85	22	6319	6319	95*115*5.5	95*115*5.5
250,0	2	Q2EP355M2C	Cast Iron	710	1486,0	4*M63	560	610	355	956	28	254	75	140	80	20	6317	6317	85*105*5.5	85*105*5.5
	4	Q2EP355M4C	Cast Iron	710	1517,0	4*M63	560	610	355	956	28	254	95	170	100	25	6322	6322	110*130*5.5	110*130*5.5
315,0	2	Q2EP355L2C	Cast Iron	710	1486,0	4*M63	630	610	355	956	28	254	75	140	80	20	6317	6317	85*105*5.5	85*105*5.5
	4	Q2EP355L4C	Cast Iron	710	1517,0	4*M63	630	610	355	956	28	254	95	170	100	25	6322	6322	110*130*5.5	110*130*5.5
355,0	2	Q2EP355L2D	Cast Iron	710	1486,0	4*M63	630	610	355	956	28	254	75	140	80	20	6317	6317	85*105*5.5	85*105*5.5
	4	Q2EP355L4D	Cast Iron	710	1517,0	4*M63	630	610	355	956	28	254	95	170	100	25	6322	6322	110*130*5.5	110*130*5.5

(1) Tolerance DIN EN 50347 "j6" up to 28 mm "k6" above 28 mm

(2) According to DIN 6885

DIMENSIONS - B5, B35

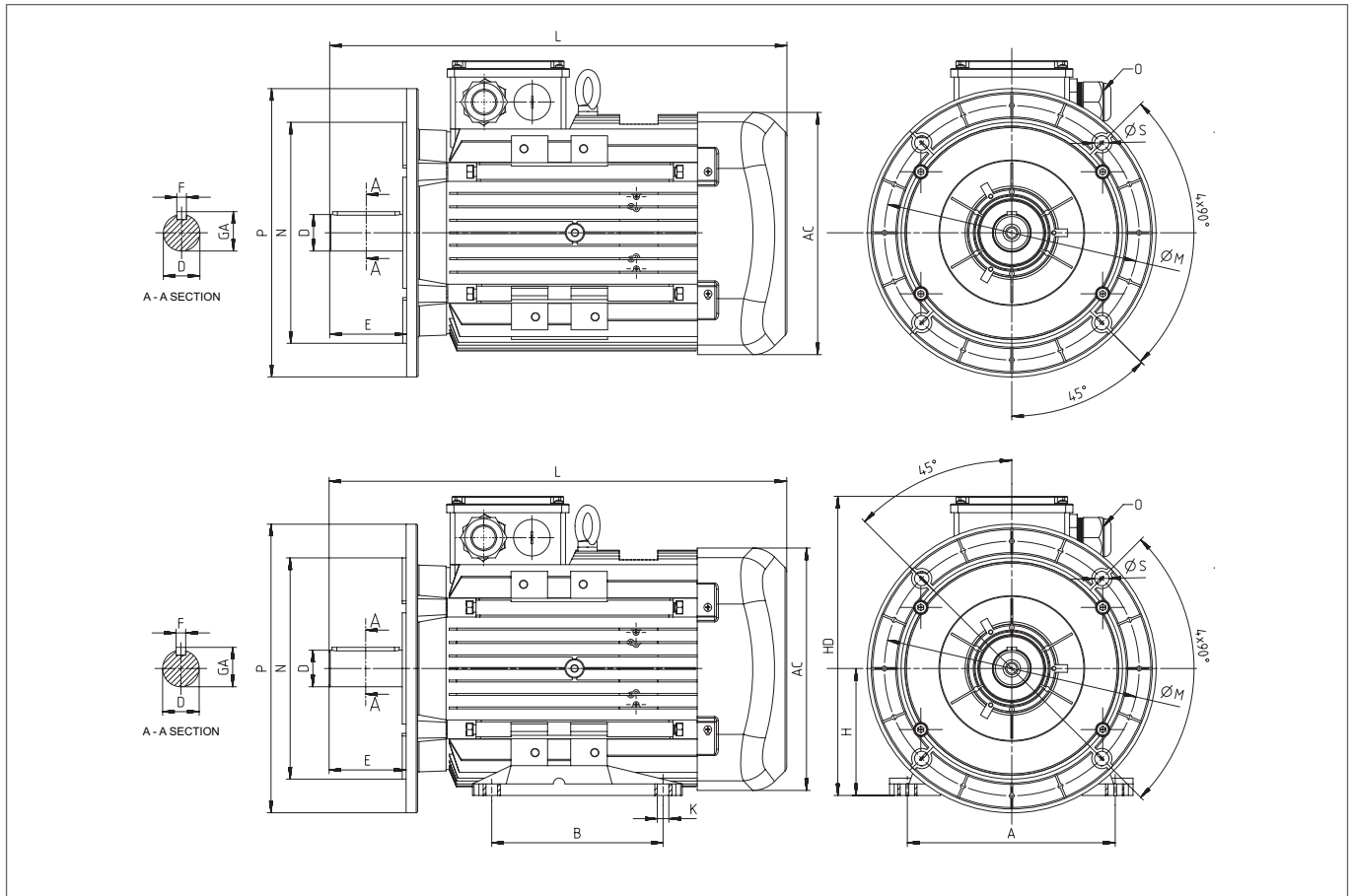

Power (kW)	Number of Poles	Motor Type	Housing Type	Main Dimensions			Foot Mounted Motors				Shaft			Bearing		Seal		Flange (FA) (B5)						
				AC	L	O	B	A	H	HD	K	D ⁽¹⁾	E	GA	F ⁽²⁾	Drive Side	Non Drive Side	Drive Side	Non Drive Side	P	N ⁽³⁾	M	R	S
0,25	4	Q2E71M4B	Aluminum	138	252,5	1*M20	90	112	71	190	7	14	30	16	5	6202-2Z	6202-2Z	15*24*5	15*24*5	160	110	130	0	10
0,37	2	Q2E71M2C	Aluminum	138	252,5	1*M20	90	112	71	190	7	14	30	16	5	6202-2Z	6202-2Z	15*24*5	15*24*5	160	110	130	0	10
	4	Q2E71M4B	Aluminum	138	252,5	1*M20	90	112	71	190	7	14	30	16	5	6202-2Z	6202-2Z	15*24*5	15*24*5	160	110	130	0	10
0,55	2	Q2E71M2D	Aluminum	138	252,5	1*M20	90	112	71	190	7	14	30	16	5	6202-2Z	6202-2Z	15*24*5	15*24*5	160	110	130	0	10
	4	Q2E80M4B	Aluminum	158	283,5	1*M20	100	125	80	195	10	19	40	21,5	6	6204-2Z	6204-2Z	20*30*7	20*30*7	200	130	165	0	12
0,75	2	Q2E71M2DE	Aluminum	138	252,5	1*M20	90	112	71	190	7	14	30	16,0	5	6202-2Z	6202-2Z	15*24*5	15*24*5	160	110	130	0	10
	2	Q2E80M2B	Aluminum	158	283,5	1*M20	100	125	80	195	10	19	40	21,5	6	6204-2Z	6204-2Z	20*30*7	20*30*7	200	130	165	0	12
	4	Q2E80M4D	Aluminum	158	283,5	1*M20	100	125	80	195	10	19	40	21,5	6	6204-2Z	6204-2Z	20*30*7	20*30*7	200	130	165	0	12
1,1	6	Q2E90L6C	Aluminum	193	316,5	1*M25	100	140	90	222	10	24	50	27	8	6305-2Z	6205-2Z	25*40*7	25*40*7	200	130	165	0	12
	2	Q2E80M2D	Aluminum	158	283,5	1*M20	100	125	80	195	10	19	40	21,5	6	6204-2Z	6204-2Z	20*30*7	20*30*7	200	130	165	0	12
	4	Q2E80M4DE	Aluminum	158	283,5	1*M20	100	125	80	195	10	19	40	21,5	6	6204-2Z	6204-2Z	20*30*7	20*30*7	200	130	165	0	12
	4	Q2E90L4C	Aluminum	193	316,5	1*M25	100	140	90	222	10	24	50	27	8	6305-2Z	6205-2Z	25*40*7	25*40*7	200	130	165	0	12
1,5	6	Q2E90L6D	Aluminum	193	344,5	1*M25	125	140	90	222	10	24	50	27	8	6305-2Z	6205-2Z	25*40*7	25*40*7	200	130	165	0	12
	2	Q2E80M2DE	Aluminum	158	283,5	1*M20	100	125	80	195	10	19	40	21,5	6	6204-2Z	6204-2Z	20*30*7	20*30*7	200	130	165	0	12
	2	Q2E90L2C	Aluminum	193	316,5	1*M25	100	140	90	222	10	24	50	27	8	6305-2Z	6205-2Z	25*40*7	25*40*7	200	130	165	0	12
2,2	4	Q2E90L4D	Aluminum	193	316,5	1*M25	125	140	90	222	10	24	50	27	8	6305-2Z	6205-2Z	25*40*7	25*40*7	200	130	165	0	12
	6	Q2E100L6D	Aluminum	217	352,0	1*M25	140	160	100	241	12	28	60	31	8	6306-2Z	6205-2Z	30*47*7	25*40*7	250	180	215	0	15
	2	Q2E90L2D	Aluminum	193	316,5	1*M25	125	140	90	222	10	24	50	27	8	6305-2Z	6205-2Z	25*40*7	25*40*7	200	130	165	0	12
	4	Q2E90L4DE	Aluminum	193	344,5	1*M25	125	140	90	222	10	24	50	27	8	6305-2Z	6205-2Z	25*40*7	25*40*7	200	130	165	0	12
3,0	4	Q2E100L4C	Aluminum	217	352,0	1*M25	140	160	100	241	12	28	60	31	8	6306-2Z	6205-2Z	30*47*7	25*40*7	250	180	215	0	15
	6	Q2E112M6C	Aluminum	232	395,5	2*M25	140	190	112	261	12	28	60	31	8	6306-2Z	6206-2Z	30*47*7	30*47*7	250	180	215	0	15
	2	Q2E90L2DE	Aluminum	193	316,5	1*M25	125	140	90	222	10	24	50	27	8	6305-2Z	6205-2Z	25*40*7	25*40*7	200	130	165	0	12
	2	Q2E100L2C	Aluminum	217	352,0	1*M25	140	160	100	241	12	28	60	31	8	6306-2Z	6205-2Z	30*47*7	25*40*7	250	180	215	0	15
	4	Q2E100L4D	Aluminum	217	352,0	1*M25	140	160	100	241	12	28	60	31	8	6306-2Z	6205-2Z	30*47*7	25*40*7	250	180	215	0	15
	6	Q2E132M6A	Aluminum	279	475,5	2*M32	140	216	132	314	12	38	80	41	10	6208-2Z	6208-2Z	40*62*10	40*62*10	300	230	265	0	15

DIMENSIONS - B5, B35

Power (kW)	Number of Poles	Motor Type	Housing Type	Main Dimensions			Foot Mounted Motors						Shaft				Bearing		Seal		Flange (FA) (B5)				
				AC	L	O	B	A	H	HD	K	D ⁽¹⁾	E	GA	F ⁽²⁾	Drive Side	Non Drive Side	Drive Side	Non Drive Side	P	N ⁽³⁾	M	R	S	
4,0	2	Q2E100L2DE	Aluminum	217	352,0	1*M25	140	160	100	241	12	28	60	31	8	6306-2Z	6205-2Z	30*47*7	25*40*7	250	180	215	0	15	
	2	Q2E112M2C	Aluminum	232	395,5	2*M25	140	190	112	261	12	28	60	31	8	6306-2Z	6206-2Z	30*47*7	30*47*7	250	180	215	0	15	
	4	Q2E112M4C	Aluminum	232	395,5	2*M25	140	190	112	261	12	28	60	31	8	6306-2Z	6206-2Z	30*47*7	30*47*7	250	180	215	0	15	
	6	Q2E132M6B	Aluminum	279	475,5	2*M32	178	216	132	314	12	38	80	41	10	6208-2Z	6208-2Z	40*62*10	40*62*10	300	230	265	0	15	
5,5	2	Q2E112M2CE	Aluminum	232	395,5	2*M25	140	190	112	261	12	28	60	31	8	6306-2Z	6206-2Z	30*47*7	30*47*7	250	180	215	0	15	
	4	Q2E112M4D	Aluminum	232	395,5	2*M25	140	190	112	261	12	28	60	31	8	6306-2Z	6206-2Z	30*47*7	30*47*7	250	180	215	0	15	
	2	Q2E132S2C	Aluminum	279	440,5	2*M32	140	216	132	314	12	38	80	41	10	6208-2Z	6208-2Z	40*62*10	40*62*10	300	230	265	0	15	
	4	Q2E132M4B	Aluminum	279	475,5	2*M32	140	216	132	314	12	38	80	41	10	6208-2Z	6208-2Z	40*62*10	40*62*10	300	230	265	0	15	
7,5	6	Q2E132M6C	Aluminum	279	475,5	2*M32	178	216	132	314	12	38	80	41	10	6208-2Z	6208-2Z	40*62*10	40*62*10	300	230	265	0	15	
	2	Q2E132M2A	Aluminum	279	475,5	2*M32	140	216	132	314	12	38	80	41	10	6208-2Z	6208-2Z	40*62*10	40*62*10	300	230	265	0	15	
	4	Q2E132M4C	Aluminum	279	475,5	2*M32	178	216	132	314	12	38	80	41	10	6208-2Z	6208-2Z	40*62*10	40*62*10	300	230	265	0	15	
11,0	6	Q2E160M6B	Aluminum	302	576,0	2*M32	210	254	160	360	15	42	110	45	12	6309-2Z	6209-2Z	45*72*10	45*72*10	350	250	300	0	19	
	2	Q2E132M2AE	Aluminum	279	475,5	2*M32	140	216	132	314	12	38	80	41	10	6208-2Z	6208-2Z	40*62*10	40*62*10	300	230	265	0	15	
	2	Q2E160M2B	Aluminum	302	576,0	2*M32	210	254	160	360	15	42	110	45	12	6309-2Z	6209-2Z	45*72*10	45*72*10	350	250	300	0	19	
	4	Q2E160M4B	Aluminum	302	576,0	2*M32	210	254	160	360	15	42	110	45	12	6309-2Z	6209-2Z	45*72*10	45*72*10	350	250	300	0	19	
15,0	6	Q2E160L6B	Aluminum	302	576,0	2*M32	254	254	160	360	15	42	110	45	12	6309-2Z	6209-2Z	45*72*10	45*72*10	350	250	300	0	19	
	2	Q2E160L2A	Aluminum	302	576,0	2*M32	210	254	160	360	15	42	110	45	12	6309-2Z	6209-2Z	45*72*10	45*72*10	350	250	300	0	19	
	4	Q2E160L4A	Aluminum	302	576,0	2*M32	254	254	160	360	15	42	110	45	12	6309-2Z	6209-2Z	45*72*10	45*72*10	350	250	300	0	19	
18,5	6	Q2E180L6A	Aluminum	370	629,0	2*M40	279	279	180	428	15	48	110	51,5	14	6310-2Z	6310-2Z	50*80*10	50*80*10	350	250	300	0	19	
	2	Q2E160L2C	Aluminum	302	576,0	2*M32	254	254	160	360	15	42	110	45	12	6309-2Z	6209-2Z	45*72*10	45*72*10	350	250	300	0	19	
	4	Q2E180M4B	Aluminum	370	629,0	2*M40	241	279	180	428	15	48	110	51,5	14	6310-2Z	6310-2Z	50*80*10	50*80*10	350	250	300	0	19	
22,0	6	Q2E200L6C	Aluminum	415	665,0	2*M50	305	318	200	461	19	55	110	59	16	6312-2Z	6312-2Z	60*90*10	60*90*10	400	300	350	0	19	
	2	Q2E160L2D	Aluminum	302	576,0	2*M32	210	254	160	360	15	42	110	45	12	6309-2Z	6209-2Z	45*72*10	45*72*10	350	250	300	0	19	
	2	Q2E180M2A	Aluminum	370	629,0	2*M40	241	279	180	428	15	48	110	51,5	14	6310-2Z	6310-2Z	50*80*10	50*80*10	350	250	300	0	19	
	4	Q2E180L4B	Aluminum	370	629,0	2*M40	279	279	180	428	15	48	110	51,5	14	6310-2Z	6310-2Z	50*80*10	50*80*10	350	250	300	0	19	
30,0	6	Q2E200L6C	Aluminum	415	665,0	2*M50	305	318	200	461	19	55	110	59	16	6312-2Z	6312-2Z	60*90*10	60*90*10	400	300	350	0	19	
	2	Q2E200L2B	Aluminum	415	665,0	2*M50	305	318	200	461	19	55	110	59	16	6312-2Z	6312-2Z	60*90*10	60*90*10	400	300	350	0	19	
	4	Q2E200L4D	Aluminum	415	665,0	2*M50	305	318	200	461	19	55	110	59	16	6312-2Z	6312-2Z	60*90*10	60*90*10	400	300	350	0	19	
37,0	6	Q2E225M6B	Aluminum	456	765,0	2*M50	311	356	225	504	19	60	140	64	18	6313-2Z	6313-2Z	65*100*13	65*100*13	450	350	400	0	19	
	2	Q2E200L2C	Aluminum	415	665,0	2*M50	305	318	200	461	19	55	110	59	16	6312-2Z	6312-2Z	60*90*10	60*90*10	400	300	350	0	19	
45,0	4	Q2E225M4C	Aluminum	456	765,0	2*M50	286	356	225	504	19	60	140	64	18	6313-2Z	6313-2Z	65*100*13	65*100*13	450	350	400	0	19	
	2	Q2E225M2B	Aluminum	456	735,0	2*M50	311	356	225	504	19	55	110	59	16	6313-2Z	6313-2Z	65*100*13	65*100*13	450	350	400	0	19	
55,0	4	Q2E225M4D	Aluminum	456	765,0	2*M50	311	356	225	504	19	60	140	64	18	6313-2Z	6313-2Z	65*100*13	65*100*13	450	350	400	0	19	
	2	Q2EP250M2B	Cast Iron	527	886,0	2*M50	349	406	250	615	24	60	140	64	18	6316	6316	80*100*10	80*100*10	550	450	500	0	19	
75,0	4	Q2EP250M4D	Cast Iron	527	886,0	2*M50	349	406	250	615	24	65	140	69	18	6316	6316	80*100*10	80*100*10	550	450	500	0	19	
	2	Q2EP250M2C	Cast Iron	527	886,0	2*M50	349	406	250	615	24	60	140	64	18	6316	6316	80*100*10	80*100*10	550	450	500	0	19	
	2	Q2EP280M2B	Cast Iron	527	1025,0	2*M50	419	457	280	647	24	65	140	69	18	6316	6316	80*100*10	80*100*10	550	450	500	0	19	
	4	Q2EP250M4E	Cast Iron	527	886,0	2*M50	349	406	250	615	24	65	140	69	18	6316	6316	80*100*10	80*100*10	550	450	500	0	19	
90,0	4	Q2EP280M4B	Cast Iron	527	1025,0	2*M50	419	457	280	647	24	75	140	80	20	6316	6316	80*100*10	80*100*10	550	450	500	0	19	
	2	Q2EP280M2C	Cast Iron	527	1025,0	2*M50	419	457	280	647	24	65	140	69	18	6316	6316	80*100*10	80*100*10	550	450	500	0	19	
110,0	4	Q2EP280M4C	Cast Iron	527	1025,0	2*M50	419	457	280	647	24	75	140	80	20	6316	6316	80*100*10	80*100*10	550	450	500	0	19	
	2	Q2EP280M2D	Cast Iron	527	1025,0	2*M50	419	457	280	647	24	65	140	69	18	6316	6316	80*100*10	80*100*10	550	450	500	0	19	

DIMENSIONS - B5, B35

Power (kW)	Number of Poles	Motor Type	Housing Type	Main Dimensions			Foot Mounted Motors						Shaft				Bearing		Seal		Flange (FA) (B5)				
				AC	L	O	B	A	H	HD	K	C	D ⁽¹⁾	E	GA	F ⁽²⁾	Drive Side	Non Drive Side	Drive Side	Non Drive Side	P	N ⁽³⁾	M	R	S
110,0	2	Q2EP315S2C	Cast Iron	630	1180,0	2*M63	406	508	315	845	28	216	65	140	69	18	6317	6317	85*105*5.5	85*105*5.5	660	550	600	0	24
	4	Q2EP315S4C	Cast Iron	630	1210,0	2*M63	406	508	315	845	28	216	80	170	85	22	6319	6319	95*115*5.5	95*115*5.5	660	550	600	0	24
132,0	2	Q2EP315M2C	Cast Iron	630	1290,0	2*M63	457	508	315	845	28	216	65	140	69	18	6317	6317	85*105*5.5	85*105*5.5	660	550	600	0	24
	4	Q2EP315M4C	Cast Iron	630	1320,0	2*M63	457	508	315	845	28	216	80	170	85	22	6319	6319	95*115*5.5	95*115*5.5	660	550	600	0	24
160,0	2	Q2EP315L2C	Cast Iron	630	1290,0	2*M63	508	508	315	845	28	216	65	140	69	18	6317	6317	85*105*5.5	85*105*5.5	660	550	600	0	24
	4	Q2EP315L4C	Cast Iron	630	1320,0	2*M63	508	508	315	845	28	216	80	170	85	22	6319	6319	95*115*5.5	95*115*5.5	660	550	600	0	24
200,0	2	Q2EP315L2D	Cast Iron	630	1290,0	2*M63	508	508	315	845	28	216	65	140	69	18	6317	6317	85*105*5.5	85*105*5.5	660	550	600	0	24
	4	Q2EP315L4D	Cast Iron	630	1320,0	2*M63	508	508	315	845	28	216	80	170	85	22	6319	6319	95*115*5.5	95*115*5.5	660	550	600	0	24
250,0	2	Q2EP355M2C	Cast Iron	710	1486,0	4*M63	560	610	355	956	28	254	75	140	80	20	6317	6317	85*105*5.5	85*105*5.5	800	680	740	0	24
	4	Q2EP355M4C	Cast Iron	710	1517,0	4*M63	560	610	355	956	28	254	95	170	100	25	6322	6322	110*130*5.5	110*130*5.5	800	680	740	0	24
315,0	2	Q2EP355L2C	Cast Iron	710	1486,0	4*M63	630	610	355	956	28	254	75	140	80	20	6317	6317	85*105*5.5	85*105*5.5	800	680	740	0	24
	4	Q2EP355L4C	Cast Iron	710	1517,0	4*M63	630	610	355	956	28	254	95	170	100	25	6322	6322	110*130*5.5	110*130*5.5	800	680	740	0	24
355,0	2	Q2EP355L2D	Cast Iron	710	1486,0	4*M63	630	610	355	956	28	254	75	140	80	20	6317	6317	85*105*5.5	85*105*5.5	800	680	740	0	24
	4	Q2EP355L4D	Cast Iron	710	1517,0	4*M63	630	610	355	956	28	254	95	170	100	25	6322	6322	110*130*5.5	110*130*5.5	800	680	740	0	24

(1) Tolerance DIN EN 50347 "j6" up to 28 mm "k6" above 28 mm

(2) According to DIN 6885

(3) Tolerance DIN EN 50347 "j6"

DIMENSIONS - B14a, B34a

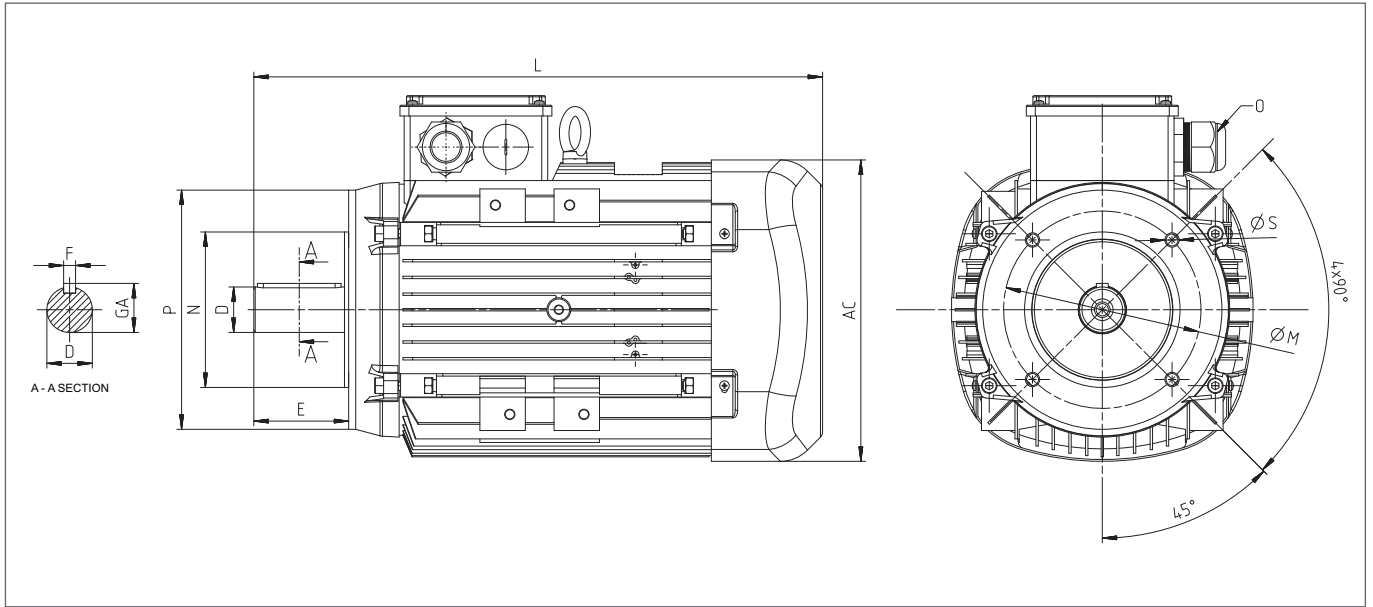

Power (kW)	Number of Poles	Motor Type	Housing Type	Main Dimensions			Foot Mounted Motors					Shaft				Bearing		Seal		Flange (FC) (B14a)				
				AC	L	O	B	A	H	HD	K	D ⁽¹⁾	E	GA	F ⁽²⁾	Drive Side	Non Drive Side	Drive Side	Non Drive Side	P	N ⁽³⁾	M	R	S
0,25	4	Q2E71M4B	Aluminum	138	252,5	1*M20	90	112	71	190	7	14	30	16	5	6202-2Z	6202-2Z	15*24*5	15*24*5	105	70	85	0	M6
	2	Q2E71M2C	Aluminum	138	252,5	1*M20	90	112	71	190	7	14	30	16	5	6202-2Z	6202-2Z	15*24*5	15*24*5	105	70	85	0	M6
0,37	4	Q2E71M4B	Aluminum	138	252,5	1*M20	90	112	71	190	7	14	30	16	5	6202-2Z	6202-2Z	15*24*5	15*24*5	105	70	85	0	M6
	2	Q2E71M2D	Aluminum	138	252,5	1*M20	90	112	71	190	7	14	30	16	5	6202-2Z	6202-2Z	15*24*5	15*24*5	105	70	85	0	M6
0,55	4	Q2E80M4B	Aluminum	158	283,5	1*M20	100	125	80	195	10	19	40	21,5	6	6204-2Z	6204-2Z	20*30*7	20*30*7	120	80	100	0	M6
	2	Q2E71M2DE	Aluminum	138	252,5	1*M20	90	112	71	190	7	14	30	16,0	5	6202-2Z	6202-2Z	15*24*5	15*24*5	105	70	85	0	M6
0,75	2	Q2E80M2B	Aluminum	158	283,5	1*M20	100	125	80	195	10	19	40	21,5	6	6204-2Z	6204-2Z	20*30*7	20*30*7	120	80	100	0	M6
	4	Q2E80M4D	Aluminum	158	283,5	1*M20	100	125	80	195	10	19	40	21,5	6	6204-2Z	6204-2Z	20*30*7	20*30*7	120	80	100	0	M6
1,1	6	Q2E90L6C	Aluminum	193	316,5	1*M25	100	140	90	222	10	24	50	27	8	6305-2Z	6205-2Z	25*40*7	25*40*7	140	95	115	0	M8
	2	Q2E80M2D	Aluminum	158	283,5	1*M20	100	125	80	195	10	19	40	21,5	6	6204-2Z	6204-2Z	20*30*7	20*30*7	120	80	100	0	M6
	4	Q2E80M4DE	Aluminum	158	283,5	1*M20	100	125	80	195	10	19	40	21,5	6	6204-2Z	6204-2Z	20*30*7	20*30*7	120	80	100	0	M6
	6	Q2E90L6D	Aluminum	193	316,5	1*M25	100	140	90	222	10	24	50	27	8	6305-2Z	6205-2Z	25*40*7	25*40*7	140	95	115	0	M8
1,5	6	Q2E90L6D	Aluminum	193	344,5	1*M25	125	140	90	222	10	24	50	27	8	6305-2Z	6205-2Z	25*40*7	25*40*7	140	95	115	0	M8
	2	Q2E80M2DE	Aluminum	158	283,5	1*M20	100	125	80	195	10	19	40	21,5	6	6204-2Z	6204-2Z	20*30*7	20*30*7	120	80	100	0	M6
	2	Q2E90L2C	Aluminum	193	316,5	1*M25	100	140	90	222	10	24	50	27	8	6305-2Z	6205-2Z	25*40*7	25*40*7	140	95	115	0	M8
2,2	4	Q2E90L4D	Aluminum	193	316,5	1*M25	125	140	90	222	10	24	50	27	8	6305-2Z	6205-2Z	25*40*7	25*40*7	140	95	115	0	M8
	4	Q2E100L6D	Aluminum	217	352,0	1*M25	140	160	100	241	12	28	60	31	8	6306-2Z	6205-2Z	30*47*7	25*40*7	160	110	130	0	M8
	6	Q2E112M6C	Aluminum	232	395,5	2*M25	140	190	112	261	12	28	60	31	8	6306-2Z	6206-2Z	30*47*7	30*47*7	160	110	130	0	M8
	4	Q2E100L4C	Aluminum	217	352,0	1*M25	140	160	100	241	12	28	60	31	8	6306-2Z	6205-2Z	30*47*7	25*40*7	160	110	130	0	M8
3,0	6	Q2E112M6C	Aluminum	232	395,5	2*M25	140	190	112	261	12	28	60	31	8	6306-2Z	6206-2Z	30*47*7	30*47*7	160	110	130	0	M8
	2	Q2E90L2DE	Aluminum	193	316,5	1*M25	125	140	90	222	10	24	50	27	8	6305-2Z	6205-2Z	25*40*7	25*40*7	140	95	115	0	M8
	2	Q2E100L2C	Aluminum	217	352,0	1*M25	140	160	100	241	12	28	60	31	8	6306-2Z	6205-2Z	30*47*7	25*40*7	160	110	130	0	M8
	4	Q2E100L4D	Aluminum	217	352,0	1*M25	140	160	100	241	12	28	60	31	8	6306-2Z	6205-2Z	30*47*7	25*40*7	160	110	130	0	M8
4,0	6	Q2E132M6A	Aluminum	279	475,5	2*M32	140	216	132	314	12	38	80	41	10	6208-2Z	6208-2Z	40*62*10	40*62*10	200	130	165	0	M10
	2	Q2E100L2DE	Aluminum	217	352,0	1*M25	140	160	100	241	12	28	60	31	8	6306-2Z	6205-2Z	30*47*7	25*40*7	160	110	130	0	M8
	2	Q2E112M2C	Aluminum	232	395,5	2*M25	140	190	112	261	12	28	60	31	8	6306-2Z	6206-2Z	30*47*7	30*47*7	160	110	130	0	M8
	4	Q2E112M4C	Aluminum	232	395,5	2*M25	140	190	112	261	12	28	60	31	8	6306-2Z	6206-2Z	30*47*7	30*47*7	160	110	130	0	M8
	6	Q2E132M6B	Aluminum	279	475,5	2*M32	178	216	132	314	12	38	80	41	10	6208-2Z	6208-2Z	40*62*10	40*62*10	200	130	165	0	M10
	2	Q2E100L4D	Aluminum	217	352,0	1*M25	140	160	100	241	12	28	60	31	8	6306-2Z	6205-2Z	30*47*7	25*40*7	160	110	130	0	M8

DIMENSIONS - B14a, B34a

Power (kW)	Number of Poles	Motor Type	Housing Type	Main Dimensions			Foot Mounted Motors					Shaft				Bearing		Seal		Flange (FC) (B14a)				
				AC	L	O	B	A	H	HD	K	D ⁽¹⁾	E	GA	F ⁽²⁾	Drive Side	Non Drive Side	Drive Side	Non Drive Side	P	N ⁽³⁾	M	R	S
5,5	2	Q2E112M2CE	Aluminum	232	395,5	2*M25	140	190	112	261	12	28	60	31	8	6306-2Z	6206-2Z	30*47*7	30*47*7	160	110	130	0	M8
	4	Q2E112M4D	Aluminum	232	395,5	2*M25	140	190	112	261	12	28	60	31	8	6306-2Z	6206-2Z	30*47*7	30*47*7	160	110	130	0	M8
	2	Q2E132S2C	Aluminum	279	440,5	2*M32	140	216	132	314	12	38	80	41	10	6208-2Z	6208-2Z	40*62*10	40*62*10	200	130	165	0	M10
	4	Q2E132M4B	Aluminum	279	475,5	2*M32	140	216	132	314	12	38	80	41	10	6208-2Z	6208-2Z	40*62*10	40*62*10	200	130	165	0	M10
	6	Q2E132M6C	Aluminum	279	475,5	2*M32	178	216	132	314	12	38	80	41	10	6208-2Z	6208-2Z	40*62*10	40*62*10	200	130	165	0	M10
7,5	2	Q2E132M2A	Aluminum	279	475,5	2*M32	140	216	132	314	12	38	80	41	10	6208-2Z	6208-2Z	40*62*10	40*62*10	200	130	165	0	M10
	4	Q2E132M4C	Aluminum	279	475,5	2*M32	178	216	132	314	12	38	80	41	10	6208-2Z	6208-2Z	40*62*10	40*62*10	200	130	165	0	M10
11,0	2	Q2E132M2AE	Aluminum	279	475,5	2*M32	140	216	132	314	12	38	80	41	10	6208-2Z	6208-2Z	40*62*10	40*62*10	200	130	165	0	M10

(1) Tolerance DIN 50347 "j6" up to 28 mm "k6" above 28 mm

(2) According to DIN 6885

(3) Tolerance DIN EN 50347 "j6"

DIMENSIONS - B14b, B34b

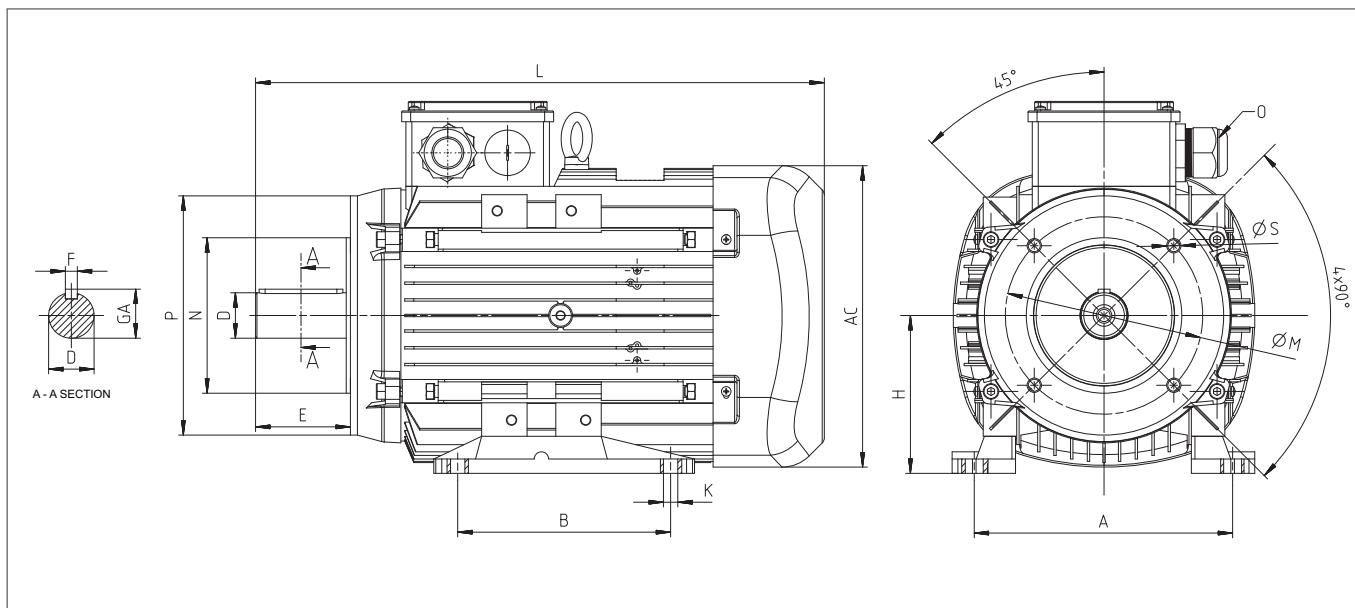

Power (kW)	Number of Poles	Motor Type	Housing Type	Main Dimensions			Foot Mounted Motors					Shaft			Bearing		Seal		Flange (FB) (B14b)					
				AC	L	O	B	A	H	HD	K	D ⁽¹⁾	E	GA	F ⁽²⁾	Drive Side	Non Drive Side	Drive Side	Non Drive Side	P	N ⁽³⁾	M	R	S
0,25	4	Q2E71M4B	Aluminum	138	252,5	1*M20	90	112	71	190	7	14	30	16	5	6202-2Z	6202-2Z	15*24*5	15*24*5	140	95	115	0	M8
	2	Q2E71M2C	Aluminum	138	252,5	1*M20	90	112	71	190	7	14	30	16	5	6202-2Z	6202-2Z	15*24*5	15*24*5	140	95	115	0	M8
0,37	4	Q2E71M4B	Aluminum	138	252,5	1*M20	90	112	71	190	7	14	30	16	5	6202-2Z	6202-2Z	15*24*5	15*24*5	140	95	115	0	M8
	2	Q2E71M2D	Aluminum	138	252,5	1*M20	90	112	71	190	7	14	30	16	5	6202-2Z	6202-2Z	15*24*5	15*24*5	140	95	115	0	M8
0,55	4	Q2E80M4B	Aluminum	158	283,5	1*M20	100	125	80	195	10	19	40	21,5	6	6204-2Z	6204-2Z	20*30*7	20*30*7	160	110	130	0	M8
	2	Q2E71M2DE	Aluminum	138	252,5	1*M20	90	112	71	190	7	14	30	16,0	5	6202-2Z	6202-2Z	15*24*5	15*24*5	140	95	115	0	M8
0,75	2	Q2E80M2B	Aluminum	158	283,5	1*M20	100	125	80	195	10	19	40	21,5	6	6204-2Z	6204-2Z	20*30*7	20*30*7	160	110	130	0	M8
	4	Q2E80M4D	Aluminum	158	283,5	1*M20	100	125	80	195	10	19	40	21,5	6	6204-2Z	6204-2Z	20*30*7	20*30*7	160	110	130	0	M8
1,1	2	Q2E90L6C	Aluminum	193	316,5	1*M25	100	140	90	222	10	24	50	27	8	6305-2Z	6205-2Z	25*40*7	25*40*7	160	110	130	0	M8
	6	Q2E80M2D	Aluminum	158	283,5	1*M20	100	125	80	195	10	19	40	21,5	6	6204-2Z	6204-2Z	20*30*7	20*30*7	160	110	130	0	M8
	4	Q2E80M4DE	Aluminum	158	283,5	1*M20	100	125	80	195	10	19	40	21,5	6	6204-2Z	6204-2Z	20*30*7	20*30*7	160	110	130	0	M8
	4	Q2E90L4C	Aluminum	193	316,5	1*M25	100	140	90	222	10	24	50	27	8	6305-2Z	6205-2Z	25*40*7	25*40*7	160	110	130	0	M8
1,5	6	Q2E90L6D	Aluminum	193	344,5	1*M25	125	140	90	222	10	24	50	27	8	6305-2Z	6205-2Z	25*40*7	25*40*7	160	110	130	0	M8
	2	Q2E80M2DE	Aluminum	158	283,5	1*M20	100	125	80	195	10	19	40	21,5	6	6204-2Z	6204-2Z	20*30*7	20*30*7	160	110	130	0	M8
	2	Q2E90L2C	Aluminum	193	316,5	1*M25	100	140	90	222	10	24	50	27	8	6305-2Z	6205-2Z	25*40*7	25*40*7	160	110	130	0	M8
	4	Q2E90L4D	Aluminum	193	316,5	1*M25	125	140	90	222	10	24	50	27	8	6305-2Z	6205-2Z	25*40*7	25*40*7	160	110	130	0	M8
2,2	6	Q2E100L6D	Aluminum	217	352,0	1*M25	140	160	100	241	12	28	60	31	8	6306-2Z	6205-2Z	30*47*7	25*40*7	200	130	165	0	M10
	2	Q2E90L2D	Aluminum	193	316,5	1*M25	125	140	90	222	10	24	50	27	8	6305-2Z	6205-2Z	25*40*7	25*40*7	160	110	130	0	M8
	4	Q2E90L4DE	Aluminum	193	344,5	1*M25	125	140	90	222	10	24	50	27	8	6305-2Z	6205-2Z	25*40*7	25*40*7	160	110	130	0	M8
	4	Q2E100L4C	Aluminum	217	352,0	1*M25	140	160	100	241	12	28	60	31	8	6306-2Z	6205-2Z	30*47*7	25*40*7	200	130	165	0	M10
3,0	6	Q2E112M6C	Aluminum	232	395,5	2*M25	140	190	112	261	12	28	60	31	8	6306-2Z	6206-2Z	30*47*7	30*47*7	200	130	165	0	M10
	2	Q2E90L2DE	Aluminum	193	316,5	1*M25	125	140	90	222	10	24	50	27	8	6305-2Z	6205-2Z	25*40*7	25*40*7	160	110	130	0	M8
	2	Q2E100L2C	Aluminum	217	352,0	1*M25	140	160	100	241	12	28	60	31	8	6306-2Z	6205-2Z	30*47*7	25*40*7	200	130	165	0	M10
	4	Q2E100L4D	Aluminum	217	352,0	1*M25	140	160	100	241	12	28	60	31	8	6306-2Z	6205-2Z	30*47*7	25*40*7	200	130	165	0	M10
4,0	6	Q2E132M6A	Aluminum	279	475,5	2*M32	140	216	132	314	12	38	80	41	10	6208-2Z	6208-2Z	40*62*10	40*62*10	250	180	215	0	M12 or 15
	2	Q2E100L2DE	Aluminum	217	352,0	1*M25	140	160	100	241	12	28	60	31	8	6306-2Z	6205-2Z	30*47*7	25*40*7	200	130	165	0	M10
	2	Q2E112M2C	Aluminum	232	395,5	2*M25	140	190	112	261	12	28	60	31	8	6306-2Z	6206-2Z	30*47*7	30*47*7	200	130	165	0	M10
	4	Q2E112M4C	Aluminum	232	395,5	2*M25	140	190	112	261	12	28	60	31	8	6306-2Z	6206-2Z	30*47*7	30*47*7	200	130	165	0	M10
4,0	6	Q2E132M6B	Aluminum	279	475,5	2*M32	178	216	132	314	12	38	80	41	10	6208-2Z	6208-2Z	40*62*10	40*62*10	250	180	215	0	M12 or 15

DIMENSIONS - B14b, B34b

Power (kW)	Number of Poles	Motor Type	Housing Type	Main Dimensions			Foot Mounted Motors					Shaft				Bearing		Seal		Flange (FB) (B14b)				
				AC	L	O	B	A	H	HD	K	D ⁽¹⁾	E	GA	F ⁽²⁾	Drive Side	Non Drive Side	Drive Side	Non Drive Side	P	N ⁽³⁾	M	R	S
5,5	2	Q2E112M2CE	Aluminum	232	395,5	2*M25	140	190	112	261	12	28	60	31	8	6306-2Z	6206-2Z	30*47*7	30*47*7	200	130	165	0	M10
	4	Q2E112M4D	Aluminum	232	395,5	2*M25	140	190	112	261	12	28	60	31	8	6306-2Z	6206-2Z	30*47*7	30*47*7	200	130	165	0	M10
	2	Q2E132S2C	Aluminum	279	440,5	2*M32	140	216	132	314	12	38	80	41	10	6208-2Z	6208-2Z	40*62*10	40*62*10	250	180	215	0	M12 or 15
	4	Q2E132M4B	Aluminum	279	475,5	2*M32	140	216	132	314	12	38	80	41	10	6208-2Z	6208-2Z	40*62*10	40*62*10	250	180	215	0	M12 or 15
	6	Q2E132M6C	Aluminum	279	475,5	2*M32	178	216	132	314	12	38	80	41	10	6208-2Z	6208-2Z	40*62*10	40*62*10	250	180	215	0	M12 or 15
7,5	2	Q2E132M2A	Aluminum	279	475,5	2*M32	140	216	132	314	12	38	80	41	10	6208-2Z	6208-2Z	40*62*10	40*62*10	250	180	215	0	M12 or 15
	4	Q2E132M4C	Aluminum	279	475,5	2*M32	178	216	132	314	12	38	80	41	10	6208-2Z	6208-2Z	40*62*10	40*62*10	250	180	215	0	M12 or 15
11,0	2	Q2E132M2AE	Aluminum	279	475,5	2*M32	140	216	132	314	12	38	80	41	10	6208-2Z	6208-2Z	40*62*10	40*62*10	250	180	215		M12 or 15

(1) Tolerance DIN EN 50347 "j6" up to 28 mm "k6" above 28 mm

(2) According to DIN 6885

(3) Tolerance DIN EN 50347 "j6"

THE MOTOR PART LIST WITH B3-B5-B14 FLANGE

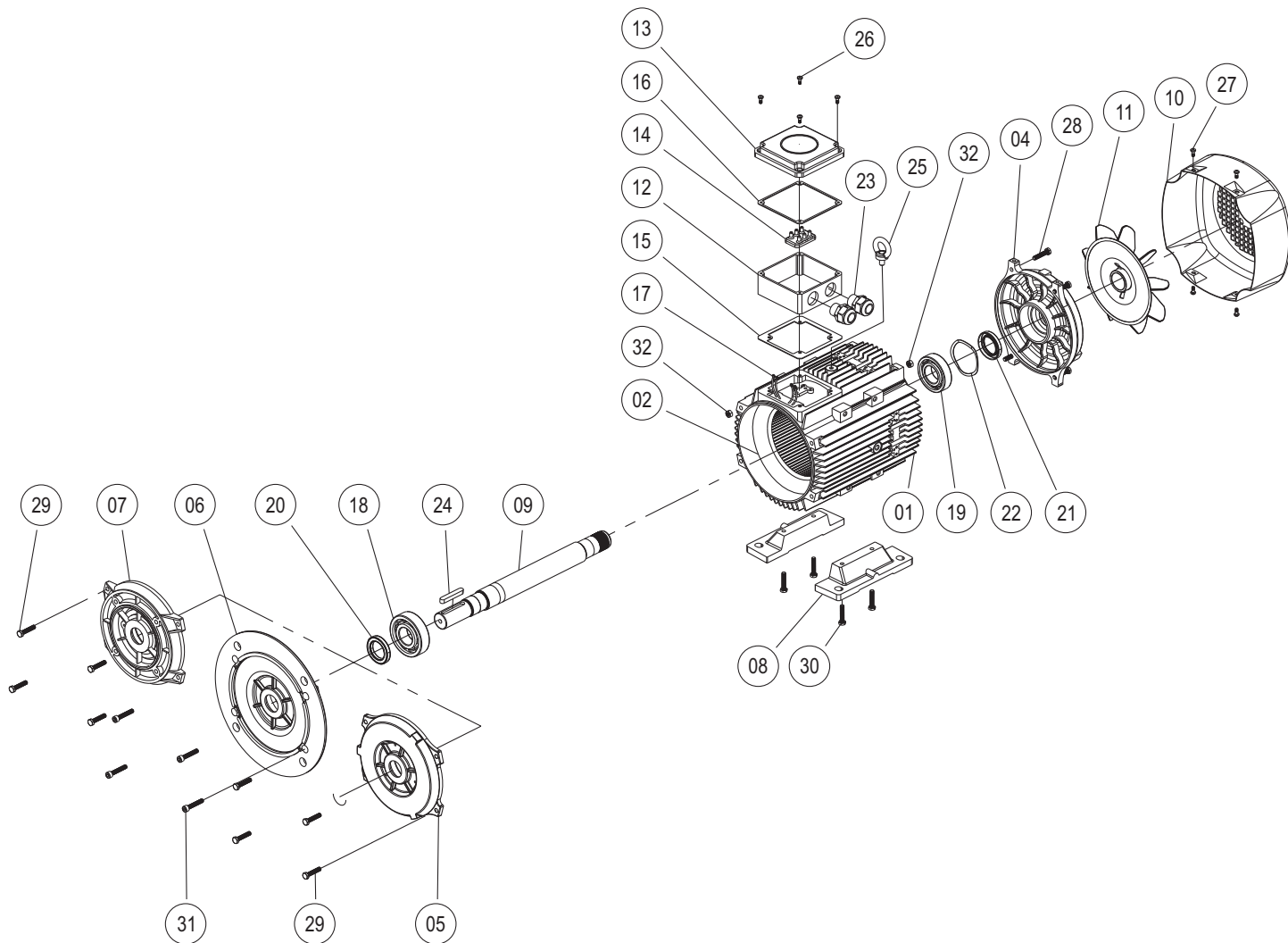

- | | | | |
|----|-----------------------|----|------------------------------|
| 01 | Housing | 17 | Lead Cables |
| 02 | Wound Stator | 18 | Bal Bearing (Drive-Side) |
| 03 | Rotor | 19 | Bal Bearing (Non-Drive-Side) |
| 04 | Nondrive - Endshield | 20 | Seal Ring (Front) |
| 05 | Flange | 21 | Seal Ring (Back) |
| 06 | Flange | 22 | Bearing Shim |
| 07 | Flange | 23 | Conduit |
| 08 | Foot | 24 | Key |
| 09 | Drive Shaft (Gearcut) | 25 | Eye Bolt |
| 10 | Fan Cover | 26 | Pan Head Secrews |
| 11 | Fan | 27 | Pan Head Secrews |
| 12 | Terminal Box | 28 | Bolt |
| 13 | Terminal Box Cover | 29 | Bolt |
| 14 | Terminal Plate | 30 | Bolt |
| 15 | Terminal Gasket Down | 31 | Bolt |
| 16 | Terminal Gasket Up | 32 | Nut |

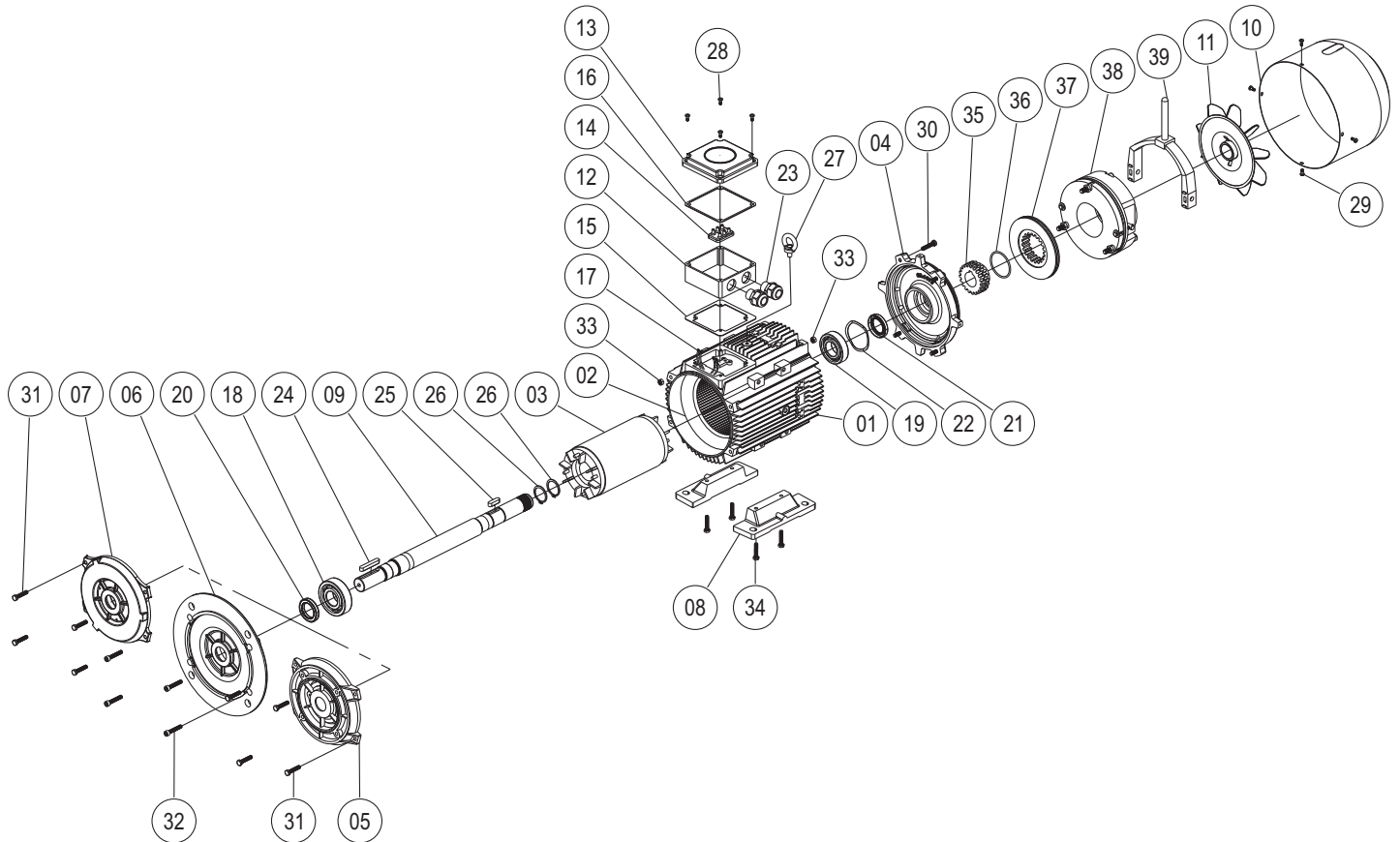
THE MOTOR PART LIST WITH BRAKE AND B3-B5-B14 FLANGE

01	Housing	21	Seal Ring (Back)
02	Wound Stator	22	Bearing Shim
03	Rotor	23	Conduit
04	Brake Connection Flange	24	Key
05	Flange	25	Key
06	Flange	26	Circilip DIN 471
07	Flange	27	Eye Bolt
08	Foot	28	Pan Head Secrews
09	Drive Shaft (Gearcut)	29	Pan Head Secrews
10	Fan Cover	30	Bolt
11	Fan	31	Bolt
12	Terminal Box	32	Bolt
13	Terminal Box Cover	33	Nut
14	Terminal Plate	34	Bolt
15	Terminal Gasket Down	35	Coupling
16	Terminal Gasket Up	36	O-Ring
17	Lead Cables	37	Brake Lining
18	Bal Bearing (Drive-Side)	38	Brake
19	Bal Bearing (Non-Drive-Side)	39	Hand Release
20	Seal Ring (Front)		

THE MOTOR PART LIST

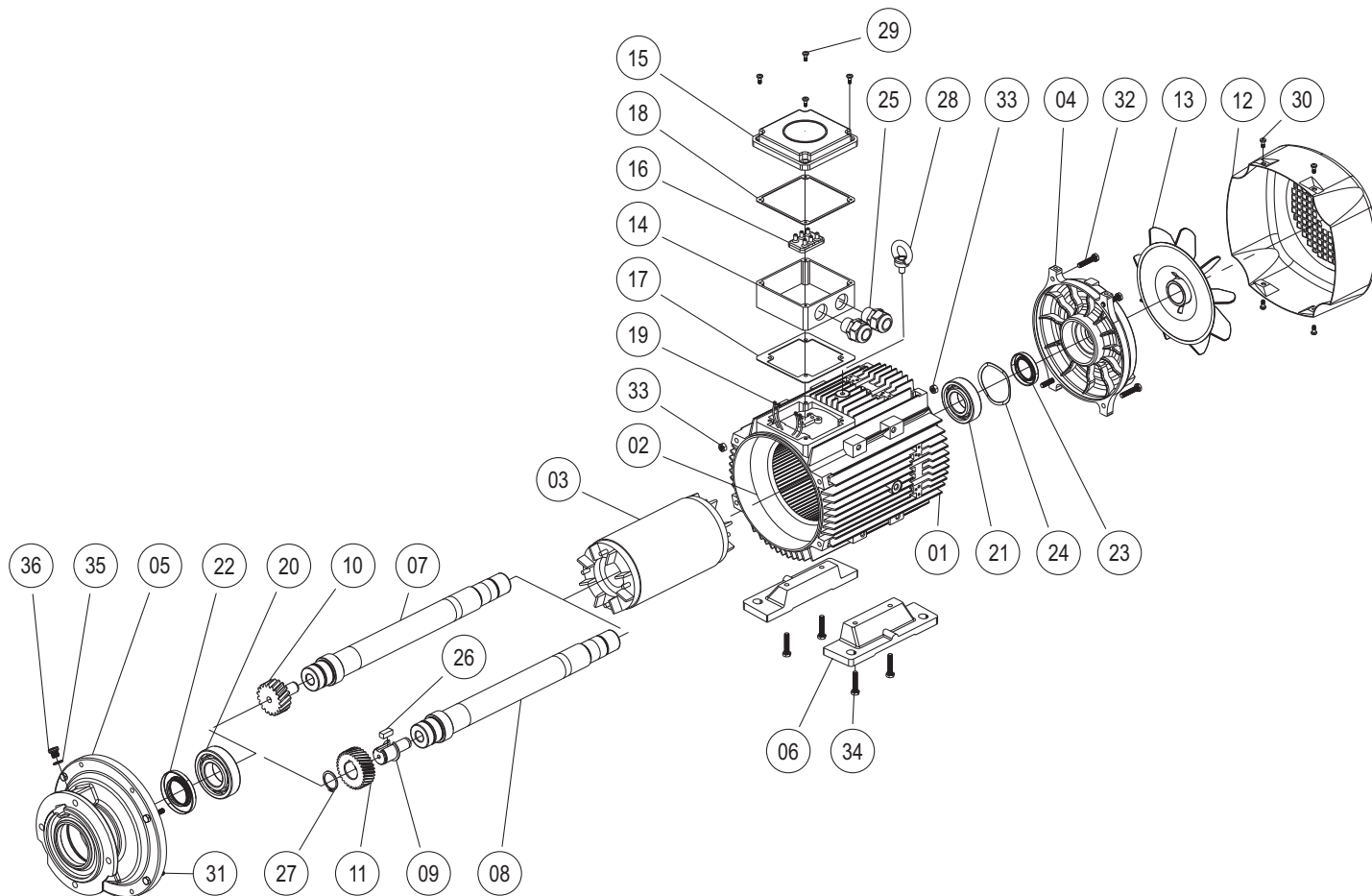

- | | | | |
|----|-------------------------|----|------------------------------|
| 01 | Housing | 19 | Lead Cables |
| 02 | Wound Stator | 20 | Bal Bearing (Drive-Side) |
| 03 | Rotor | 21 | Bal Bearing (Non-Drive-Side) |
| 04 | Nondrive - Endshield | 22 | Seal Ring (Front) |
| 05 | Moter Connection Flange | 23 | Seal Ring (Back) |
| 06 | Foot | 24 | Bearing Shim |
| 07 | Drive Shaft (Gearcut) | 25 | Conduit |
| 08 | Drive Shaft (Plain) | 26 | Key |
| 09 | Gear Shaft | 27 | Circilip DIN 471 |
| 10 | Z1 Gear | 28 | Eye Bolt |
| 11 | Z1 Gear | 29 | Pan Head Secrews |
| 12 | Fan Cover | 30 | Pan Head Secrews |
| 13 | Fan | 31 | Bolt |
| 14 | Terminal Box | 32 | Bolt |
| 15 | Terminal Box Cover | 33 | Nut |
| 16 | Terminal Plate | 34 | Bolt |
| 17 | Terminal Gasket Down | 35 | Washer |
| 18 | Terminal Gasket Up | 36 | Oil Plug |

THE MOTOR PART LIST WITH BRAKE

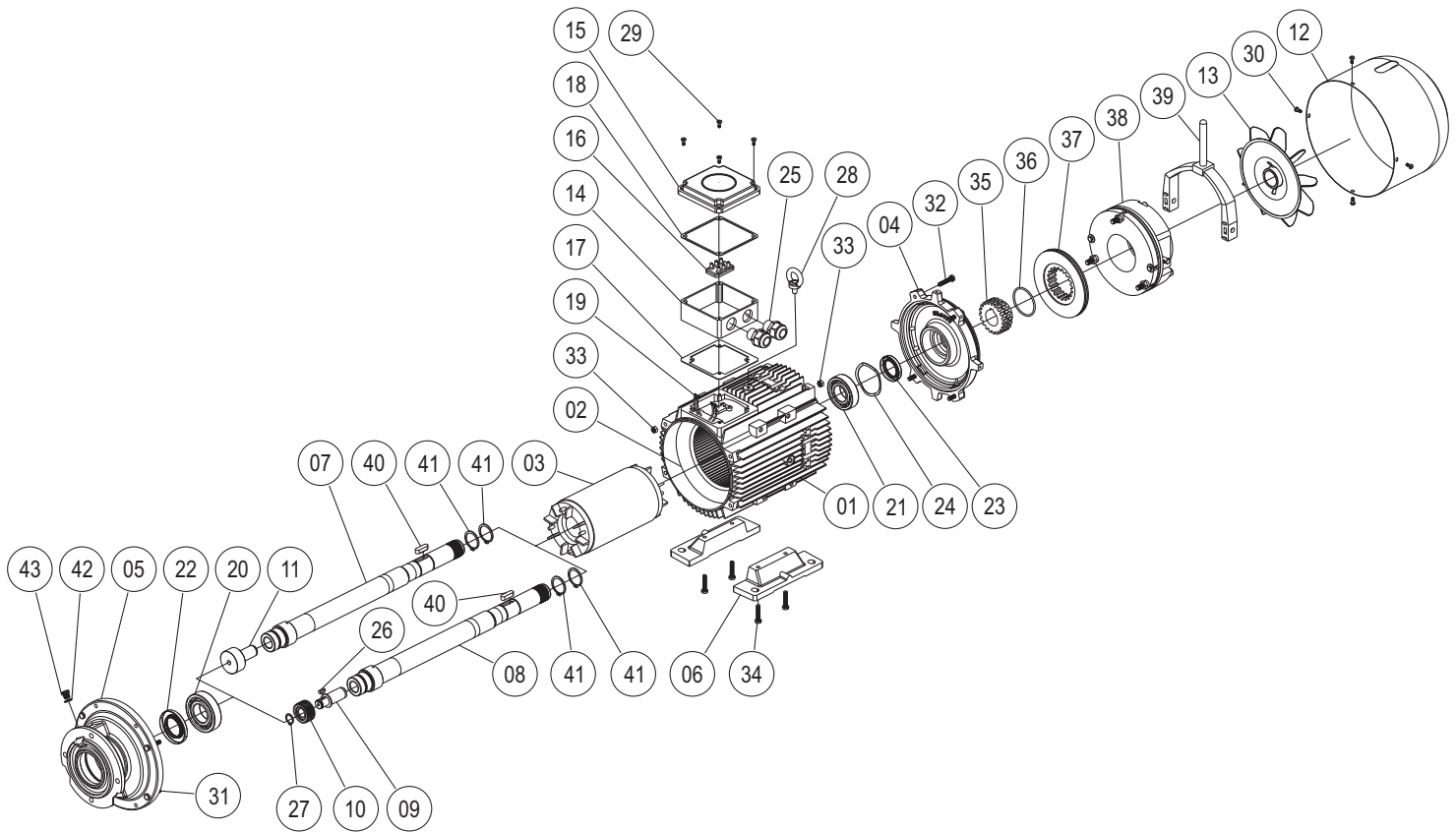

01	Housing	23	Seal Ring (Back)
02	Wound Stator	24	Bearing Shim
03	Rotor	25	Conduit
04	Brake Connection Flange	26	Key
05	Moter Connection Flange	27	Circilip DIN 471
06	Foot	28	Eye Bolt
07	Drive Shaft (Gearcut)	29	Pan Head Secrews
08	Drive Shaft (Plain)	30	Pan Head Secrews
09	Gear Shaft	31	Bolt
10	Z1 Gear	32	Bolt
11	Z1 Gear	33	Nut
12	Fan Cover	34	Bolt
13	Fan	35	Coupling
14	Terminal Box	36	O-Ring
15	Terminal Box Cover	37	Brake Lining
16	Terminal Plate	38	Brake
17	Terminal Gasket Down	39	Mond Release
18	Terminal Gasket Up	40	Key
19	Lead Cables	41	Circilip DIN 471
20	Bal Bearing (Drive-Side)	42	Washer
21	Bal Bearing (Non-Drive-Side)	43	Oil Plug
22	Seal Ring (Front)		

BRAKE PART LIST AND PROPERTIES

- 1 Electromagnet
- 2 Armature plate
- 3 Torque springs
- 4 Disc
- 5 Splined hub
- 6 O-ring
- 7 Adjuster rings
- 8 Adjuster nuts
- 9 Fixing screws

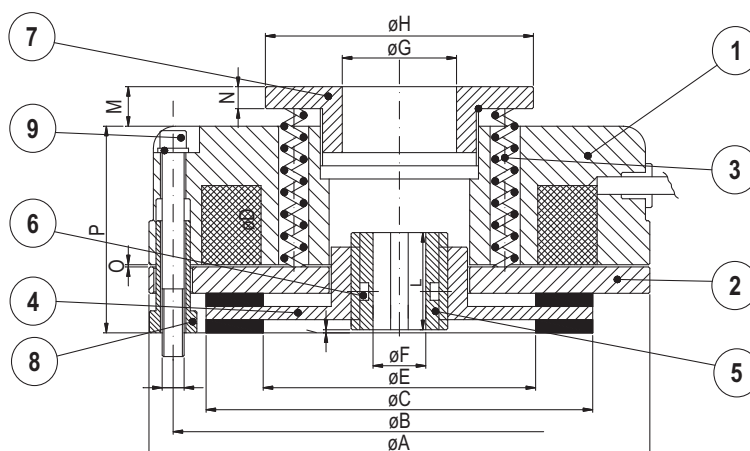

Type Brake Model		K1	K2	K3	K4	K5	K6	K7	K7/D	K8	K8/D	K9	K9/D	K9/T
Static Braking Torque	(Nm)	5	12	16	20	40	60	90	180	200	400	300	600	900
Max Speed of the motor	(rpm)	3000	3000	3000	3000	3000	3000	3000	3000	1500	1500	1500	1500	1500
Input Power	(W)	15	20	25	30	45	50	55	55	60	60	65	65	65
Max noisiness	(≤dB-A)	68	69	68	69	70	70	70	70	70	69	69	69	70
Weight	(Kg.)	1,1	1,85	2,55	2,84	4,8	7	12	15	14,3	18	23	28	34
	A	84	104	114	124	148	159	189	189	218	218	248	248	248
	B	72	90	103	112	132	145	170	170	196	196	230	230	230
	C	61	77	88	98	119	128	151	151	176	176	204	204	204
	D	3xM4	3xM5	3xM5	3xM6	3xM6	3xM8	3xM8	3xM8	6xM10	6xM10	6xM10	6xM10	9xM10
Tolerance hole till size K3 H7, others + 0,01/-0,01	E	35	44	62	69	79	80	90	90	103	103	132	132	132
	F	10-11 12	11-14 15	11-15	14-25	24-25 28	25-30 34	25-30 34	25 H40 34 H60	24-34	34 H60 48	44-45 48	44-45 48	44-45 48-50
	G	20	26	26	42	60	60	60	60	60	60	60	60	60
	H	50	61	61	79	104	104	104	104	104	104	104	104	104
	I	1,5	1,5	1,5	1,5	1,5	1,5	1,5	1,5	1,5	1,5	1,5	1,5	1,5
	L	18	20	20	20	25	30	30	60	40	60	40	60	80
	M (max)	9	9	9	9,5	18	16	14	14	18	18	18	18	18
	N	4	4	4	5,5	8	8	8	8	8	8	8	8	8
	O	0,2	0,2	0,2	0,2	0,3	0,3	0,3	0,3	0,3	0,4	0,4	0,4	0,4+0,5
	P	38,5	41,5	47	46,5	64	69,5	79	101,5	78	98	80	105	130

Note : The brake before running in, the static braking torque value could change by +20% from the reported value.



A large area of the page is filled with horizontal dotted lines, providing a template for writing or drawing.



In der Schlinge 6, D-59227 Ahlen / Germany

T: +49 (0) 2382-855 7010

F: +49 (0) 2382-855 7015

info@nrwdrivetechnologies.com

www.nrwdrivetechnologies.com | www.nrweurodrive.com | www.nrweurodrive.de

